

A DIE SETS



B PRECISION GROUND PLATES AND FLAT BARS



C LIFTING AND CLAMPING DEVICES



D GUIDE ELEMENTS



E GROUND PRECISION COMPONENTS



Punches and matrixes, Ball-Lock punches, retainers, pins, gauge pins



F SPRINGS



G ELASTOMERS



H FIBRO-CHEMICAL TOOLING AIDS



J PERIPHERAL EQUIPMENT



K CAM UNITS



L STANDARD PARTS FOR MOULD MAKING



GROUND PRECISION COMPONENTS



GROUND PRECISION COMPONENTS

FIBRO Precision Components cover a very wide range of materials, shapes and sizes and thus permit virtually unrestricted selection even to highly individual requirements.

At Hassmersheim and also abroad, stock levels of Precision Components reach seven-digit figures. It is therefore quite likely that your particular choice will be available for immediate delivery. Should this not be the case then our flexible batch production schedules will ensure that delays are kept to a minimum.

Batch production in our interpretation not only spells prompt delivery but also exceptional quality. Starting with the arrival inspection of raw materials, every single manufacturing operation on FIBRO Precision Components is followed by a quality check. Lastly, an uncompromising final inspection of each and every part guarantees that the trade mark FIBRO is and remains synonymous with Quality.

In view of the fact that a large portion of the Precision Components programme consists of punches and matrices, the importance of alignment in the operational die must be emphasized. Unless this requirement can be met to a high degree of accuracy, even the finest efforts in design and in the toolroom must fail!





Die alignment ultimately depends on the guides – FIBRO Die Sets and Guide Elements were developed and are made with this postulate in mind.

Tool life, production cost and work quality are to a large extent a function of tooling material selection versus strip stock characteristics and ancillary process conditions. A judicious choice from the wide range of materials for our punches and matrices will be facilitated by the orientation guide in this catalogue. Listing the principal characteristics of each material together with selection criteria, it is intended to help customers make the right choice.



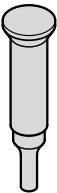
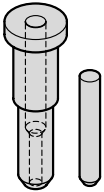
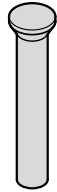
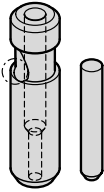
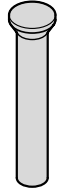
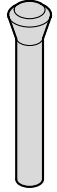
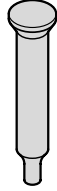
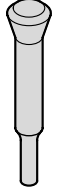
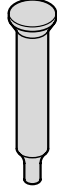
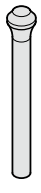
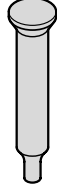

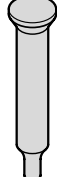





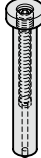

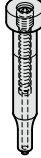
Our experienced tooling specialists will assist you with further detailed information.

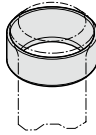
In keeping with the basic tenet of our firm, every effort is made to ensure that design, performance potential and quality of FIBRO Precision Components keep well abreast with latest technological developments.

CONTENTS

		E17				232.	E26
	Comparative graphs				Punch VDI 3374		
		E18-19				233.	E27
	Precision parts - material description				Insert sleeve with thrust pin VDI 3374 Shape A		
	222. Punch DIN 9861 Shape DA	E20			234. Insert sleeve with thrust pin VDI 3374 Shape B	E28	
	223. Punch DIN 9861 Shape D / ISO 6752	E21			2281. Punch with tapered head 30°, Shape D	E29	
	224. Punch DIN 9861 Shape CA	E22			2291. Punch with tapered head 30°, Shape C	E30	
	225. Punch DIN 9861 Shape C	E23			2284.3. Punch with tapered head, DIN 5118 Shape A	E31	
	274. Punch similar to DIN 9861 Shape CA	E24			2206. Punch with tapered head, blank, DIN 5118 Shape A	E32	
	275. Punch similar to DIN 9861 Shape C	E25			2216. Punch with tapered head, stepped, round, DIN 5118 Shape B	E33	

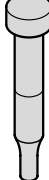
CONTENTS

	2706.	E34		267.	E42
	Punch with tapered head, blank, with ejector pin, DIN 5118 Shape E			Punch with ejector pin	
	2716.	E35		268.	E43
	Punch with tapered head, stepped, round, with ejector pin, DIN 5118 Shape F			Punch with ejector pin, stepped, short point	
	2284.00.	E36		269.	E44
	Piloted counterbore for tapered-head punch			Punch with ejector pin, stepped, long point	
	2284.00.01.	E37		270.	E47
	Mounting ring for punch with tapered head			Punch similar to DIN 9844, Shape A	
		E38		271.	E48
	Punch - installation guidelines			Punch similar to DIN 9844, Shape B	
	220.	E39		272.	E49
	Punch DIN 9844, Shape A			Punch similar to DIN 9861, Shape D	
	221.	E40		273.	E50
	Punch DIN 9844, Shape B			Punch similar to DIN 9861, Shape C	
	266.	E41		2202.	E53
	Punch similar to VDI 3374			Ball-Lock punch, blank, light duty	

CONTENTS

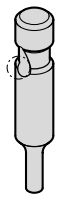

2212. **E54**

Ball-Lock punch, stepped, round, light duty

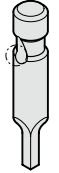

2222. **E55**

Ball-Lock punch, stepped, square, light duty

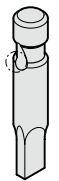

2232. **E56**

Ball-Lock punch, stepped, rectangular, light duty

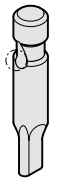

2242. **E57**

Ball-Lock punch, stepped, slot, light duty

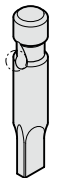

2252. **E58**

Ball-Lock punch, stepped, rectangle with radiussed corners, light duty

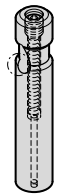

2702. **E59**

Ball-Lock punch, blank, with ejector pin, light duty

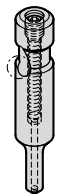

2712. **E60**

Ball-Lock punch, stepped, round, with ejector pin, light duty

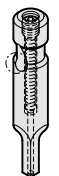

2722. **E61**

Ball-Lock punch, stepped, square, with ejector pin, light duty

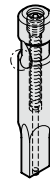

2732. **E62**

Ball-Lock punch, stepped, rectangular, with ejector pin, light duty

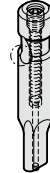

2742. **E63**

Ball-Lock punch, stepped, slot, with ejector pin, light duty

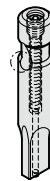

2752. **E64**

Ball-Lock punch, stepped, rectangle with radiussed corners, with ejector pin, light duty

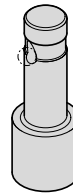

2204. **E65**

Ball-Lock punch, punch larger than shaft, blank, light duty

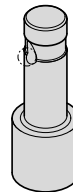

2214. **E66**

Ball-Lock punch, punch larger than shaft, round, light duty

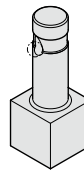

2224. **E67**

Ball-Lock punch, punch larger than shaft, square, light duty



2234. **E68**

Ball-Lock punch, punch larger than shaft, rectangular, light duty



2244. **E69**

Ball-Lock punch, punch larger than shaft, slot, light duty

CONTENTS

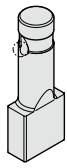

2254. **E70**

Ball-Lock punch, punch larger than shaft, rectangle with radiussed corners, light duty

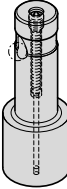

2704. **E71**

Ball-Lock punch, punch larger than shaft, blank, with ejector pin, light duty

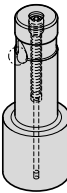

2714. **E72**

Ball-Lock punch, punch larger than shaft, round, with ejector pin, light duty

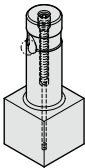

2724. **E73**

Ball-Lock punch, punch larger than shaft, square, with ejector pin, light duty

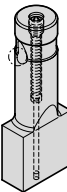

2734. **E74**

Ball-Lock punch, punch larger than shaft, rectangular, with ejector pin, light duty

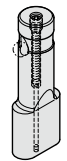

2744. **E75**

Ball-Lock punch, punch larger than shaft, slot, with ejector pin, light duty

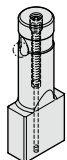

2754. **E76**

Ball-Lock punch, punch larger than shaft, rectangle with radiussed corners, with ejector pin, light duty

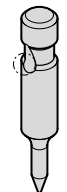

2262. **E77**

Ball-Lock pilot pin, with tapered tip, light duty



2272. **E78**

Ball-Lock pilot pin, with parabolic tip, light duty



2203. **E79**

Ball-Lock punch, blank, heavy duty



2213. **E80**

Ball-Lock punch, stepped, round, heavy duty

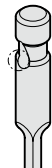

2223. **E81**

Ball-Lock punch, stepped, square, heavy duty

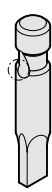

2233. **E82**

Ball-Lock punch, stepped, rectangular, heavy duty

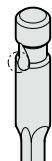

2243. **E83**

Ball-Lock punch, stepped, slot, heavy duty



2253. **E84**



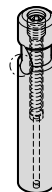



Ball-Lock punch, stepped, rectangle with radiussed corners, heavy duty

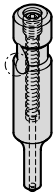
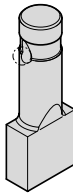

2703. **E85**

Ball-Lock punch, blank, with ejector pin, heavy duty

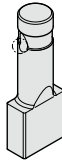
CONTENTS

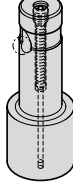
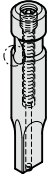
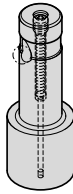
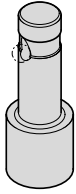
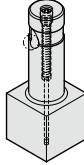
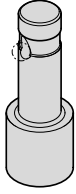
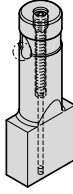
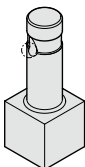
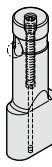
	2713. Ball-Lock punch, stepped, round, with ejector pin, heavy duty	E86		2235. Ball-Lock punch, punch larger than shaft, rectangular, heavy duty	E94
	2723. Ball-Lock punch, stepped, square, with ejector pin, heavy duty	E87		2245. Ball-Lock punch, punch larger than shaft, slot, heavy duty	E95
	2733. Ball-Lock punch, stepped, rectangular, with ejector pin, heavy duty	E88		2255. Ball-Lock punch, punch larger than shaft, rectangle with radiussed corners, heavy duty	E96
	2743. Ball-Lock punch, stepped, slot, with ejector pin, heavy duty	E89		2705. Ball-Lock punch, punch larger than shaft, blank, with ejector pin, heavy duty	E97
	2753. Ball-Lock punch, stepped, rectangle with radiussed corners, with ejector pin, heavy duty	E90		2715. Ball-Lock punch, punch larger than shaft, round, with ejector pin, heavy duty	E98
	2205. Ball-Lock punch, punch larger than shaft, blank, heavy duty	E91		2725. Ball-Lock punch, punch larger than shaft, square, with ejector pin, heavy duty	E99
	2215. Ball-Lock punch, punch larger than shaft, round, heavy duty	E92		2735. Ball-Lock punch, punch larger than shaft, rectangular, with ejector pin, heavy duty	E100
	2225. Ball-Lock punch, punch larger than shaft, square, heavy duty	E93		2745. Ball-Lock punch, punch larger than shaft, slot, with ejector pin, heavy duty	E101

CONTENTS

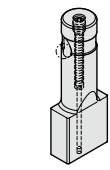

2755. **E102**

Ball-Lock punch, punch larger than shaft, rectangle with radiussed corners, with ejector pin, heavy duty

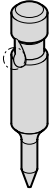

2263. **E103**

Ball-Lock pilot pin, with tapered tip, heavy duty

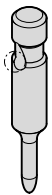

2273. **E104**

Ball-Lock pilot pin, with parabolic tip, heavy duty

E109

BOLT LOCK punches - special designs

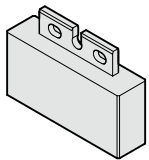

2207. **E110**

Punch BOLT LOCK, blank

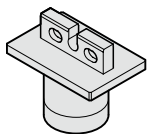

2217. **E111**

Punch BOLT LOCK, round

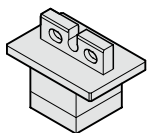

2227. **E112**

Punch BOLT LOCK, square

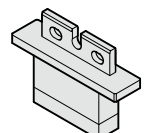

2237. **E113**

Punch BOLT LOCK, rectangular

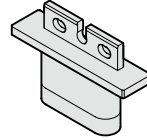

2247. **E114**

Punch BOLT LOCK, slot

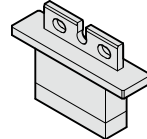

2257. **E115**

Punch BOLT LOCK, rectangle with radiussed corners



2201. **E119**

Punch, blank, ISO 8020



2211. **E120**

Punch, stepped, round, ISO 8020



2221. **E121**

Punch, stepped, square, ISO 8020



2231. **E122**

Punch, stepped, rectangular, ISO 8020



2241. **E123**

Punch, stepped, slot, ISO 8020



2251. **E124**

Punch, stepped, rectangle with radiused corners, ISO 8020

CONTENTS

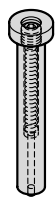

2701. **E125**

Punch, blank, with ejector pin, ISO 8020

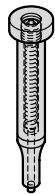

2711. **E126**

Punch, stepped, round, with ejector pin, ISO 8020

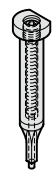

2721. **E127**

Punch, stepped, square, with ejector pin, ISO 8020

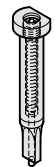

2731. **E128**

Punch, stepped, rectangular, with ejector pin, ISO 8020

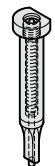

2741. **E129**

Punch, stepped, slot, with ejector pin, ISO 8020

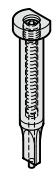

2751. **E130**

Punch, stepped, rectangle with radiussed corners, with ejector pin, ISO 8020

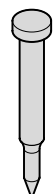

2261. **E131**

Pilot pin with tapered tip, ISO 8020

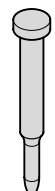

2271. **E132**

Pilot pin with parabolic tip, ISO 8020



2276. **E133**

Pilot unit to Mercedes-Benz Standard

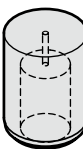

2606. **E137**

Matrix without shoulder, blank, ISO 8977

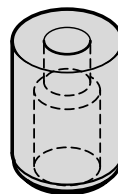

2616. **E138**

Matrix without shoulder, round, ISO 8977

Rotation locks **E139-147, E151-159, E163-171**

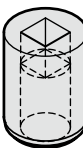

2626. **E140**

Matrix without shoulder, square, ISO 8977

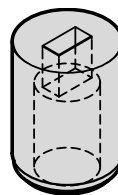

2636. **E142**

Matrix without shoulder, rectangular, ISO 8977

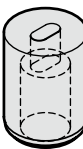

2646. **E144**

Matrix without shoulder, slot, ISO 8977

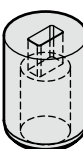

2656. **E146**

Matrix without shoulder, rectangle with radiussed corners, ISO 8977

CONTENTS

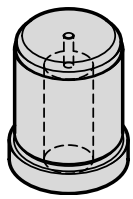

2607. **E149**

Matrix with shoulder, blank, ISO 8977

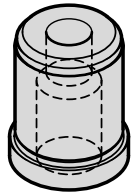

2617. **E150**

Matrix with shoulder, round, ISO 8977



2627. **E152**

Matrix with shoulder, square, ISO 8977

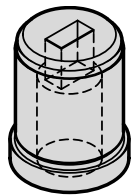

2637. **E154**

Matrix with shoulder, rectangular, ISO 8977

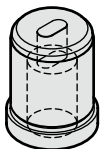

2647. **E156**

Matrix with shoulder, slot, ISO 8977

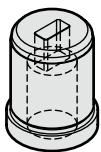

2657. **E158**

Matrix with shoulder, rectangle with radiussed corners, ISO 8977

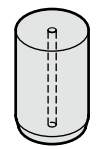

2605. **E160**

Matrix without shoulder, blank, Automotive Standard

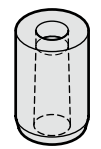

2615. **E162**

Matrix without shoulder, round, Automotive Standard



2625. **E164**

Matrix without shoulder, square, Automotive Standard

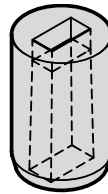

2635. **E166**

Matrix without shoulder, rectangular, Automotive Standard

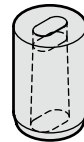

2645. **E168**

Matrix without shoulder, slot, Automotive Standard

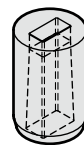

2655. **E170**

Matrix without shoulder, rectangle with radiussed corners, Automotive Standard

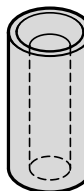

262. **E172**

Guide bush for punch, DIN 9845 Shape C

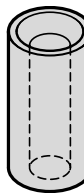

2621. **E173**

Guide bush for punch, ISO 8978

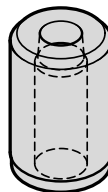

260. **E174**

Matrix without collar, DIN 9845 Shape A

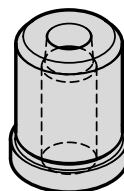

261. **E175**

Matrix with collar, DIN 9845 Shape B

CONTENTS

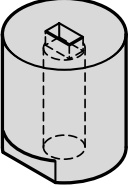
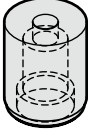
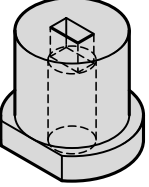
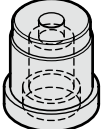
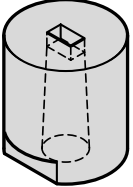
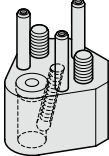
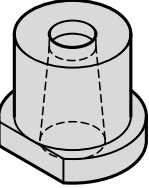
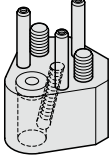
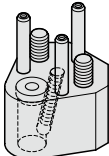
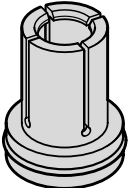
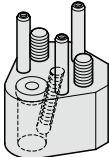
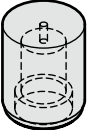
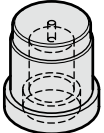
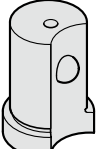
	2602. Matrix without collar, cylindrical	E176		2618.16. Matrix without collar for dynamic stripper (DAE), round	E191
	2612. Matrix with collar, cylindrical	E177		2618.17. Matrix with collar for dynamic stripper (DAE), round	E192
	2601. Matrix without collar, conical	E178		2664.05. Triangle retainer for ball-lock punches, light duty	E194
	2611. Matrix with collar, conical	E179		2664.06. Triangle retainer for ball-lock punches, heavy duty	E195
	Standardised special shapes	E183, E185		2664.07. Triangle retainer for ball-lock punches, light duty	E196
	2618. Dynamic stripping element (DAE)	E186-187		2664.10. Triangle retainer for ball-lock punches, heavy duty	E197
	2618.06. Matrix without collar for dynamic stripper (DAE), blank	E189		Accessories for retainers, triangular, for Ball-Lock punches	E198
	2618.07. Matrix with collar for dynamic stripper (DAE), blank	E190		2668.2. ACCU-LOCK Fixture device for ball-lock punches, light duty	E199

CONTENTS

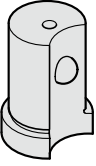
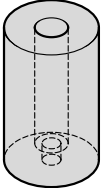
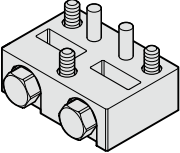
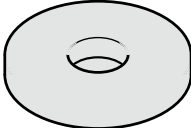
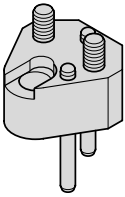
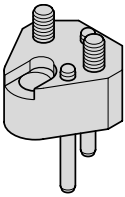
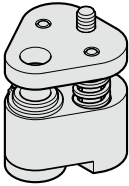
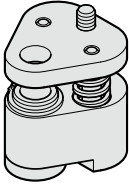
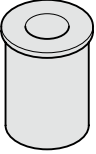
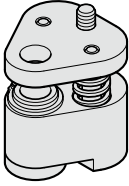
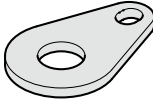
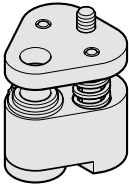
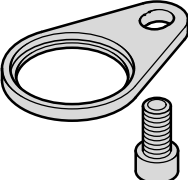
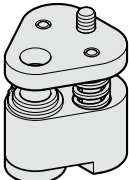
	2668.3. ACCU-LOCK Fixture device for ball-lock punches, heavy duty	E200		243.7. Elastomer Stripper	E214
	2664.11. Retainer BOLT LOCK	E202-204		243.7. .1 Washer	E215
	2664.02. Triangle retainer, for punches ISO 8020 without anti-rotation element	E206		POLY STRIP stripper unit - Order examples	E216
	2664.04. Triangle retainer, for punches ISO 8020 with anti-rotation element	E207		2667.iso.0. POLY STRIP stripper unit, with start borehole, for ISO 8020 punch	E217
	E208 Accessories for retainers, triangular, for punches to ISO 8020			2667.iso.1. POLY STRIP stripper unit, round, for ISO 8020 punch	E218
	2431.7. Elastomer Stripper	E210		2667.iso.2. POLY STRIP stripper unit, square, for ISO 8020 punch	E219
	2667.1. Stripping unit - Pressure plate	E211		2667.iso.3. POLY STRIP stripper unit, rectangle, for ISO 8020 punch	E220
	2667.2. Stripping unit - Mounting plate	E212		2667.iso.4. POLY STRIP stripper unit, slot, for ISO 8020 punch	E221

CONTENTS

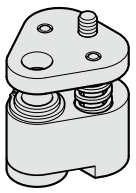

2667.iso.5. **E222**

POLY STRIP stripper unit, rectangle with radius, for ISO 8020 punch

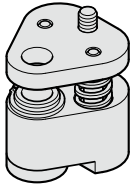

2667.sw.0. **E223**

POLY STRIP stripper unit, with start borehole, for ball-lock punch

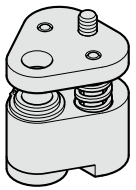

2667.sw.1. **E224**

POLY STRIP stripper unit, round, for ball-lock punch

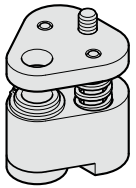

2667.sw.2. **E225**

POLY STRIP stripper unit, square, for ball-lock punch

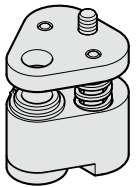

2667.sw.3. **E226**

POLY STRIP stripper unit, rectangle, for ball-lock punch

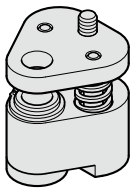

2667.sw.4. **E227**

POLY STRIP stripper unit, slot, for ball-lock punch

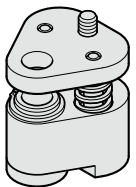

2667.sw.5. **E228**

POLY STRIP stripper unit, square with radius, for ball-lock punch

E230-231

Special punches and matrixes to customer's drawings

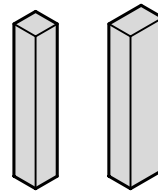

230. **E232**

Punch without head, square / rectangular, Shape A

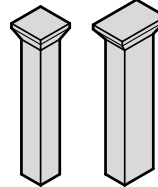

231. **E233**

Punch with head, square / rectangular, Shape B



236.1. **E234**

Dowel pin with internal extracting thread, similar to DIN EN ISO 8735



2361.1. **E235**

Dowel pin with internal extracting thread, according to DIN EN ISO 8735

236.001 **E236**

FIBROZIPP



265.1. **E238**

Liner bush for dowel pin, for bonding

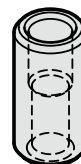

2650.1. **E239**

Liner bush for dowel pin, for push fit



235.1. **E240**

Dowel pin similar to DIN EN ISO 8734

CONTENTS



2351.1.

E241

Dowel pin according to
DIN EN ISO 8734

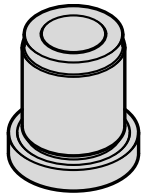

276.

E242

Drill bush with collar,
DIN 172 Shape A

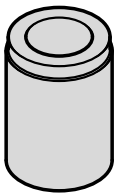

277.

E243

Drill bush without collar,
DIN 179 Shape A



240.1./2.

E244

Gauge pin DIN 2269

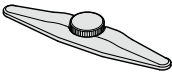

240.45.

E246

Gauge Pin Holders

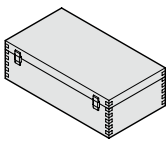

240.9x.

E246

Wooden boxes

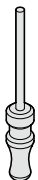

240.11./22.

E247

Gauge pin with handle, DIN 2269

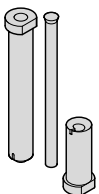

2282.01.

E248

Punching and embossing unit with
matrix for punched holes and self
tapping screws

COMPARATIVE GRAPHS

Compressive strength (0,2 proof stress)

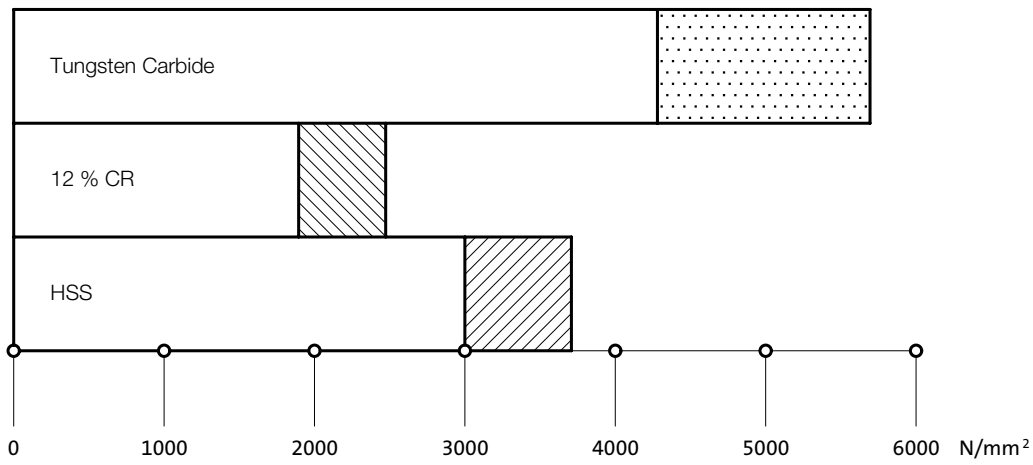

Flexural strength

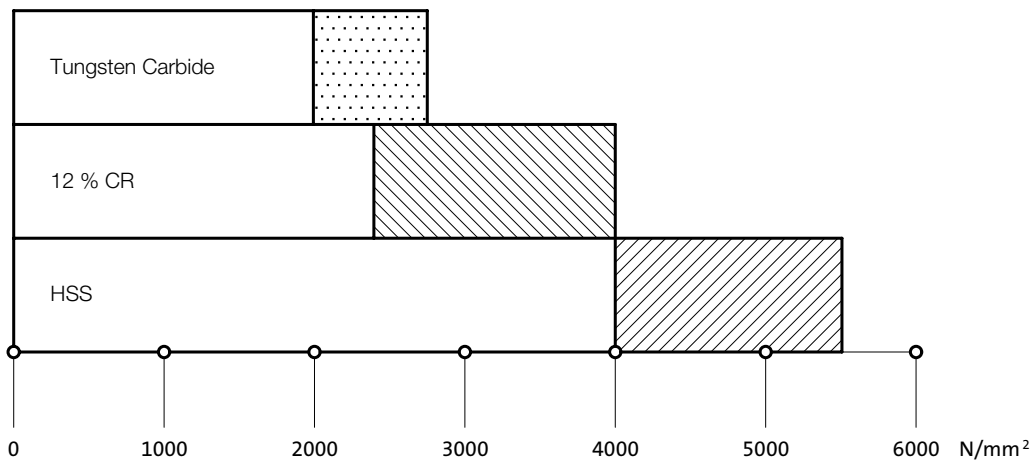

Hardness Vickers

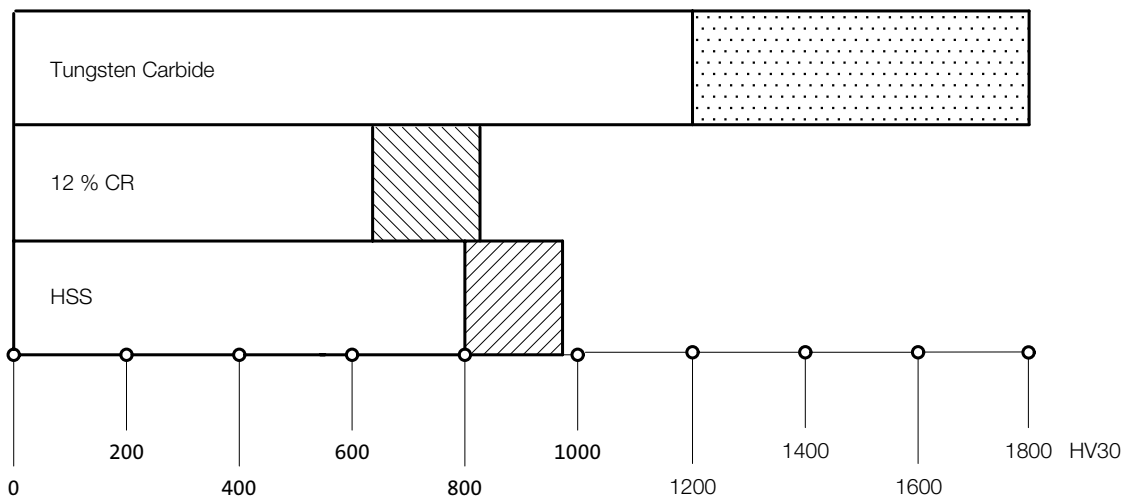

PRECISION PARTS - MATERIAL DESCRIPTION

WS	=	alloyed tool steel
Characteristics:		Material No 1.2210, 1.2516, 1.2842 or similar.
Application area:		Hard and tough tool steel, medium wear resistance. Piercing/blanking dies for mild steel, low carbon steels, non-ferrous metals, plastics, paper.
		WS = material code = "1"
		e.g. Order no. = 239.1. ...
HWS	=	High Carbon – High Chrome Tool Steel (12% Cr)
Characteristics:		Material No 1.2436, 1.2379 or similar.
Application area:		High resistance to wear. Piercing/blanking dies of all types, trim dies, for all carbon steels, alloy steels, non-ferrous metals, plastics, paper.
		HWS = material code = "2"
		e.g. Order no. = 260.2. ...
HSS	=	High Speed Steel
Characteristics:		Material No 1.3343 or similar.
Application area:		High resistance to wear. Piercing/blanking dies of all types – for tough materials e.g. spring steel, lamination steels, and abrasive papers as well as plastic.
		HSS = material code = "3"
		e.g. Order no. = 220.3. ...
ASP 23	=	High Speed Steel on Powder-Metallurgic Basis
ASP 2023		
Characteristics:		High resistance to wear. Greater strength than HSS due to excellent homogeneity of the material.
Application area:		Same as HSS.
		ASP 23
		ASP 2023= material code = "6"
		e.g. Order no. = 223.6. ...
HST	=	High Speed Steel, Nitrided
Characteristics:		High wear-resistance, reduced tendency for cold welding. The nitrogen nitrides diffused in during the nitriding treatment give the tool part even greater wear resistance and the best possible protection against cold welding.
Application area:		Piercing/blanking dies of all types – for very hard and abrasive materials.
		HST = material code = "4"
		e.g. Order no. = 223.4. ...

PRECISION PARTS - MATERIAL DESCRIPTION

HZ	=	Hard-coated Tooling Components for High-Performance
Carrier materials:		HZC Composite Vapour Deposition (CVD) TIC-TIN Coating High-speed steels Material no. 1.3207, 1.3343, etc. Cold steels Material no. 1.2379, 1.2436, etc. Due to the risk of distortion, a coating should not be applied to thin tools with a streamlined size of $l/d = 20:1$. In addition, we cannot accept any liability for distortion for any other parts.
Characteristics:		The titanium carbide substrate provides a pressure-resistant bond with the carrier metal, while the outer layer of titanium nitride offers the well-known advantages of optimum tribologic behaviour in contact with the stamping stock. By virtue of its outstanding wear resistance, the TIN-layer largely eliminates seizing and cold welding problems in stamping. Surface hardness approx. 3500 HV 0.05 Layer thickness approx. 5 - 8 μm .
Application area:		All tooling components subject to high demands on wear resistance and performance, especially punches in progression/combination tools, as well as cold extrusion punches etc. TIC-TIN = material code number = "5" e.g. Order no. = 223.5. ... HZN PVD titanium nitride TIN
Carrier materials:		The TIN-coating offers excellent frictional characteristics but its compressive strength remains inferior to TIC-TIN deposits. Option for partial coating. Surface hardness approx. 2300 HV 0.05 Layer thickness 2 - 4 μm ; $< \varnothing 2.0 = 1.5 \mu\text{m} \pm 20 \%$ HSS Material No 1.3207 and 1.3343 etc. HCHC Material No 1.2379
Characteristics:		Other HCHC-steels are of conditional suitability. The TIN-coating offers excellent frictional characteristics but its compressive strength remains inferior to TIC-TIN deposits. Option for partial coating. Surface hardness approx. 2300 HV 0.05 Layer thickness 2 - 4 μm ; $< \varnothing 2.0 = 1.5 \mu\text{m} \pm 20 \%$
Application area:		Tooling for thin stamping stock such as cold rolled spring steel, zinc-galvanized sheet and strip, copper-beryllium bronze, German silver, and solenoid lamination steels. Note that the ratio stock thickness to punch point diameter should not exceed 1:3. TIN = material code number = "0" e.g. Order no. = 223.0. ...
HM	=	Tungsten Carbide
Characteristics:		Hard-sintered carbide on WC-basis and of recognized properties; produced by powder-metallurgic processes, FIBRO's exclusively used HIP-densified carbide exhibits much enhanced flexural strength and reduced residual porosity.
Application area:		Die components for highest performance and very large stamping volumes – for altogether ultimate demands on tool life. HM = material code = "9" e.g. Order no. = 270.9. ...
NWA	=	Nitrided hot-work tool steel
Characteristics:		Material No 1.2344 or similar. Chrome-Molybdenum-Vanadium hot working die steel; core strength: $> 1400 \text{ N/mm}^2$; temperature resistant up to $650 \text{ }^\circ\text{C}$; surface hardness (nitrided) $\geq 950 \text{ HV } 0.3$.
Application area:		Ejector for die casting and injection moulds. NWA = material code number = "8" e.g. Order no. = 237.8. ...

PUNCH DIN 9861 SHAPE DA



222.

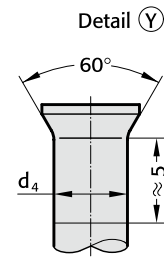
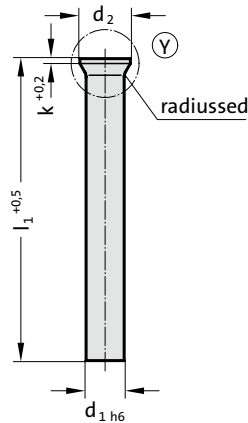

222. Punch DIN 9861 Shape DA

Gradation		d ₂	k	l ₁	71	80	100
d ₁	d ₁						
0,5	0,05	0,9	0,2		●	●	●
0,55	0,05	1	0,2		●	●	●
0,6	0,05	1,1	0,2		●	●	●
0,65	0,05	1,2	0,2		●	●	●
0,7	0,05	1,3	0,2		●	●	●
0,8	0,05	1,4	0,4		●	●	●
0,9	0,05	1,6	0,4		●	●	●
1	0,1	1,8	0,5		●	●	●
1,2	0,1	2	0,5		●	●	●
1,4	0,1	2,2	0,5		●	●	●
1,6	0,1	2,5	0,5		●	●	●
1,8	0,1	2,8	0,5		●	●	●
2	0,1	3	0,5		●	●	●
2,1	0,1	3,2	0,5		●	●	●
2,3	0,1	3,5	0,5		●	●	●
2,6	0,1	4	0,5		●	●	●
3	0,1	4,5	0,5		●	●	●
3,5	0,1	5	0,5		●	●	●
4	0,1	5,5	0,5		●	●	●
4,5	0,1	6	0,5		●	●	●
5	0,1	6,5	0,5		●	●	●
5,5	0,1	7	0,5		●	●	●
6	0,1	8	0,5		●	●	●
6,5	0,5	9	1		●	●	●
7,5	0,5	10	1		●	●	●
8,5	0,5	11	1		●	●	●
9,5	0,5	12	1		●	●	●
10,5	0,5	13	1		●	●	●
11,5	0,5	14	1		●	●	●
12,5	0,5	15	1		●	●	●
13,5	0,5	16	1,5		●	●	●
14,5	0,5	17	1,5		●	●	●
15,5	0,5	18	1,5		●	●	●

Material:

HSS
 Order No 222.3.
 Hardness:
 Shaft 64 ± 2 HRC
 Head 52 ± 3 HRC

HST
 Order No 222.4.
 Hardness:
 Surface ≥ 950 HV 0,3
 Head 52 ± 3 HRC

HZ - TIN (HSS)
 Order No 222.0.
 Hardness:
 Surface 2300 HV 0,05
 Head 52 ± 3 HRC

☞ Description of FIBRO materials for tool and die components see at the beginning of Chapter E.

Execution:

Shaft precision ground. Head hot upset-forged and tempered. Residual upset bulge below head normally much smaller than permissible acc. to DIN 9861.

d₄: For d₁ < 1 mm, d₄=d₁ + 0,02
 For d₁ ≥ 1 mm, d₄=d₁ + 0,03

Stock lengths: 71, 80, 100 mm.
 other lengths and diameters on request!

Note:

Punches are also available without head

Ordering Code (example):

Punch DIN 9861 Shape DA	=	222.
Material MAT	HSS	= 3.
Shaft diameter d ₁	3 mm	= 0300.
Length l ₁	71 mm	= 071
Order No		= 222.3.0300.071

PUNCH DIN 9861 SHAPE D / ISO 6752

223.

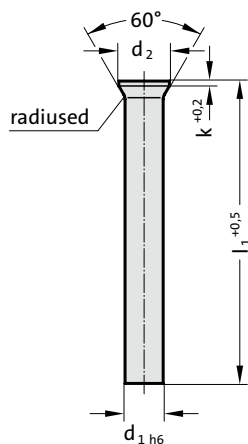

Material:

HSS
 Order No 223.3.
 Hardness:
 Shaft 64 ± 2 HRC
 Head 52 ± 3 HRC

HST
 Order No 223.4.
 Hardness:
 Surface ≥ 950 HV 0,3
 Head 52 ± 3 HRC

HZ - TIN (HSS)
 Order No 223.0.
 Hardness:
 Surface 2300 HV 0,05
 Head 52 ± 3 HRC

ASP 23 - ASP 2023
 Order No 223.6.
 Hardness:
 Shaft 64 ± 2 HRC
 Head 52 ± 3 HRC

Description of FIBRO materials for tool and die components see at the beginning of Chapter E.

Execution:

Head hot upset-forged and tempered. Shaft and head subsequently precision plunge-ground for perfect concentricity and full interchangeability with replacement punches.

Stock lengths: 71, 80, 100 mm.
 other lengths and diameters on request!

223. Punch DIN 9861 Shape D / ISO 6752

d ₁	Gradation			71	80	100
	d ₁	d ₂	k			
0,5	0.05	0.9	0.2	●	●	●
0,55	0.05	1	0.2	●	●	●
0,6	0.05	1.1	0.2	●	●	●
0,65	0.05	1.2	0.2	●	●	●
0,7	0.05	1.3	0.2	●	●	●
0,8	0.05	1.4	0.4	●	●	●
0,9	0.05	1.6	0.4	●	●	●
1	0.1	1.8	0.5	●	●	●
1,2	0.1	2	0.5	●	●	●
1,4	0.1	2.2	0.5	●	●	●
1,6	0.1	2.5	0.5	●	●	●
1,8	0.1	2.8	0.5	●	●	●
2	0.1	3	0.5	●	●	●
2,1	0.1	3.2	0.5	●	●	●
2,3	0.1	3.5	0.5	●	●	●
2,6	0.1	4	0.5	●	●	●
3	0.1	4.5	0.5	●	●	●
3,5	0.1	5	0.5	●	●	●
4	0.1	5.5	0.5	●	●	●
4,5	0.1	6	0.5	●	●	●
5	0.1	6.5	0.5	●	●	●
5,5	0.1	7	0.5	●	●	●
6	0.1	8	0.5	●	●	●
6,5	0.5	9	1	●	●	●
7,5	0.5	10	1	●	●	●
8,5	0.5	11	1	●	●	●
9,5	0.5	12	1	●	●	●
10,5	0.5	13	1	●	●	●
11,5	0.5	14	1	●	●	●
12,5	0.5	15	1	●	●	●
13,5	0.5	16	1.5	●	●	●
14,5	0.5	17	1.5	●	●	●
15,5	0.5	18	1.5	●	●	●
16,5	0.5	19	1.5	●	●	●
17,5	0.5	20	1.5	●	●	●
18,5	0.5	21	1.5	●	●	●
19,5	0.5	22	1.5	●	●	●

Ordering Code (example):

Punch DIN 9861 Shape D / ISO 6752	=	223.
Material MAT	HSS	= 3.
Shaft diameter d ₁	4 mm	= 0400.
Length l ₁	71 mm	= 071
Order No		= 223.3.0400. 071

PUNCH DIN 9861 SHAPE CA



224.

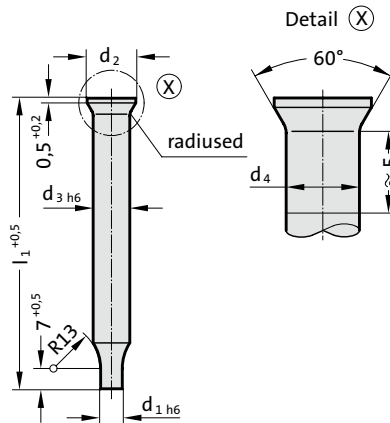

224. Punch DIN 9861 Shape CA

Gradation		d_1	d_2	d_3	d_4	l_1
d_1						
0,1 - 1,5	0.05	3	2	2.03	71	
1,55 - 2,95	0.05	4.5	3	3.03	71	

Material:

HSS

Order No 224.3.

Hardness:

Shaft 64 ± 2 HRC

Head 52 ± 3 HRC

HZ - TIN (HSS)

Order No 224.0.

Hardnes:

Surface 2300 HV 0,05

Head 52 ± 3 HRC

Description of FIBRO materials for tool and die components see at the beginning of Chapter E.

Execution:

Shaft precision ground. Head subsequently hot upset-forged and tempered; residual upset-buge below head normally much smaller than permissible acc. to DIN 9861.

Stock lengths: 71 mm.

Other lengths and diameters on request!

Ordering Code (example):

Punch DIN 9861 Shape CA	=	224.
Material MAT	HSS	= 3.
Cutting diameter d_1	1.55 mm	= 0155.
Length l_1	71 mm	= 071
Order No	=	224. 3.0155.071

PUNCH DIN 9861 SHAPE C

225.

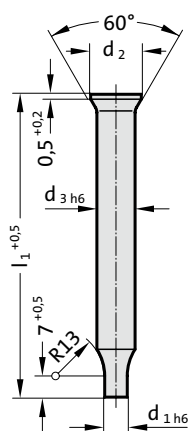

Material:

HSS
Order No 225.3.
Hardness:
Shaft 64 ± 2 HRC
Head 52 ± 3 HRC

HST
Order No 225.4.
Hardness:
Surface ≥ 950 HV 0,3
Head 52 ± 3 HRC

HZ - TIN (HSS)
Order No 225.0.
Hardness:
Surface 2300 HV 0,05
Head 52 ± 3 HRC

ASP 23 - ASP 2023
Order No 225.6.
Hardness:
Shaft 64 ± 2 HRC
Head 52 ± 3 HRC

 Description of FIBRO materials for tool and die components see at the beginning of Chapter E.

Execution:

Head hot upset-forged and tempered. Shaft and head subsequently precision plunge-ground for perfect concentricity and full interchangeability with replacement punches.

Stock lengths: 71 mm.
Other lengths and diameters on request!

Ordering Code (example):

Punch DIN 9861 Shape C	=	225.
Material MAT	HSS	= 3.
Cutting diameter d_1	1.55 mm	= 0155.
Length l_1	71 mm	= 071
Order No		= 225.3.0155.071

225. Punch DIN 9861 Shape C

	Gradation			
d_1	d_1	d_2	d_3	l_1
0,1 - 1,5	0.05	3	2	71
1,55 - 2,95	0.05	4.5	3	71

PUNCH SIMILAR TO DIN 9861 SHAPE CA



274.

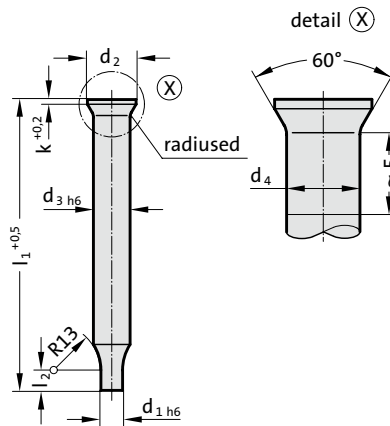

274. Punch similar to DIN 9861 Shape CA

Gradation		d_1	d_2	d_3	d_4	l_2	k	l_1	71	80	100
1 - 3,9	0.05	5.5	4	4.03	5 - 20	0.5			●	●	●
1,5 - 4,9	0.05	6.5	5	5.03	5 - 20	0.5			●	●	●
1,6 - 5,9	0.05	8	6	6.03	5 - 20	0.5			●	●	●
2,5 - 7,9	0.05	10	8	8.03	5 - 20	1			●	●	●
4 - 9,9	0.05	12	10	10.03	5 - 20	1			●	●	●
5 - 12,9	0.05	15	13	13.03	5 - 20	1			●	●	●
8 - 15,9	0.05	18	16	16.03	5 - 20	1.5			●	●	●

Description:

DIN 9861 restricts the range of stepped punches with conical head to shanks of 3 mm max. diameter and points of 2,95 mm max. diameter. Stepped punches of larger size are, however, quite popular owing to their rigidity and ability to sustain considerable stripping forces. In accommodation of this demand we supply larger sizes which are ground from stock sizes of the 222.-series.

Please select from those ranges and complete your order in accordance with the example on the right.

Material:

HSS

Order No 274.3.

Hardness:

Shaft 64 ± 2 HRC

Head 52 ± 3 HRC

HST

Order No 274.4.

Hardness:

Surface ≥ 950 HV 0,3

Head 52 ± 3 HRC

HZ - TIN (HSS)

Order No 274.0.

Hardness:

Surface 2300 HV 0,05

Head 52 ± 3 HRC

☞ Description of FIBRO materials for tool and die components see at the beginning of Chapter E.

Execution:

Shaft precision ground. Head subsequently hot upset-forged and tempered; residual upset-buge below head normally much smaller than permissible acc. to DIN 9861.

Stock lengths: 71, 80, 100 mm.

other lengths and diameters on request!

Ordering Code (example):

Punch similar to DIN 9861 Shape CA	= 274.
Material MAT	HSS = 3.
Shaft diameter d_3	8 mm = 0800.
Length l_1	71 mm = 071.
Cutting diameter d_1	2.5 mm = 0250.
Cutting length l_2	5 mm = 05
Order No	= 274. 3.0800. 071.0250. 05

PUNCH SIMILAR TO DIN 9861 SHAPE C

275.

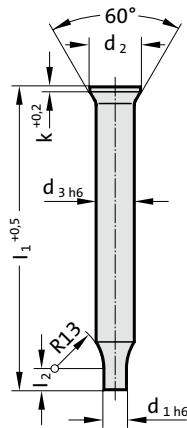

Description:

DIN 9861 restricts the range of stepped punches with conical head to shanks of 3 mm max. diameter and points of 2,95 mm max. diameter. Stepped punches of larger size are, however, quite popular owing to their rigidity and ability to sustain considerable stripping forces. In accommodation of this demand we supply larger sizes which are ground from stock sizes of the 223.-series

Please select from those ranges and complete your order in accordance with the example on the right.

Material:

HSS

Order No 275.3.

Hardness: Shaft 64 ± 2 HRC; Head 52 ± 3 HRC

HST

Order No 275.4.

Hardness: Surface ≥ 950 HV 0,3; Head 52 ± 3 HRC

HZ - TIN (HSS)

Order No 275.0.

Hardness: Surface 2300 HV 0,05; Head 52 ± 3 HRC

ASP 23 - ASP 2023

Order No 275.6.

Hardness: Shaft 64 ± 2 HRC; Head 52 ± 3 HRC

 Description of FIBRO materials for tool and die components see at the beginning of Chapter E.

Execution:

Head hot upset-forged and tempered. Shaft and head subsequently precision plunge-ground for perfect concentricity and full interchangeability with replacement punches.

Stock lengths: 71, 80, 100 mm.

other lengths and diameters on request!

275. Punch similar to DIN 9861 Shape C

d ₁	Gradation								
	d ₁	d ₂	d ₃	l ₂	k	l ₁	71	80	100
1 - 3,9	0.05	5.5	4	5 - 20	0.5		●	●	●
1,5 - 4,9	0.05	6.5	5	5 - 20	0.5		●	●	●
1,6 - 5,9	0.05	8	6	5 - 20	0.5		●	●	●
2,5 - 7,9	0.05	10	8	5 - 20	1		●	●	●
4 - 9,9	0.05	12	10	5 - 20	1		●	●	●
5 - 12,9	0.05	15	13	5 - 20	1		●	●	●
8 - 15,9	0.05	18	16	5 - 20	1.5		●	●	●

Ordering Code (example):

Punch similar to DIN 9861 Shape C	=	275.
Material MAT	HSS	= 3.
Shaft diameter d ₃	8 mm	= 0800.
Length l ₁	71 mm	= 071.
Cutting diameter d ₁	2.5 mm	= 0250.
Cutting length l ₂	5 mm	= 05
Order No	=	275.3.0800. 071.0250. 05

PUNCH VDI 3374



232.

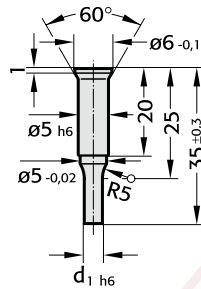

232. Punch VDI 3374

d_1	Gradation
2 - 5	d_1 0.1

Material:

HSS
Order No 232.3.
Hardness:
Shaft 64 ± 2 HRC
Head 52 ± 3 HRC

 Description of FIBRO materials for tool and die components see at the beginning of Chapter E.

Execution:

Punch head hot upset-forged. Shaft and shoulder precision plunge-ground.

Note:

Matching insert sleeves 233. and 234.

Ordering Code (example):

Punch VDI 3374	=	232.
Material MAT	HSS	= 3.
Cutting diameter d_1	2 mm	= 0200
Order No	=	232.3.0200

INSERT SLEEVE WITH THRUST PIN VDI 3374 SHAPE A

233.

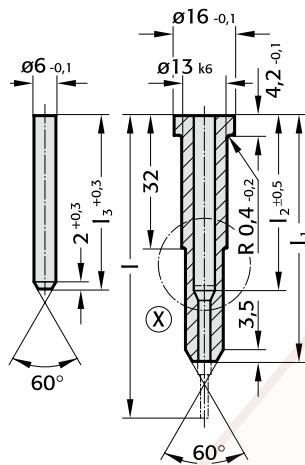

Material:

Insert sleeve:

Steel C 45 heat treated to 800 N/mm²

Thrust pin:

HWS, hardened 62 ± 2 HRC

Execution:

Insert sleeve: shaft precision ground

Thrust pin: ground

Note:

Matching punch 232.

233. Insert sleeve with thrust pin VDI 3374 Shape A

Order No	l	l ₁	l ₂	l ₃
233.7.048	63	48	29	29
233.7.057	71	57	37	37
233.7.065	80	65	46	46

INSERT SLEEVE WITH THRUST PIN VDI 3374 SHAPE B



234.

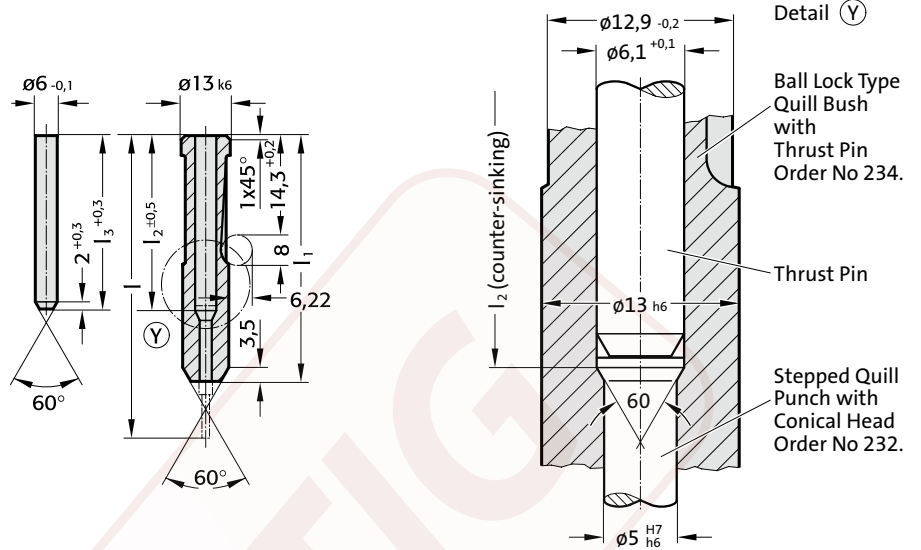

234. Insert sleeve with thrust pin VDI 3374 Shape B

Order No	l	l ₁	l ₂	l ₃
234.7.048	63	48	29	29
234.7.057	71	57	37	37
234.7.065	80	65	46	46

Material:

Insert sleeve:
Steel C 45 heat treated to 800 N/mm²
Thrust pin:
HWS, hardened 62 ± 2 HRC

Execution:

Insert sleeve: shaft precision ground
Thrust pin: ground

Note:

Matching punch 232.

PUNCH WITH TAPERED HEAD 30°, SHAPE D

2281.

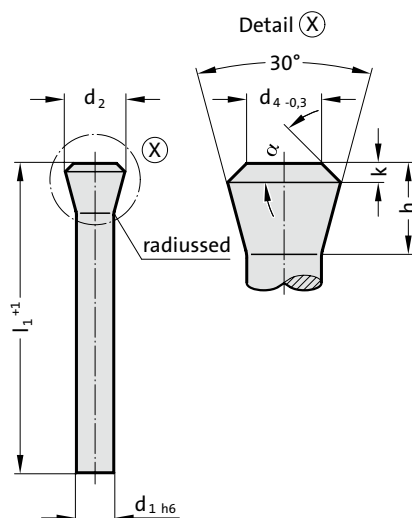

Material:

HSS

Order No 2281.3.

Hardness:

Shaft 58 + 2 HRC

Head ≤ 50 HRC

 Description of FIBRO materials for tool and die components see at the beginning of Chapter E.

Execution:

Head hot upset-forged and tempered. Shaft and head subsequently precision plunge-ground for perfect concentricity and full interchangeability with replacement punches.

2281. Punch with tapered head 30°, Shape D

d ₁	d ₂	d ₄	h	k	α ± 1°	l ₁	100	120
5.5	8.98	5.5	7.5	1	30		●	●
6	9.75	6	8	1	28		●	●
8	12.8	8	10	1	22.5		●	●
9	14.4	9	11	1	20		●	●
10	15.9	10	12	1	19		●	●
12	18.7	12	14	1.5	24			●
14	21.8	14	16	1.5	21			●
16	24.6	16	18	2	25			●

Ordering Code (example):

Punch with tapered head 30°, Shape D	=	2281.
Material MAT	HSS	= 3.
Shaft diameter d ₁	10 mm	= 1000.
Length l ₁	100 mm	= 100
Order No		= 2281. 3.1000. 100

PUNCH WITH TAPERED HEAD 30°,SHAPE C



2291.

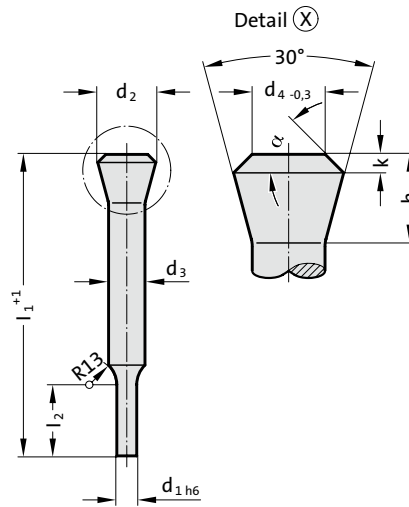

2291. Punch with tapered head 30°,Shape C

d_3	d_2	d_4	h	k	$\alpha \pm 1^\circ$	l_1	100	120
5.5	8.98	5.5	7.5	1	30		●	●
6	9.75	6	8	1	28		●	●
8	12.8	8	10	1	22.5		●	●
9	14.4	9	11	1	20		●	●
10	15.9	10	12	1	19		●	●
12	18.7	12	14	1.5	24			●
14	21.8	14	16	1.5	21			●
16	24.6	16	18	2	25			●

Material:

HSS
Order No 2291.3.
Hardness:
Shaft 58 + 2 HRC
Head \leq 50 HRC

Description of FIBRO materials for tool and die components see at the beginning of Chapter E.

Execution:

Head hot upset-forged and tempered. Shaft and head subsequently precision plunge-ground for perfect concentricity and full interchangeability with replacement punches.

d_1 and l_2 to customer's specifications!

Ordering Code (example):

Punch with tapered head 30°,Shape C	=	2291.
Material MAT	HSS	= 3.
Shaft diameter d_3	10 mm	= 1000.
Length l_1	100 mm	= 100.
Cutting diameter d_1	5 mm	= 0500.
Cutting length l_2	5 mm	= 005
Order No	=	2291.3.1000.100.0500.005

PUNCH WITH TAPERED HEAD, DIN 5118 SHAPE A

2284.3. Punch with tapered head, DIN 5118 Shape A

d ₁	d ₂	a	k	r	l	71	80	100	110
2	3	1	3	3.5		●	●	●	
2.1	3.2	1	3	5		●	●	●	
2.2	3.2	1	3	5		●	●	●	
2.3	3.5	1	3	5		●	●	●	
2.4	3.5	1	3	5		●	●	●	
2.5	3.5	1	3	5		●	●	●	
2.6	4	1	3	6.5		●	●	●	
2.7	4	1	3	6.5		●	●	●	
2.8	4	1	3	6.5		●	●	●	
2.9	4	1	3	6.5		●	●	●	
3.1	4.5	1	3	6.5		●	●	●	
3.2	4.5	1	3	6.5		●	●	●	
3.3	4.5	1	3	6.5		●	●	●	
3.4	4.5	1	3	6.5		●	●	●	
3.5	5	1	3	8		●	●	●	
3.6	5	1	3	8		●	●	●	
3.7	5	1	3	8		●	●	●	
3.8	5	1	3	8		●	●	●	
4.1	5.5	1.5	4	8		●	●	●	
4.2	5.5	1.5	4	8		●	●	●	
4.3	5.5	1.5	4	8		●	●	●	
4.4	5.5	1.5	4	8		●	●	●	
4.5	6	1.5	4	8		●	●	●	
4.6	6	1.5	4	8		●	●	●	
4.7	6	1.5	4	8		●	●	●	
4.8	6	1.5	4	8		●	●	●	
4.9	6	1.5	4	8		●	●	●	
5.1	7	1.5	4	10		●	●	●	
5.2	7	1.5	4	10		●	●	●	
5.5	8	1.5	4	10		●	●	●	
5.6	8	1.5	4	10		●	●	●	
6.1	9	1.5	4	10		●	●	●	
6.2	9	1.5	4	10		●	●	●	
6.3	9	1.5	4	10		●	●	●	
6.4	9	1.5	4	10		●	●	●	
6.5	10	1.5	4	12		●	●	●	●
7	10	1.5	4	12		●	●	●	●
7.5	11	1.5	4	12		●	●	●	●
7.7	11	1.5	4	12		●	●	●	●
8.1	11	1.5	4	12		●	●	●	●
8.5	13	1.5	4	15		●	●	●	●
9	13	1.5	4	15		●	●	●	●
9.5	14	1.5	4	15		●	●	●	●
10.5	15	1.5	4	15		●	●	●	●
11	15	1.5	4	15		●	●	●	●
11.5	16	1.5	4	15		●	●	●	●
12	16	1.5	4	15		●	●	●	●
12.5	17	1.5	4	15		●	●	●	●
13.5	18	1.5	4	15		●	●	●	●
14	18	1.5	4	15		●	●	●	●
14.5	19	1.5	4	15		●	●	●	●
15	19	1.5	4	15		●	●	●	●
15.5	20	1.5	4	15		●	●	●	●
17	21	1.5	4	15		●	●	●	●
18	22	1.5	4	15		●	●	●	●
19	23	1.5	4	15		●	●	●	●
19.5	25	1.5	4	15		●	●	●	●



2284.3.

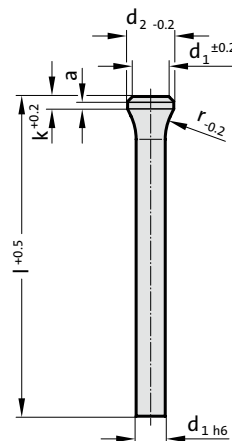

Material:

HSS
 Order No 2284.3.
 Hardness:
 Shaft 62-66 HRC
 Head 45-55 HRC

☞ Description of FIBRO materials for tool and die components see at the beginning of Chapter E.

Execution:

Shaft precision ground. Head subsequently hot upset-forged and tempered.

Note:

Matching piloted counterbore 2284.00.

Ordering Code (example):

Punch with tapered head, DIN 5118 Shape A		= 2284.3.
Shaft diameter d ₁	5.2 mm	= 0520.
Length l	80 mm	= 080
Order No		= 2284.3. 0520. 080

PUNCH WITH TAPERED HEAD, BLANK, DIN 5118 SHAPE A



2206.

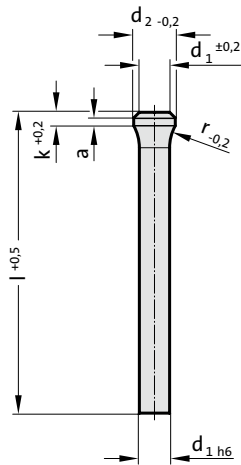

2206. Punch with tapered head, blank, DIN 5118 Shape A

d ₁ / Order No	d ₂	a	k	r	l (Order Code character)	71 (D)	80 (E)	90 (F)	100 (G)	120 (J)	150 (M)	200 (N)
3/(1)	4.5	1	3	6.5		●	●	●	●	●		
4/(2)	5.5	1.5	4	8		●	●	●	●	●		
5/(3)	7	1.5	4	10		●	●	●	●	●		
6/(4)	9	1.5	4	10		●	●	●	●	●		
8/(5)	11	1.5	4	12		●	●	●	●	●		
10/(6)	14	1.5	4	15		●	●	●	●	●	●	
13/(7)	17	1.5	4	15		●	●	●	●	●	●	●
16/(8)	20	1.5	4	15		●	●	●	●	●	●	●
20/(9)	25	1.5	4	15		●	●	●	●	●	●	●

Material:

HSS

Hardness:

Shaft 62-66 HRC

Head 45-55 HRC

Description of FIBRO materials for tool and die components see at the beginning of Chapter E.

Execution:

Shaft precision ground. Head subsequently hot upset-forged and tempered.

Note:

Matching piloted counterbore 2284.00.

Matching retainer ring 2284.00.01.

Ordering Code (example):

2206.7G

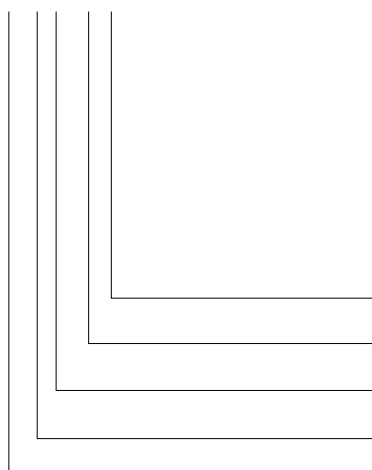

Length: l

100 mm

Diameter: d₁

13 mm

Type:
with tapered head

Execution:

blank

Punch:

without ejector pin

Order Code character
= (G)

Order No
= (7)

Order No
= (6)

Order No
= (0)

= 22

PUNCH WITH TAPERED HEAD, STEPPED, ROUND, DIN 5118 SHAPE B

2216.

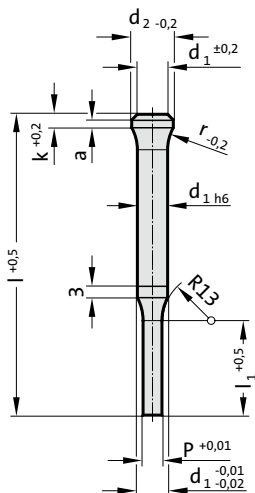

2216. Punch with tapered head, stepped, round, DIN 5118 Shape B

d ₁ / Order No	d ₂	p	l ₁ / Order No	a	k	r	l (Order Code character)	71 (D)	80 (E)	90 (F)	100 (G)	120 (J)	150 (M)	200 (N)
3 / (1)	4.5	0.8-2.9	8(1) 10(2)	1	3	6.5		●	●	●	●	●		
4 / (2)	5.5	1.0-3.9	8(1) 13(3)	1.5	4	8		●	●	●	●	●		
5 / (3)	7	1.5-4.9	13(3) 19(4)	1.5	4	10		●	●	●	●	●		
6 / (4)	9	1.6-5.9	13(3) 19(4)	1.5	4	10		●	●	●	●	●		
8 / (5)	11	2.5-7.9	19(4) 25(5)	1.5	4	12		●	●	●	●	●		
10 / (6)	14	4.0-9.9	19(4) 25(5)	1.5	4	15		●	●	●	●	●	●	
13 / (7)	17	5.0-12.9	19(4) 25(5)	1.5	4	15		●	●	●	●	●	●	●
16 / (8)	20	8.0-15.9	19(4) 25(5)	1.5	4	15		●	●	●	●	●	●	●
20 / (9)	25	12.0-19.9	19(4) 25(5)	1.5	4	15		●	●	●	●	●	●	●

Ordering Code (example):

2216.7G4.0720

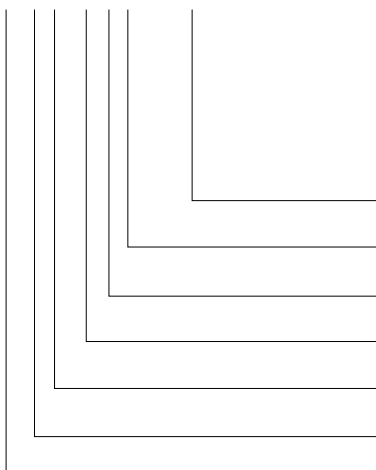

Shape: round
P = ø7,2 mm
Punch cutting length: l₁
19 mm
Length: l
100 mm
Diameter: d₁
13 mm
Type:
with tapered head
Execution:
round
Punch:
without ejector pin

= 0720
Order No
= (4)
Order Code character
= (G)
Order No
= (7)
Order No
= (6)
Order No
= (1)
= 22

Material:

HSS
Hardness:
Shaft 62-66 HRC
Head 45-55 HRC

Description of FIBRO materials for tool and die components see at the beginning of Chapter E.

Execution:

Shaft precision ground. Head subsequently hot upset-forged and tempered.

Note:

Matching piloted counterbore 2284.00.
Matching retainer ring 2284.00.01.

PUNCH WITH TAPERED HEAD, BLANK, WITH EJECTOR PIN, DIN 5118 SHAPE E



2706.

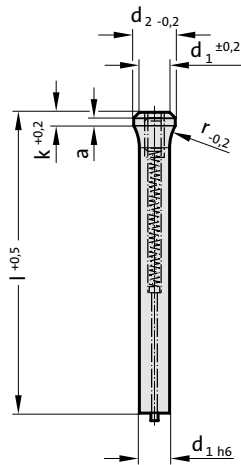

2706. Punch with tapered head, blank, with ejector pin, DIN 5118 Shape E

d ₁ / Order No	d ₂	a	k	r	l (Order Code character)	71 (D)	80 (E)	90 (F)	100 (G)	120 (J)
5 / (3)	7	1.5	4	10		●	●	●	●	●
6 / (4)	9	1.5	4	10		●	●	●	●	●
8 / (5)	11	1.5	4	12		●	●	●	●	●
10 / (6)	14	1.5	4	15		●	●	●	●	●
13 / (7)	17	1.5	4	15		●	●	●	●	●
16 / (8)	20	1.5	4	15		●	●	●	●	●
20 / (9)	25	1.5	4	15		●	●	●	●	●

Material:

HSS

Hardness:

Shaft 62-66 HRC

Head 45-55 HRC

☞ Description of FIBRO materials for tool and die components see at the beginning of Chapter E.

Execution:

Shaft precision ground. Head subsequently hot upset-forged and tempered.

Note:

Matching piloted counterbore 2284.00.

Matching retainer ring 2284.00.01.

Ordering Code (example):

2706.7G

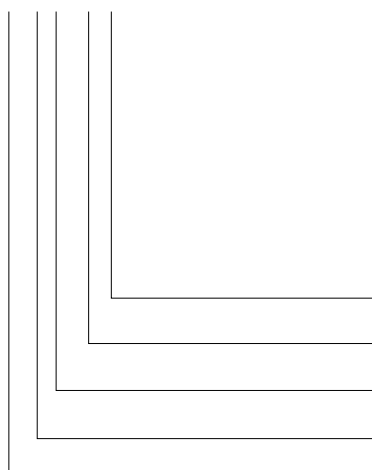

Length: l
100 mm
Diameter: d₁
13 mm
Type:
with tapered head
Execution:
blank
Punch:
with ejector pin

Order Code character
= (G)
Order No
= (7)
Order No
= (6)
Order No
= (0)
= 27

PUNCH WITH TAPERED HEAD, STEPPED, ROUND, WITH EJECTOR PIN, DIN 5118 SHAPE F

2716.

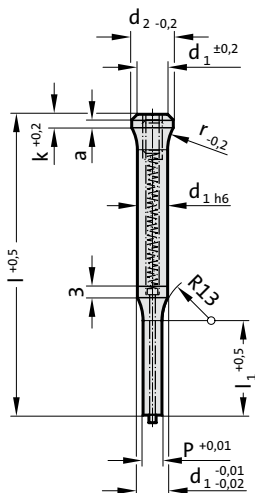

2716. Punch with tapered head, stepped, round, with ejector pin, DIN 5118 Shape F

d ₁ / Order No	d ₂	P	l ₁ / Order No	a	k	r	l (Order Code character)	71 (D)	80 (E)	90 (F)	100 (G)	120 (J)
5 / (3)	7	2 - 4.9	13 (3) 19 (4)	1.5	4	10		●	●	●	●	●
6 / (4)	9	2.5 - 5.9	13 (3) 19 (4)	1.5	4	10		●	●	●	●	●
8 / (5)	11	4 - 7.9	19 (4) 25 (5)	1.5	4	12		●	●	●	●	●
10 / (6)	14	5 - 9.9	19 (4) 25 (5)	1.5	4	15		●	●	●	●	●
13 / (7)	17	6 - 12.9	19 (4) 25 (5)	1.5	4	15		●	●	●	●	●
16 / (8)	20	8 - 15.9	19 (4) 25 (5)	1.5	4	15		●	●	●	●	●
20 / (9)	25	10 - 19.9	19 (4) 25 (5)	1.5	4	15		●	●	●	●	●

Ordering Code (example):

2716.7G4.0720

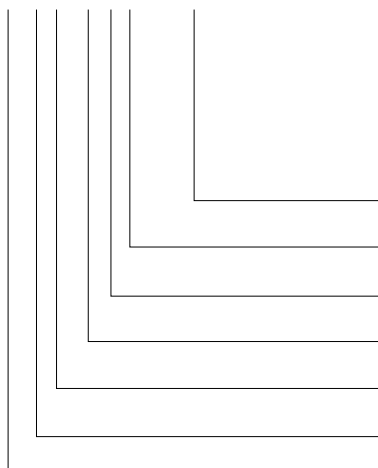

Shape: round

P = ø7,2 mm

Punch cutting length: l₁
19 mm

Length: l
100 mm

Diameter: d₁
13 mm

Type:
with tapered head

Execution:
round

Punch:
with ejector pin

= 0720

Order No

= (4)

Order Code character

= (G)

Order No

= (7)

Order No

= (6)

Order No

= (1)

= 27

Material:

HSS

Hardness:

Shaft 62-66 HRC

Head 45-55 HRC

☞ Description of FIBRO materials for tool and die components see at the beginning of Chapter E.

Execution:

Shaft precision ground. Head subsequently hot upset-forged and tempered.

Note:

Matching piloted counterbore 2284.00.

Matching retainer ring 2284.00.01.

PILOTED COUNTERBORE FOR TAPERED-HEAD PUNCH



2284.00.

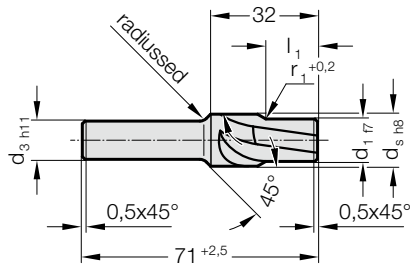

Material:

HSS, hardened 62-66 HRC

Execution:

Tempered and ground.

2284.00. Piloted counterbore for tapered-head punch

d ₁	d _s	d ₃	r ₁	l ₁
2	3.3	3.3	3.5	5
2.1	3.5	3.5	5	5
2.2	3.5	3.5	5	5
2.3	3.8	3.8	5	5
2.4	3.8	3.8	5	5
2.5	3.8	3.8	5	5
2.6	4.3	4.3	6.5	7
2.7	4.3	4.3	6.5	7
2.8	4.3	4.3	6.5	7
2.9	4.3	4.3	6.5	7
3	4.9	4.9	6.5	7
3.1	4.9	4.9	6.5	7
3.2	4.9	4.9	6.5	7
3.3	4.9	4.9	6.5	7
3.4	4.9	4.9	6.5	7
3.5	5.4	5.4	8	8
3.6	5.4	5.4	8	8
3.7	5.4	5.4	8	8
3.8	5.4	5.4	8	8
4	5.9	5.9	8	8
4.1	5.9	5.9	8	8
4.2	5.9	5.9	8	8
4.3	5.9	5.9	8	8
4.4	5.9	5.9	8	8
4.5	6.4	6.4	8	8
4.6	6.4	6.4	8	8
4.7	6.4	6.4	8	8
4.8	6.4	6.4	8	8
4.9	6.4	6.4	8	8
5	7.4	7.4	10	10
5.1	7.4	7.4	10	10
5.2	7.4	7.4	10	10
5.5	8.5	8.5	10	10
5.6	8.5	8.5	10	10
6	9.5	9.5	10	10
6.1	9.5	9.5	10	10
6.2	9.5	9.5	10	10
6.3	9.5	9.5	10	10
6.4	9.5	9.5	10	10
6.5	10.5	10.5	12	12
7	10.5	10.5	12	12
7.5	11.5	11.5	12	12
7.7	11.5	11.5	12	12
8	11.5	11.5	12	12
8.1	11.5	11.5	12	12
8.5	13.5	13	15	12
9	13.5	13	15	12
9.5	14.5	13	15	12
10	14.5	13	15	12
10.5	15.5	13	15	15
11	15.5	13	15	15
11.5	16.5	13	15	15
12	16.5	13	15	15
12.5	17.5	13	15	15
13	17.5	13	15	15
13.5	18.5	13	15	15
14	18.5	13	15	15
14.5	19.5	13	15	15
15	19.5	13	15	15
15.5	20.5	13	15	15
16	20.5	13	15	15
17	21.5	16	15	15
18	22.5	16	15	15
19	23.5	16	15	15
19.5	25.5	16	15	15
20	25.5	16	15	15

Ordering Code (example):

Piloted counterbore for tapered-head punch	=	2284.00.
Punch shaft diameter d ₁	5.6 mm	0560
Order No	=	2284.00. 0560

MOUNTING RING FOR PUNCH WITH TAPERED HEAD

2284.00.01.

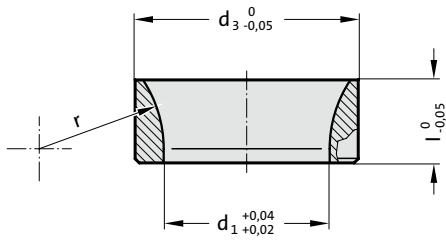

2284.00.01. Mounting ring for punch with tapered head

Order No	d ₁	d ₂	d ₃	d ₄	l	l ₁	r
2284.00.01.0300	3	4.5	5.9	6	4	7	6.5
2284.00.01.0400	4	5.5	6.9	7	4	8	8
2284.00.01.0500	5	7	8.9	9	7	11	10
2284.00.01.0600	6	9	10.9	11	7	11	10
2284.00.01.0800	8	11	12.9	13	8	12	12
2284.00.01.1000	10	14	15.9	16	9	13	15
2284.00.01.1300	13	17	18.9	19	9	13	15
2284.00.01.1600	16	20	21.9	22	9	13	15
2284.00.01.2000	20	25	26.9	27	10	14	15

Mounting example

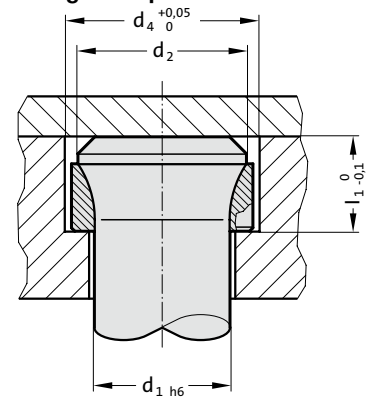

Material:

Tool steel, heat-treated

Note:

Used for punch with tapered neck

ASSEMBLY GUIDE LINES FOR HEAD TYPE PUNCHES WITH ROUND POINTS

Description:

Head type punches with round point (DIN 9844) are intended for floating assembly in the punch retainer. If there is sufficient clearance between the cutting punch, punch mounting plate and pressure plate, bending stresses can be avoided that can be caused by misalignments.

- a) for rigid installation
- b) with forced centring by the countersunk head. With punches held in this manner, a clear separation between transmission of perforation force and guiding is achieved.

In order to facilitate assembly of punches of different diameters, the height of the heads is standardized to $4^{+0.2}$ mm (DIN 9844).

Guide Lines:

excerpts from DIN 9844, page 5

d_1 max. = stock thickness

Stripping force:

for d_1 from 1 to 5 mm = 20% of the cutting force

for d_1 from 5.1 to 16 mm = 10% of the cutting force

Cutting material: max. $\sigma_{dB} = 400 \text{ N/mm}^2$

Punch retainer plate made from St 50-2 with $\sigma_{D perm.} = 300 \text{ N/mm}^2$

Locating hole in the punch retainer plate: $1.05 \times d_1$ or d_2

Clearance punch head/percussion plate = 0.02 mm.

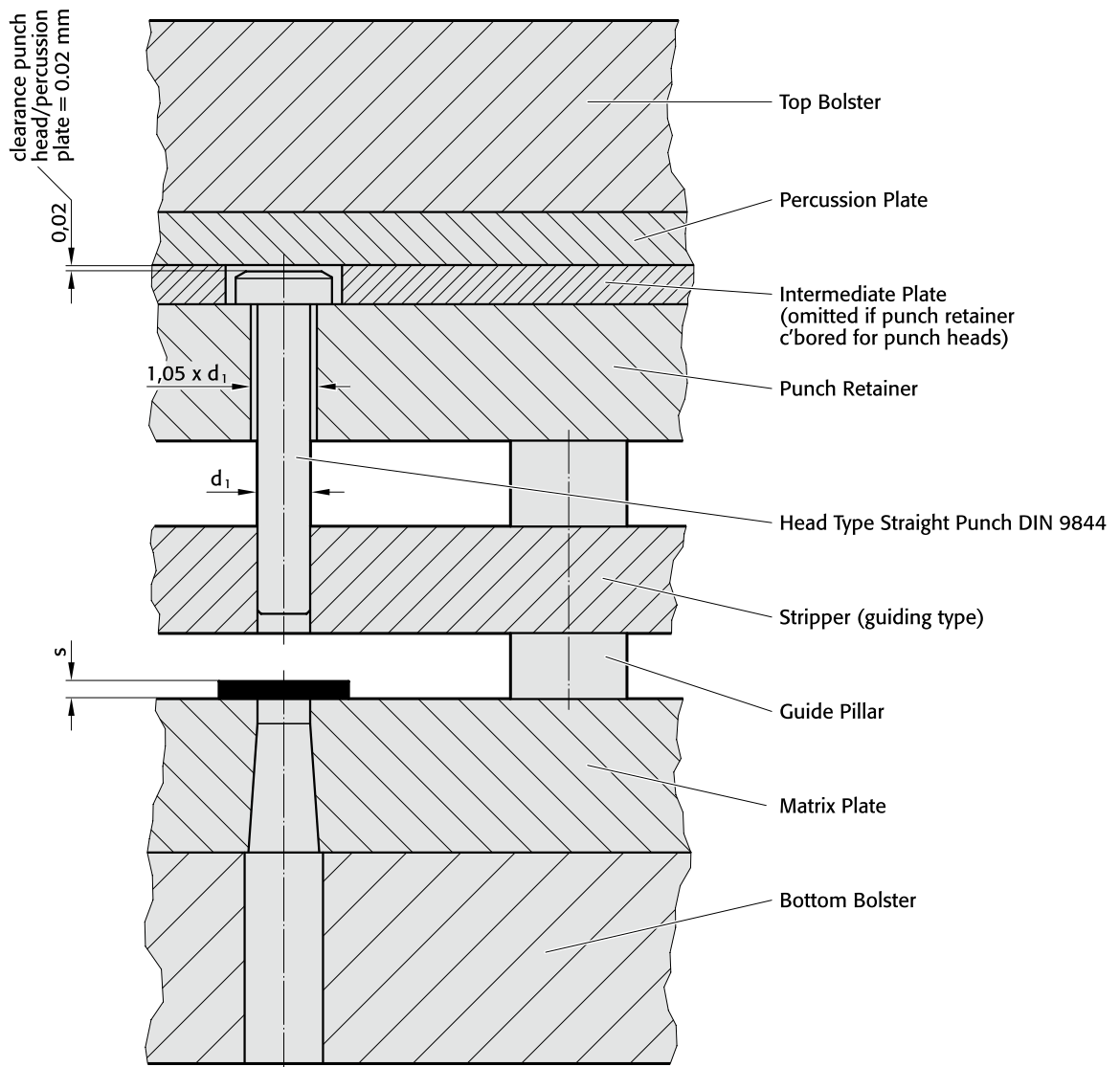

PUNCH DIN 9844, SHAPE A

220.

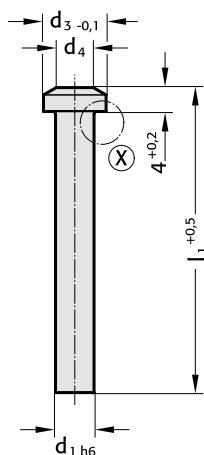
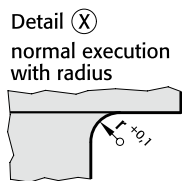

$$d_4 = d_1^{+0,5}$$



Material:

HSS
Order No 220.3.
Hardness:
Shaft 64 ± 2 HRC
Head 52 ± 3 HRC

HST
Order No 220.4.
Hardness:
Surface ≥ 950 HV 0,3
Head 52 ± 3 HRC

Description of FIBRO materials for tool and die components see at the beginning of Chapter E.

Execution:

Punch head hot upset-forged. Shaft and shoulder precision plunge-ground.

Stock lengths: 71, 90, 112 mm.
other lengths and diameters on request!

220. Punch DIN 9844, Shape A

d ₁	Gradation			l ₁	71	90	112
	d ₁	d ₃	r				
2 - 2,2	0.1	3.6	0.2		●	●	●
2,3 - 2,5	0.1	4	0.2		●	●	●
2,6 - 2,8	0.1	4.5	0.3		●	●	●
3,6 - 4	0.1	7	0.3		●	●	●
2,9 - 3,2	0.1	5	0.3		●	●	●
3,3 - 3,5	0.1	6	0.3		●	●	●
4,6 - 5	0.1	8.5	0.5		●	●	●
5,1 - 5,4	0.1	9	0.5		●	●	●
4,1 - 4,5	0.1	8	0.5		●	●	●
5,5 - 5,9	0.1	9.5	0.5		●	●	●
6 - 6,4	0.1	10	0.5		●	●	●
7,5 - 8	0.5	12	0.7		●	●	●
8,5 - 9	0.5	13	0.7		●	●	●
6,5 - 7	0.5	10.8	0.7		●	●	●
9,5 - 10	0.5	14.5	0.7		●	●	●
10,5 - 11	0.5	16	1		●	●	●
11,5 - 12,5	0.5	18	1		●	●	●
13 - 14,5	0.5	20	1		●	●	●
15 - 16	0.5	22	1		●	●	●

Ordering Code (example):

Punch DIN 9844, Shape A	=	220.
Material MAT	HSS	= 3.
Cutting diameter d ₁	5.5 mm	= 0550.
Length l ₁	71 mm	= 071
Order No	=	220. 3.0550. 071

PUNCH DIN 9844, SHAPE B



221.

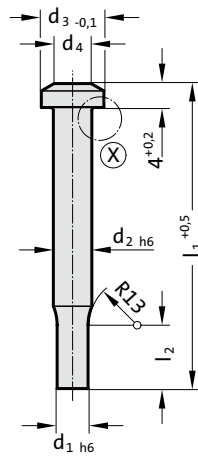

$$d_4 = d_1^{+0.5}$$

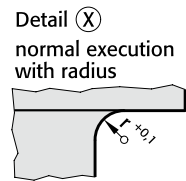

221. Punch DIN 9844, Shape B

Gradation										
d_1	d_1	d_2	d_3	l_2	r	l_1	71	90	112	
0,1 - 1,9	0.05	2	3.6	7	0.2		●	●	●	
1,95 - 2,4	0.05	2.5	4	7	0.2		●	●	●	
2,5 - 3,1	0.1	3.2	5	7	0.3		●	●	●	
3,2 - 3,9	0.1	4	7	7	0.3		●	●	●	
4 - 4,9	0.1	5	8.5	7	0.5		●	●	●	
5 - 6,2	0.1	6.3	10	7	0.5		●	●	●	
6,3 - 7,9	0.1	8	12	16	0.7		●	●	●	
8 - 9,9	0.1	10	14.5	16	0.7		●	●	●	
10 - 12,4	0.1	12.5	18	16	1		●	●	●	
12,5 - 15,9	0.1	16	22	16	1		●	●	●	

Material:

HSS
 Order No 221.3.
 Hardness:
 Shaft 64 ± 2 HRC
 Head 52 ± 3 HRC

HST
 Order No 221.4.
 Hardness:
 Surface ≥ 950 HV 0,3
 Head 52 ± 3 HRC

Description of FIBRO materials for tool and die components see at the beginning of Chapter E.

Execution:

Punch head hot upset-forged. Shaft and shoulder precision plunge-ground.

Stock lengths: 71, 90, 112 mm.
 other lengths and diameters on request!

Ordering Code (example):

Punch DIN 9844, Shape B	=	221.
Material MAT	HSS =	3.
Cutting diameter d_1	5 mm =	0500.
Length l_1	71 mm =	071
Order No	=	221.3.0500. 071

PUNCH SIMILAR TO VDI 3374

266.

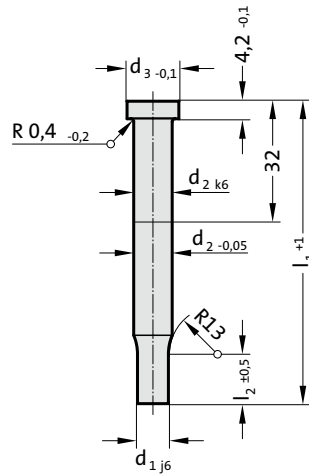

Material:

HSS
Order No 266.3.
Hardness:
Shaft 62 ± 2 HRC
Head 45 ± 5 HRC

Description of FIBRO materials for tool and die components see at the beginning of Chapter E.

Execution:

Punch head hot upset-forged. Shaft and shoulder precision plunge-ground.

Stock lengths: 71, 80 mm.
other lengths and diameters on request!

266. Punch similar to VDI 3374

d ₁	Gradation		d ₂	d ₃	l ₂	l ₁	71	80
	d ₁	d ₂						
5 - 8,9	0.1	10	13	13		●	●	
9 - 11,9	0.1	13	16	13		●	●	
12 - 15,9	0.1	16	19	13		●	●	
16 - 19,5	0.5	20	24	13		●	●	
20 - 24,5	0.5	25	29	13		●	●	

Ordering Code (example):

Punch similar to VDI 3374 = 266.
Material MAT HSS = 3.
Cutting diameter d₁ 12 mm = 1200.
Length l₁ 71 mm = 071
Order No = 266. 3.1200. 071

PUNCH WITH EJECTOR PIN



267.

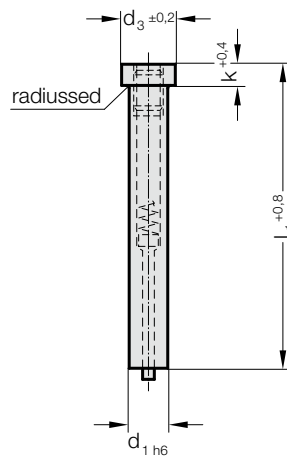

267. Punch with ejector pin

d _{1 h6}	d ₃	k	l ₁	60	71	80	90	100
5	8	5		●	●	●	●	●
6	9	5		●	●	●	●	●
8	11	5		●	●	●	●	●
10	13	5		●	●	●	●	●
13	16	5		●	●	●	●	●
16	19	6.4		●	●	●	●	●
20	23	6.4		●	●	●	●	●
25	28	6.4		●	●	●	●	●

Material:

HSS

Order No 267.3.

Hardness:

Shaft 64 ± 2 HRC

Head 52 ± 5 HRC

Description of FIBRO materials for tool and die components see at the beginning of Chapter E.

Execution:

Punch head hot upset-forged. Shaft and shoulder precision plunge-ground.

Ordering Code (example):

Punch with ejector pin	=	267.
Material MAT	HSS	= 3.
Shaft diameter d ₁	13 mm	= 1300.
Length l ₁	60 mm	= 060
Order No	=	267. 3.1300.060

PUNCH WITH EJECTOR PIN, STEPPED, SHORT POINT

268.

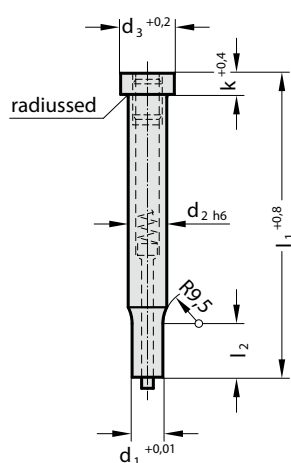
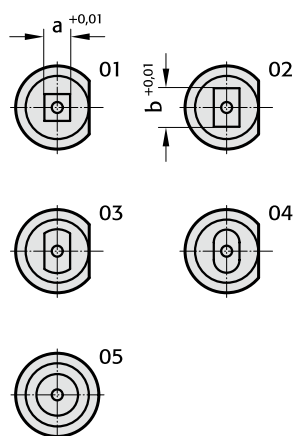

Material:

HSS
Order No 268.3.
Hardness:
Shaft 64 ± 2 HRC
Head 52 ± 5 HRC

 Description of FIBRO materials for tool and die components see at the beginning of Chapter E.

Execution:

Punch head hot upset-forged. Shaft and shoulder precision plunge-ground.

Key flats parallel with longest size of shape, unless otherwise specified.

Note:

At a cutting gap of ≤ 0.04 mm, FIBRO rounds off sharp edges for shape 01 and shape 02, if punch and matrix are ordered together. This reduces the assembly time and the risk of an edge break during operation.

268.

Punch with ejector pin, stepped, short point

d_1	d_2	d_3	k	l_2	a_{min}	l_1	60	71	80	90	100
1.6 - 4.9	5	8	5	7	1.6		●	●	●	●	●
2.3 - 5.9	6	9	5	7	2.3		●	●	●	●	●
3.2 - 7.9	8	11	5	13	3.2		●	●	●	●	●
4.8 - 9.9	10	13	5	13	4.8		●	●	●	●	●
4.8 - 12.9	13	16	5	13	4.8		●	●	●	●	●
5.5 - 15.9	16	19	6.4	13	5.5		●	●	●	●	●
5.5 - 19.9	20	23	6.4	13	5.5		●	●	●	●	●
6.5 - 24.9	25	28	6.4	13	6.5		●	●	●	●	●

Ordering Code (example):

Punch with ejector pin, stepped, short point	=	268.3.
Shaft diameter d_2	13 mm =	1300.
Length l_1	60 mm =	060.
Cutting form FORM	square =	01.
Cutting form width a	4.8 mm =	0480.
Cutting form length b	4.8 mm =	0480
Order No	=	268.3. 1300.060. 01.0480. 0480

PUNCH WITH EJECTOR PIN, STEPPED, LONG POINT



269.

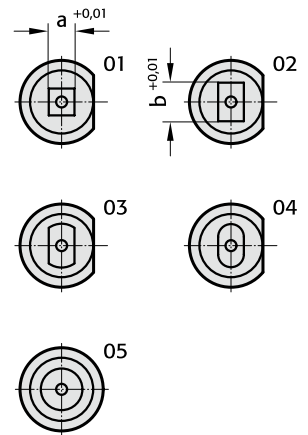
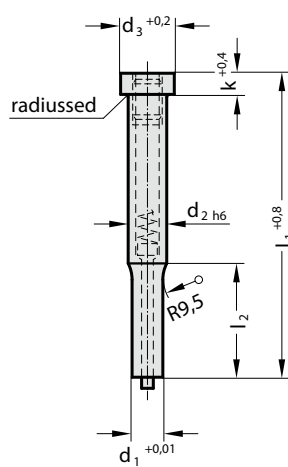

269. Punch with ejector pin, stepped, long point

d ₁	d ₂	d ₃	k	l ₂	a _{min}	l ₁	60	71	80	90	100
2,3 - 5,9	6	9	5	17,5	2,3		●	●	●	●	●
3,2 - 7,9	8	11	5	25	3,2		●	●	●	●	●
4,8 - 9,9	10	13	5	28	4,8		●	●	●	●	●
4,8 - 12,9	13	16	5	28	4,8		●	●	●	●	●
5,5 - 15,9	16	19	6,4	28	5,5		●	●	●	●	●
5,5 - 19,9	20	23	6,4	28	5,5		●	●	●	●	●
6,5 - 24,9	25	28	6,4	28	6,5		●	●	●	●	●

Material:

HSS
 Order No 269.3.
 Hardness:
 Shaft 64 ± 2 HRC
 Head 52 ± 5 HRC

☞ Description of FIBRO materials for tool and die components see at the beginning of Chapter E.

Execution:

Punch head hot upset-forged. Shaft and shoulder precision plunge-ground.

Key flats parallel with longest size of shape, unless otherwise specified.

Note:

At a cutting gap of ≤ 0.04 mm, FIBRO rounds off sharp edges for shape 01 and shape 02, if punch and matrix are ordered together. This reduces the assembly time and the risk of an edge break during operation.

Ordering Code (example):

Punch with ejector pin, stepped, long point	=	269.3.
Shaft diameter d ₂	13 mm =	1300.
Length l ₁	60 mm =	060.
Cutting form FORM	square =	01.
Cutting form width a	4.8 mm =	0480.
Cutting form length b	4.8 mm =	0480
Order No	=	269.3. 1300. 060. 01.0480. 0480

SINTERED HARD METAL HIP-DENSIFIED

The HIP process (hot isostatic pressing) consists of a special densification treatment of WC – Co – hard metals

In this process, which is widely used in hard metal technology, the material is post-compacted under high pressure (1.2-3 kbar) in a high-temperature furnace below the sintering temperature after sintering.

This process reduces the residual porosity.

The reduction in porosity leads to an improvement in the strength properties and thus to an increase in the service life of the tools for non-cutting shaping.

As can be seen from the diagrams and tables, both compressive and flexural strength are improved.

For stamping die tooling, hard metal types of medium tungsten particle size, with a cobalt content of 9 to 12%, have been found successful in a wide field of applications.

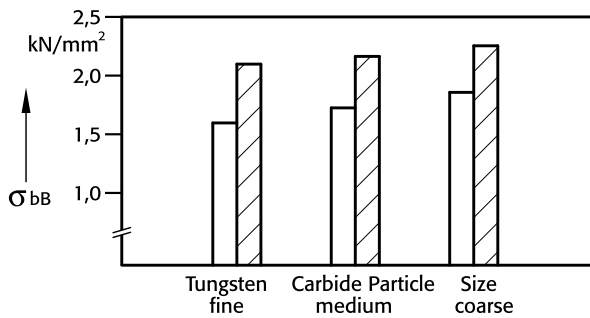

a) influence of crystallite size of hard metal phase
left: sintered only
right: sintered and HIP-treated).

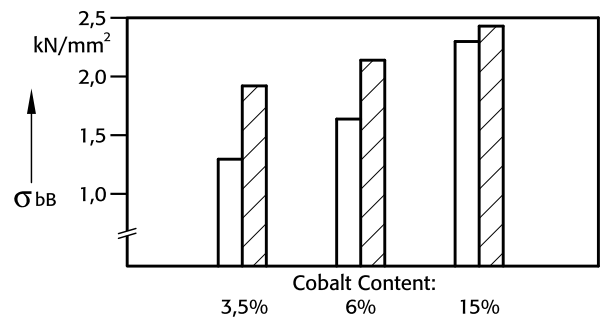

b) Influence of the cobalt content, sample condition as in figure a. Flexural strength σ_{bb} of a WC-6Co alloy in the sintered and HIP-treated state as a function of various influencing variables. Porosity in sintered condition: $\geq A1$
left, not shaded: Sintered condition
right, shaded: HIP-treated.

Change of Sintered Hard Metal by hot isostatic pressing

Tungsten carbide – particle size	Co %	Hardness HV ₃₀		Flexural Strength N/mm ²	
		before	after	before	after
fine	3	1800	no changes	1200	1700
	6	1650		1500	2300
	9	1400		2000	2600
medium	6	1600		2000	2600
	9	1450		2350	2700
	12	1300		2450	2900
coarse	15	1200		2700	2850
	6	1400		1900	2250
	8	1350		2300	2600
	10	1200	2650	2850	

PUNCH SIMILAR TO DIN 9844, SHAPE A

270.

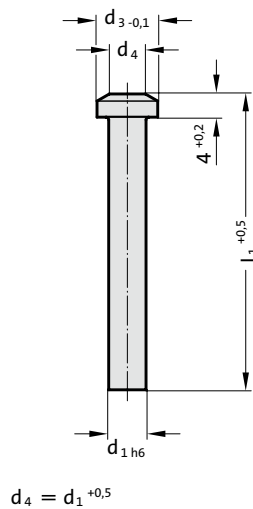

Material:

Tungsten-Cobalt-Carbide
Order No 270.9.

Execution:

Shaft precision ground.
Head: Steel, brazed to shaft or Tungsten-Cobalt Carbide.

Other diameters and lengths on request.

270. Punch similar to DIN 9844, Shape A

Gradation							
d_1	d_1	d_3	r	l_1	71	90	112
1	0.1	3.6	0.2		●	●	●
2.3	0.1	4	0.2		●	●	●
2.6	0.1	4.5	0.3		●	●	●
2.9	0.1	5	0.3		●	●	●
3.3	0.1	6	0.3		●	●	●
3.6	0.1	7	0.3		●	●	●
4.1	0.1	8	0.5		●	●	●
4.6	0.1	8.5	0.5		●	●	●
5.1	0.1	9	0.5		●	●	●
5.5	0.1	9.5	0.5		●	●	●
6	0.1	10	0.5		●	●	●
6.5	0.5	10.8	0.7		●	●	●
7.5	0.5	12	0.7		●	●	●
8.5	0.5	13	0.7		●	●	●
9.5	0.5	14.5	0.7		●	●	●
10.5	0.5	16	1		●	●	●
11.5	0.5	18	1		●	●	●
13	0.5	20	1		●	●	●
15	0.5	22	1		●	●	●

Ordering Code (example):

Punch similar to DIN 9844, Shape A	=	270.9.
Shaft diameter d_1	4.7 mm =	0470.
Length l_1	71 mm =	071
Order No	=	270.9. 0470. 071

PUNCH SIMILAR TO DIN 9844, SHAPE B



271.

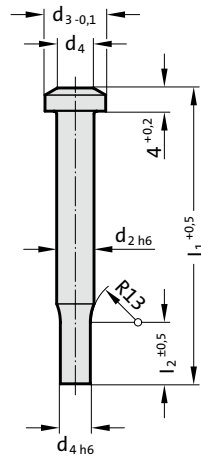

$$d_4 = d_1^{+0,5}$$

271. Punch similar to DIN 9844, Shape B

Gradation									71	90	112
d_1	d_1	d_2	d_3	l_2	r	l_1					
0.5	0.05	2	3.6	7	0.2		●	●	●		
1.95	0.05	2.5	4	7	0.2		●	●	●		
2.5	0.1	3.2	5	7	0.3		●	●	●		
3.2	0.1	4	7	7	0.3		●	●	●		
4	0.1	5	8.5	7	0.5		●	●	●		
5	0.1	6.3	10	7	0.5		●	●	●		
6.3	0.1	8	12	16	0.7		●	●	●		
8	0.1	10	14.5	16	0.7		●	●	●		
10	0.1	12.5	18	16	1		●	●	●		
12.5	0.1	16	22	16	1		●	●	●		

Material:

Tungsten-Cobalt-Carbide
Order No 271.9.

Execution:

Shaft precision ground.
Head: Steel, brazed to shaft or Tungsten-Cobalt Carbide.

Other diameters and lengths on request.

Ordering Code (example):

Punch similar to DIN 9844, Shape B	=	271.9.
Cutting diameter d_1	7.3 mm =	0730.
Length l_1	71 mm =	071
Order No	=	271.9.0730.071

PUNCH SIMILAR TO DIN 9861, SHAPE D

272.

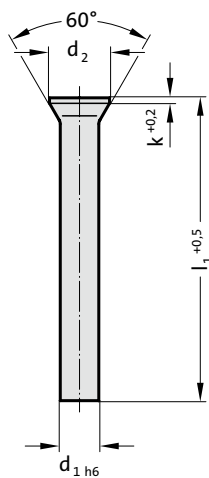

Material:

Tungsten-Cobalt-Carbide

Order No 272.9.

Execution:

Shaft precision ground.

Head: Steel, brazed to shaft or Tungsten-Cobalt Carbide.

Other diameters and lengths on request.

272. Punch similar to DIN 9861, Shape D

d ₁	Gradation			l ₁	71	80	100
	d ₁	d ₂	k				
1.5	0.1	2.2	0.5		●	●	●
2	0.1	3	0.5		●	●	●
3 - 3.4	0.1	4.5	0.5		●	●	●
4 - 4.4	0.1	5.5	0.5		●	●	●
5 - 5.4	0.1	6.5	0.5		●	●	●
6 - 6.4	0.1	8	0.5		●	●	●
1.6 - 1.7	0.1	2.5	0.5		●	●	●
1.8 - 1.9	0.1	2.8	0.5		●	●	●
2.1 - 2.2	0.1	3.2	0.5		●	●	●
2.3 - 2.5	0.1	3.5	0.5		●	●	●
2.6 - 2.9	0.1	4	0.5		●	●	●
3.5 - 3.9	0.1	5	0.5		●	●	●
4.5 - 4.9	0.1	6	0.5		●	●	●
5.5 - 5.9	0.1	7	0.5		●	●	●
6.5 - 7	0.5	9	1		●	●	●
7.5 - 8	0.5	10	1		●	●	●
8.5 - 9	0.5	11	1		●	●	●
9.5 - 10	0.5	12	1		●	●	●
10.5 - 11	0.5	13	1		●	●	●
11.5 - 12	0.5	14	1		●	●	●
12.5 - 13	0.5	15	1		●	●	●
13.5 - 14	0.5	16	1.5		●	●	●
14.5 - 15	0.5	17	1.5		●	●	●
15.5 - 16	0.5	18	1.5		●	●	●

Ordering Code (example):

Punch similar to DIN 9861, Shape D = 272.9.

Shaft diameter d₁ 5 mm = 0500.

Length l₁ 71 mm = 071

Order No = 272.9. 0500. 071

PUNCH SIMILAR TO DIN 9861, SHAPE C



273.

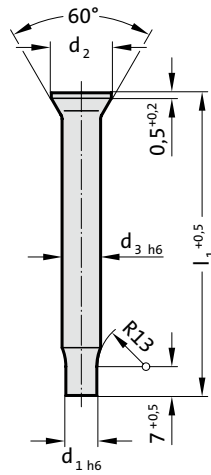

273. Punch similar to DIN 9861, Shape C

d_1	Gradation	d_2	d_3	l_1
0.5 - 1.5	0.05	3	2	71
1.55 - 2.95	0.05	4.5	3	71

Material:

Tungsten-Cobalt-Carbide
Order No 273.9.

Execution:

Shaft precision ground.
Head: Steel, brazed to shaft or Tungsten-Cobalt Carbide.

Other diameters and lengths on request.

Ordering Code (example):

Punch similar to DIN 9861, Shape C	=	273.9.
Cutting diameter d_1	1.75 mm =	0175.
Length l_1	71 mm =	071
Order No	=	273.9. 0175.071

BALL-LOCK PUNCHES



BALL-LOCK PUNCH - EXAMPLE ORDERS

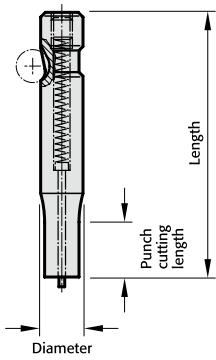

Note: See table for standard dimensions
Special dimensions to order

2 2 4 2 . 2 F 1 . 0 6 5 0 . 0 4 5 0 . B

Punch:
22 without ejector pin
27 with ejector pin

Execution:	Order No
○ blank	= 0
⊙ round	= 1
□ square	= 2
▭ rectangular	= 3
⊔ slot	= 4
▭ rectangle with radiused corners	= 5
▽ Pilot pin with tapered tip	= 6
⊔ Pilot pin parabolic tip	= 7
special shapes	= 9

Type:	Order No
light	= 2
heavy	= 3
punch larger, light	= 4
punch larger, heavy	= 5

Punch cutting length: l_1	Order No
13	= 1
19	= 2
25	= 3
30	= 4
special	= X

Diameter: d_2	Order No
6 (light duty only)	= 1
10	= 2
13	= 3
16	= 4
20	= 5
25	= 6
32	= 7
38 (light duty only)	= 8
40 (heavy duty only)	= 9

Length: l	Order Code character
50	= A
56	= B
63	= C
71	= D
80	= E
90	= F
100	= G
110	= H
125	= J
140	= K
150	= L
175	= M
200	= N
special	= X

Form: slot width = 4.5 mm	Order Code character
0°	= A
90°	= B
180°	= C
270°	= D
special	= X

Ordering Code (example):

2 2 4 2 . 2 F 1 . 0 6 5 0 . 0 4 5 0 . B

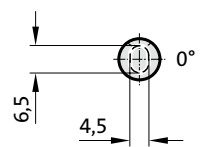
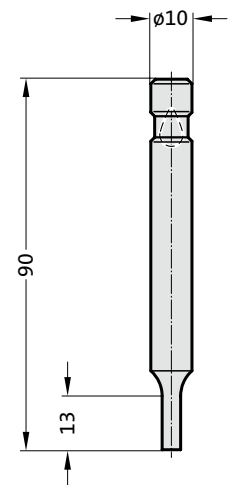
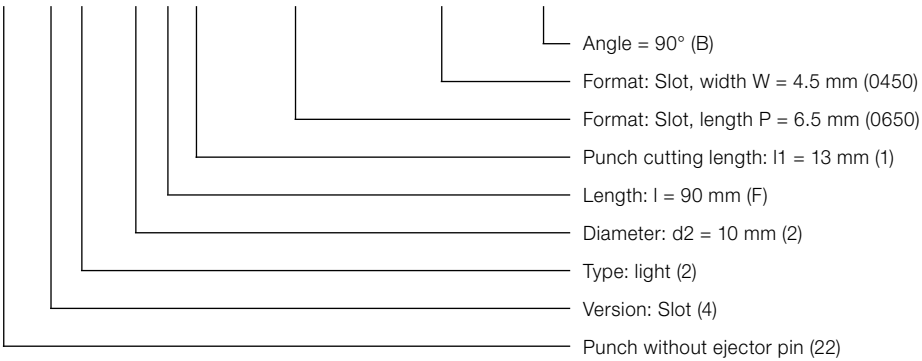

BALL-LOCK PUNCH, BLANK, LIGHT DUTY

2202.

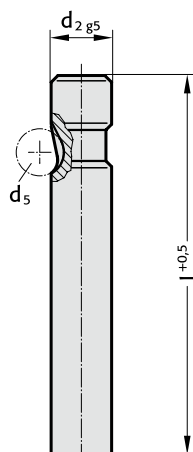

2202. Ball-Lock punch, blank, light duty

d ₂ / Order No	d ₅	l / (Order Code character)	63 (C)	71 (D)	80 (E)	90 (F)	100 (G)	110 (H)	125 (J)	140 (K)	150 (L)	175 (M)	200 (N)
6 / (1)	6		●	●	●	●	●						
10 / (2)	8		●	●	●	●	●	●					
13 / (3)	8		●	●	●	●	●	●	●	●		●	
16 / (4)	8		●	●	●	●	●	●	●	●	●	●	
20 / (5)	8		●	●	●	●	●	●	●	●	●	●	●
25 / (6)	8		●	●	●	●	●	●	●	●	●	●	●
32 / (7)	8			●	●	●	●	●	●	●	●	●	●
38 / (8)	8				●	●	●	●	●	●	●	●	●

Ordering Code (example):

2202.7G

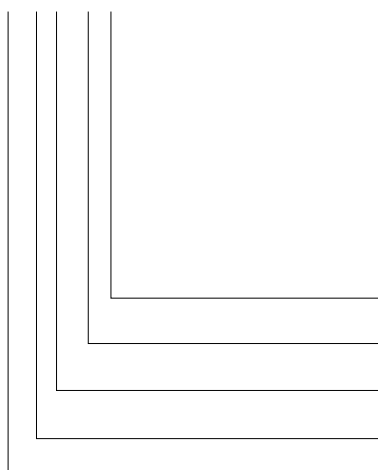

Length: l
100 mm
Diameter: d₂
32 mm
Type:
light
Execution:
blank
Punch:
without ejector pin

Order Code character
= (G)
Order No
= (7)
Order No
= (2)
Order No
= (0)
= 22

Material:

HSS
Hardness 62 ± 2 HRC

Execution:

Shaft fine ground.
Special dimensions on request.

BALL-LOCK PUNCH, STEPPED, ROUND, LIGHT DUTY



2212.

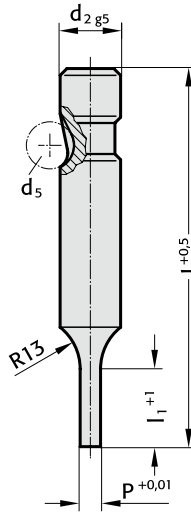

2212. Ball-Lock punch, stepped, round, light duty

d ₂ / Order No	d ₅	P	l ₁ / Order No	l (Order Code character)	63 (C)	71 (D)	80 (E)	90 (F)	100 (G)
6 / (1)	6	1,6 - 5,9	13(1)		●	●	●	●	●
10 / (2)	8	1,6 - 9,9	13(1) 19(2)		●	●	●	●	●
13 / (3)	8	5 - 12,9	13(1) 19(2)		●	●	●	●	●
16 / (4)	8	8 - 15,9	13(1) 19(2) 25(3)		●	●	●	●	●
20 / (5)	8	12 - 19,9	13(1) 19(2) 25(3)		●	●	●	●	●
25 / (6)	8	16 - 24,9	13(1) 19(2) 25(3)		●	●	●	●	●
32 / (7)	8	24 - 31,9	13(1) 19(2) 25(3)			●	●	●	●
38 / (8)	8	30 - 37,9	19(2) 25(3) 30(4)				●	●	●

l₁=10 where P < 2.20

Material:

HSS
Hardness 62 ± 2 HRC

Execution:

Shaft and punch diameter fine ground.
Special dimensions on request.

Ordering Code (example):

2212.7G2.2450

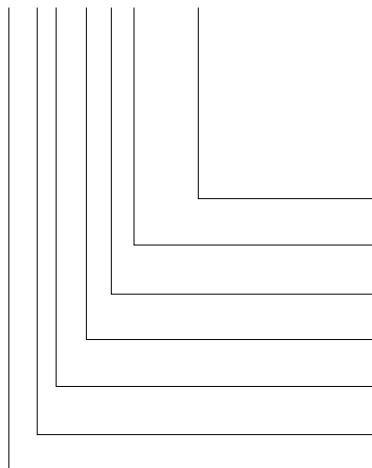

Shape: round

P = Ø 24,5 mm

Punch cutting length: l₁
19 mm

Length: l
100 mm

Diameter: d₂
32 mm

Type:
light

Execution:
round

Punch:
without ejector pin

= 2450

Order No
= (2)

Order Code character
= (G)

Order No
= (7)

Order No
= (2)

Order No
= (1)

= 22

BALL-LOCK PUNCH, STEPPED, SQUARE, LIGHT DUTY

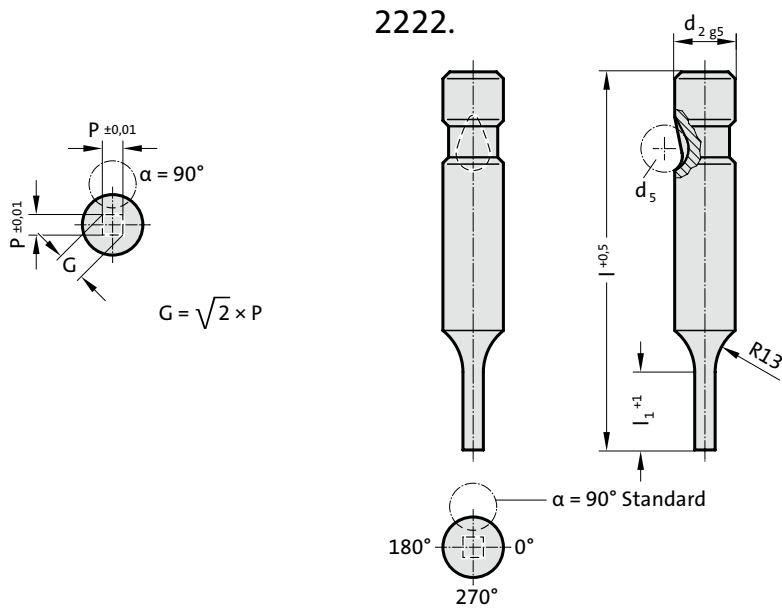

2222. Ball-Lock punch, stepped, square, light duty

d ₂ / Order No	d ₅	P _{min}	G _{max}	l ₁ / Order No	l (Order Code character)	63 (C)	71 (D)	80 (E)	90 (F)	100 (G)
6 / (1)	6	1.6	5.9	13(1)		●	●	●	●	●
10 / (2)	8	1.6	9.9	13(1) 19(2)		●	●	●	●	●
13 / (3)	8	4.5	12.9	13(1) 19(2)		●	●	●	●	●
16 / (4)	8	6	15.9	13(1) 19(2) 25(3)		●	●	●	●	●
20 / (5)	8	8	19.9	13(1) 19(2) 25(3)		●	●	●	●	●
25 / (6)	8	10	24.9	13(1) 19(2) 25(3)		●	●	●	●	●
32 / (7)	8	12.5	31.9	13(1) 19(2) 25(3)			●	●	●	●
38 / (8)	8	14	37.9	19(2) 25(3) 30(4)				●	●	●

l₁=10 where P < 2.20

Ordering Code (example):

2222.2E1.0650.A

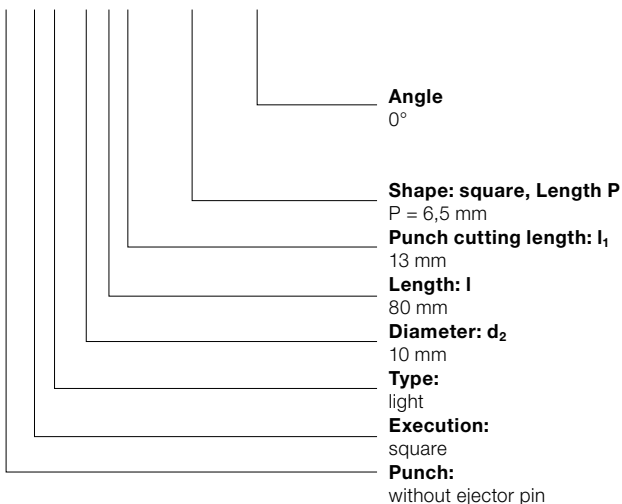

Order Code character
= (A)

= 0650

Order No
= (1)

Order Code character
= (E)

Order No
= (2)

Order No
= (2)

Order No
= (2)

= 22

Material:

HSS

Hardness 62 ± 2 HRC

Execution:

Shaft and punch shape fine ground.
Special dimensions on request.

Note:

With kerf ≤ 0.04 mm, FIBRO rounds off sharp edges if the punch and piercing die bush are ordered together. This reduces the fitting time and the risk of an edge break during operation.

BALL-LOCK PUNCH, STEPPED, RECTANGULAR, LIGHT DUTY



2232.

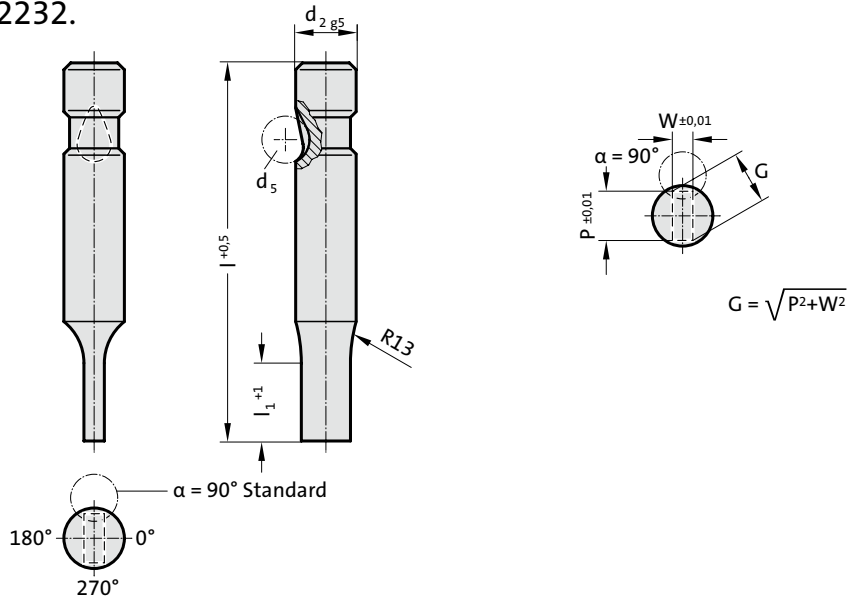

2232. Ball-Lock punch, stepped, rectangular, light duty

d ₂ / Order No	d ₅	W _{min}	G _{max}	l ₁ / Order No	l (Order Code character)	63 (C)	71 (D)	80 (E)	90 (F)	100 (G)
6 / (1)	6	1.6	5.9	13(1)		●	●	●	●	●
10 / (2)	8	1.6	9.9	13(1) 19(2)		●	●	●	●	●
13 / (3)	8	4.5	12.9	13(1) 19(2)		●	●	●	●	●
16 / (4)	8	6	15.9	13(1) 19(2) 25(3)		●	●	●	●	●
20 / (5)	8	8	19.9	13(1) 19(2) 25(3)		●	●	●	●	●
25 / (6)	8	10	24.9	13(1) 19(2) 25(3)		●	●	●	●	●
32 / (7)	8	12.5	31.9	13(1) 19(2) 25(3)			●	●	●	●
38 / (8)	8	14	37.9	19(2) 25(3) 30(4)				●	●	●

l₁=10 where W < 2.20

Material:

HSS
Hardness 62 ± 2 HRC

Execution:

Shaft and punch shape fine ground.
Special dimensions on request.

Note:

With kerf ≤ 0.04 mm, FIBRO rounds off sharp edges if the punch and piercing die bush are ordered together. This reduces the fitting time and the risk of an edge break during operation.

Ordering Code (example):

2232.2F1.0650.0450.B

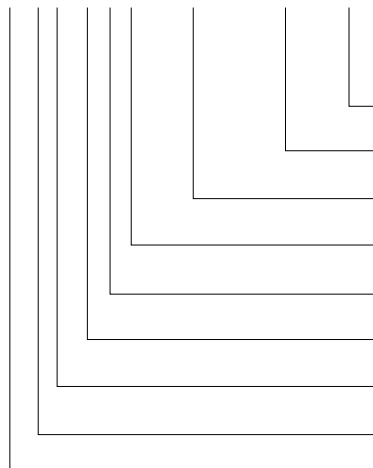

Angle 90°	Order Code character = (B)
Shape: rectangular, Width W W = 4,5 mm	= 0450
Shape: rectangular, Length P P = 6,5 mm	= 0650
Punch cutting length: l₁ 13 mm	Order No = (1)
Length: l 90 mm	Order Code character = (F)
Diameter: d₂ 10 mm	Order No = (2)
Type: light	Order No = (2)
Execution: rectangular	Order No = (3)
Punch: without ejector pin	= 22

BALL-LOCK PUNCH, STEPPED, SLOT, LIGHT DUTY

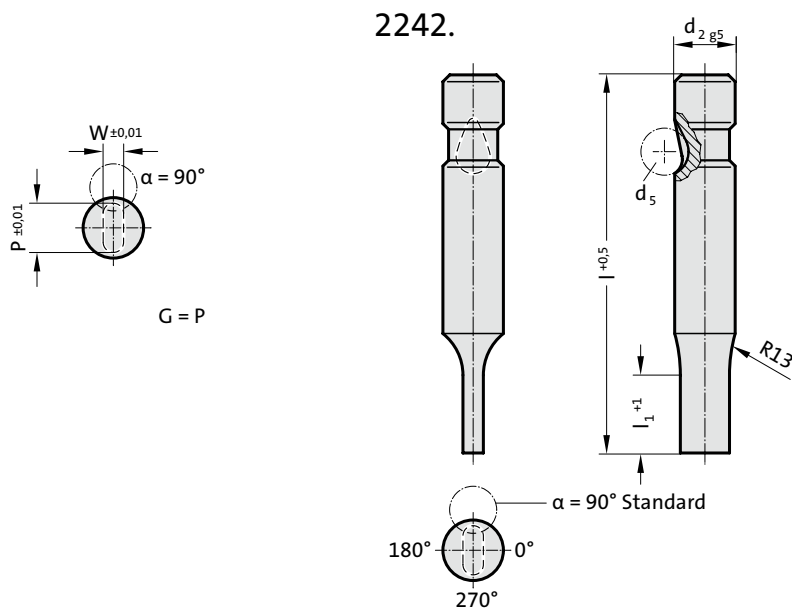

2242. Ball-Lock punch, stepped, slot, light duty

d ₂ / Order No	d ₅	W _{min}	G _{max}	l ₁ / Order No	l (Order Code character)	63	71	80	90	100
						(C)	(D)	(E)	(F)	(G)
6 / (1)	6	1.6	5.9	13(1)		●	●	●	●	●
10 / (2)	8	1.6	9.9	13(1) 19(2)		●	●	●	●	●
13 / (3)	8	4.5	12.9	13(1) 19(2)		●	●	●	●	●
16 / (4)	8	6	15.9	13(1) 19(2) 25(3)		●	●	●	●	●
20 / (5)	8	8	19.9	13(1) 19(2) 25(3)		●	●	●	●	●
25 / (6)	8	10	24.9	13(1) 19(2) 25(3)		●	●	●	●	●
32 / (7)	8	12.5	31.9	13(1) 19(2) 25(3)			●	●	●	●
38 / (8)	8	14	37.9	19(2) 25(3) 30(4)				●	●	●

l₁=10 where W < 2.20

Ordering Code (example):

2242.2F1.0650.0450.B

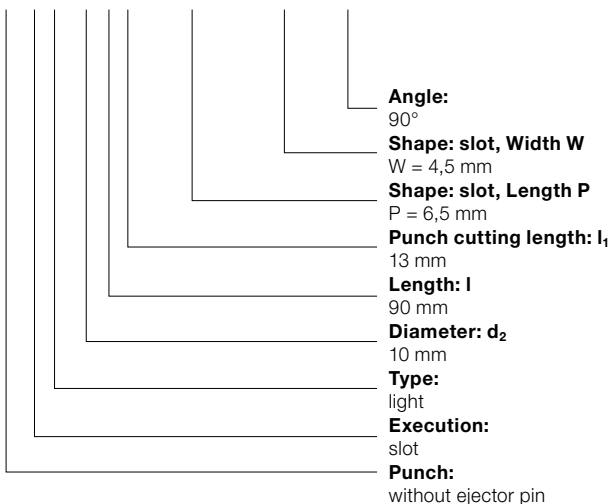

Order Code character
= (B)

= 0450

= 0650

Order No
= (1)

Order Code character
= (F)

Order No
= (2)

Order No
= (2)

Order No
= (4)

= 22

Material:

HSS

Hardness 62 ± 2 HRC

Execution:

Shaft and punch shape fine ground.
Special dimensions on request.

BALL-LOCK PUNCH, STEPPED, RECTANGLE WITH RADIUSSED CORNERS, LIGHT DUTY



2252.

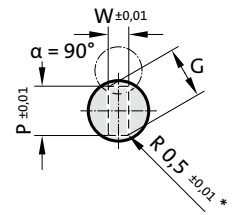
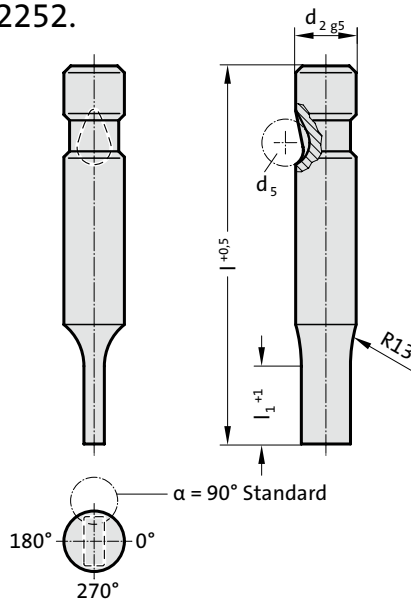

$$G = \sqrt{(P-1.0)^2 + (W-1.0)^2} + 1$$

2252. Ball-Lock punch, stepped, rectangle with radiused corners, light duty

d ₂ / Order No	d ₅	W _{min}	G _{max}	l ₁ / Order No	l (Order Code character)	63 (C)	71 (D)	80 (E)	90 (F)	100 (G)
6 / (1)	6	1.6	5.9	13(1)		●	●	●	●	●
10 / (2)	8	1.6	9.9	13(1) 19(2)		●	●	●	●	●
13 / (3)	8	4.5	12.9	13(1) 19(2)		●	●	●	●	●
16 / (4)	8	6	15.9	13(1) 19(2) 25(3)		●	●	●	●	●
20 / (5)	8	8	19.9	13(1) 19(2) 25(3)		●	●	●	●	●
25 / (6)	8	10	24.9	13(1) 19(2) 25(3)		●	●	●	●	●
32 / (7)	8	12.5	31.9	13(1) 19(2) 25(3)			●	●	●	●
38 / (8)	8	14	37.9	19(2) 25(3) 30(4)				●	●	●

l₁=10 where W < 2.20

Material:

HSS

Hardness 62 ± 2 HRC

Execution:

Shaft and punch shape fine ground.

Special dimensions on request.

* For other radius options, see standardised special shapes.

Ordering Code (example):

2252.2F1.0650.0450.B

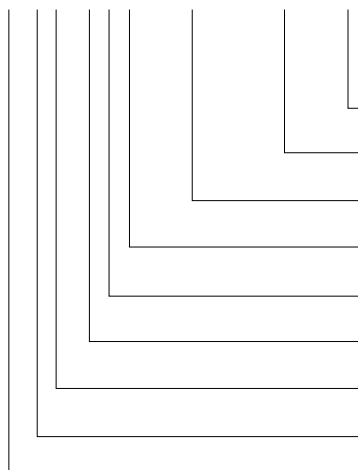

Angle:

90°

Shape: rectangle with radiused corners, Width W
W = 4,5 mm

Shape: rectangle with radiused corners, Length P
P = 6,5 mm

Punch cutting length: l₁
13 mm

Length: l
90 mm

Diameter: d₂
10 mm

Type:
light

Execution:
rectangle with radiused corners

Punch:
without ejector pin

Order Code character
= (B)

Order Code character
= 0450

Order Code character
= 0650

Order No
= (1)

Order Code character
= (F)

Order No
= (2)

Order No
= (2)

Order No
= (5)

Order No
= 22

BALL-LOCK PUNCH, BLANK, WITH EJECTOR PIN, LIGHT DUTY

2702.

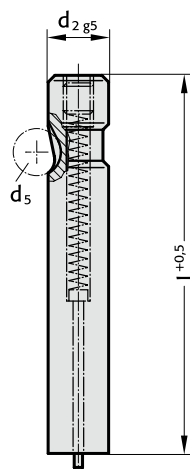

2702. Ball-Lock punch, blank, with ejector pin, light duty

d ₂ / Order No	d ₅	l / (Order Code character)	63 (C)	71 (D)	80 (E)	90 (F)	100 (G)
6 / (1)	6		●	●	●	●	●
10 / (2)	8		●	●	●	●	●
13 / (3)	8		●	●	●	●	●
16 / (4)	8		●	●	●	●	●
20 / (5)	8		●	●	●	●	●
25 / (6)	8		●	●	●	●	●
32 / (7)	8			●	●	●	●
38 / (8)	8				●	●	●

Ordering Code (example):

2702.7G

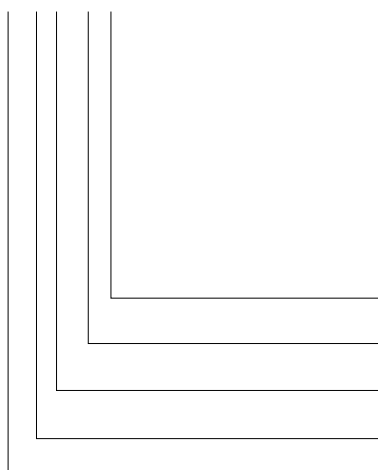

Length: l
100 mm
Diameter: d₂
32 mm
Type:
light
Execution:
blank
Punch:
with ejector pin

Order Code character
= (G)
Order No
= (7)
Order No
= (2)
Order No
= (0)
= 27

Material:

HSS
Hardness 62 ± 2 HRC

Execution:

Shaft fine ground.
Special dimensions on request.

BALL-LOCK PUNCH, STEPPED, ROUND, WITH EJECTOR PIN, LIGHT DUTY



2712.

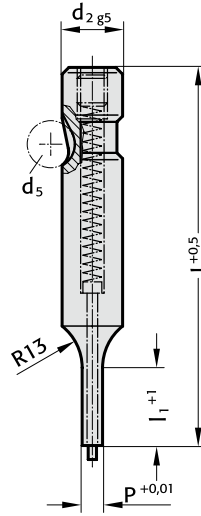

2712. Ball-Lock punch, stepped, round, with ejector pin, light duty

d ₂ / Order No	d ₅	P	l ₁ / Order No	l (Order Code character)	63 (C)	71 (D)	80 (E)	90 (F)	100 (G)
6 / (1)	6	2,5 - 5,9	13(1)		●	●	●	●	●
10 / (2)	8	5 - 9,9	13(1) 19(2)		●	●	●	●	●
13 / (3)	8	6 - 12,9	13(1) 19(2)		●	●	●	●	●
16 / (4)	8	8 - 15,9	13(1) 19(2) 25(3)		●	●	●	●	●
20 / (5)	8	10 - 19,9	13(1) 19(2) 25(3)		●	●	●	●	●
25 / (6)	8	12 - 24,9	13(1) 19(2) 25(3)		●	●	●	●	●
32 / (7)	8	16 - 31,9	13(1) 19(2) 25(3)			●	●	●	●
38 / (8)	8	19 - 37,9	19(2) 25(3) 30(4)				●	●	●

Material:

HSS
Hardness 62 ± 2 HRC

Execution:

Shaft and punch diameter fine ground.
Special dimensions on request.

Ordering Code (example):

2712.7G2.2450

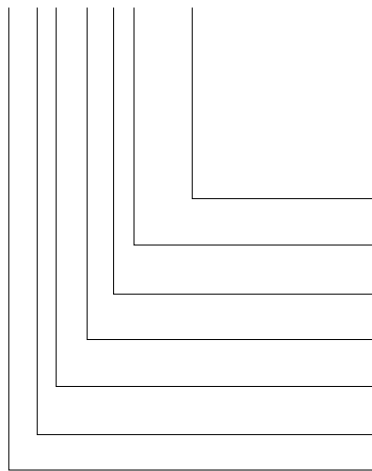

Shape: round

P = Ø 24,5 mm

Punch cutting length: l₁
19 mm

Length: l
100 mm

Diameter: d₂
32 mm

Type:
light

Execution:
round

Punch:
with ejector pin

= 2450

Order No
= (2)

Order Code character
= (G)

Order No
= (7)

Order No
= (2)

Order No
= (1)

= 27

BALL-LOCK PUNCH, STEPPED, SQUARE, WITH EJECTOR PIN, LIGHT DUTY

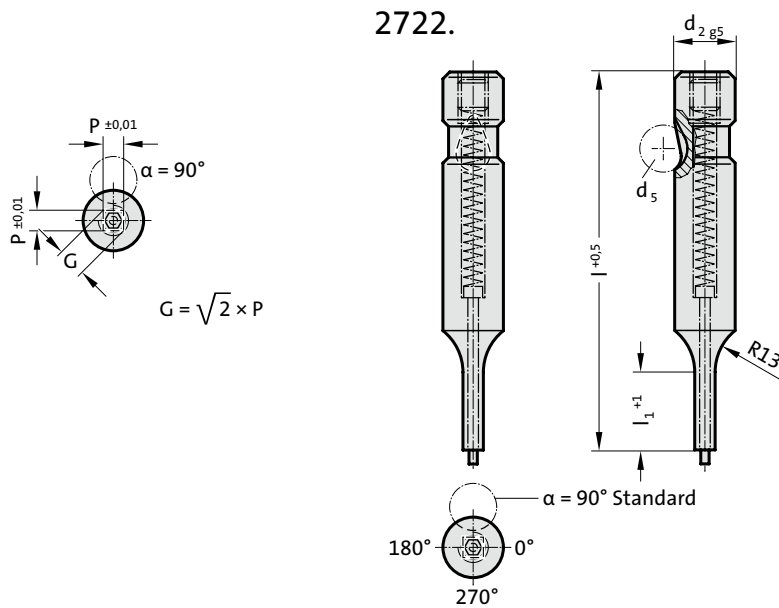

2722. Ball-Lock punch, stepped, square, with ejector pin, light duty

d ₂ / Order No	d ₅	P _{min}	G _{max}	l ₁ / Order No	l (Order Code character)	63	71	80	90	100
						(C)	(D)	(E)	(F)	(G)
6 / (1)	6	2.5	5.9	13(1)		●	●	●	●	●
10 / (2)	8	4	9.9	13(1) 19(2)		●	●	●	●	●
13 / (3)	8	6	12.9	13(1) 19(2)		●	●	●	●	●
16 / (4)	8	8	15.9	13(1) 19(2) 25(3)		●	●	●	●	●
20 / (5)	8	10	19.9	13(1) 19(2) 25(3)		●	●	●	●	●
25 / (6)	8	12	24.9	13(1) 19(2) 25(3)		●	●	●	●	●
32 / (7)	8	16	31.9	13(1) 19(2) 25(3)			●	●	●	●
38 / (8)	8	19	37.9	19(2) 25(3) 30(4)				●	●	●

Ordering Code (example):

2722.2E1.0650.A

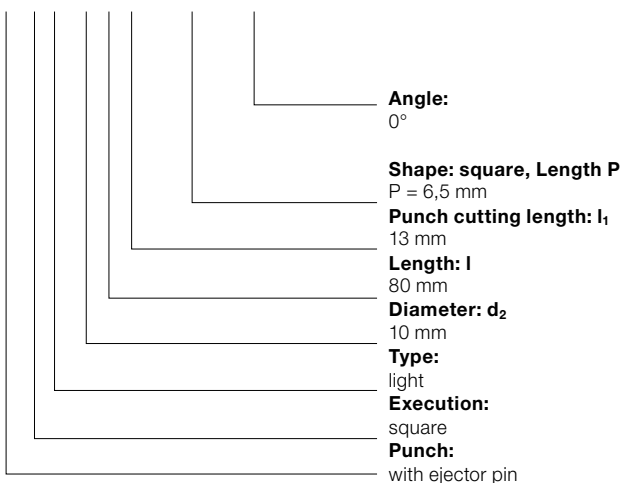

Order Code character
= (A)

= 0650

Order No
= (1)

Order Code character
= (E)

Order No
= (2)

Order No
= (2)

Order No
= (2)

= 27

Material:

HSS

Hardness 62 ± 2 HRC

Execution:

Shaft and punch shape fine ground.
Special dimensions on request.

Note:

With kerf ≤ 0.04 mm, FIBRO rounds off sharp edges if the punch and piercing die bush are ordered together. This reduces the fitting time and the risk of an edge break during operation.

BALL-LOCK PUNCH, STEPPED, RECTANGULAR, WITH EJECTOR PIN, LIGHT DUTY



2732.

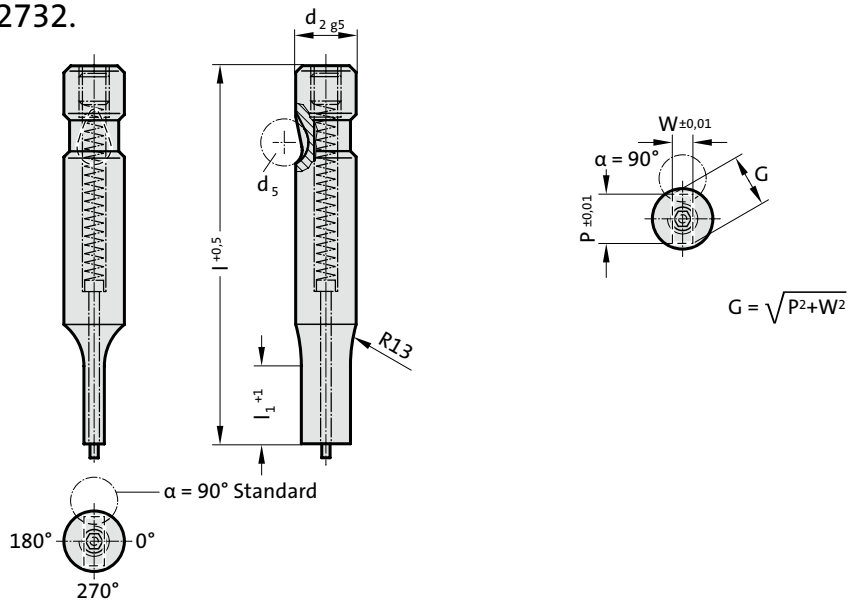

2732. Ball-Lock punch, stepped, rectangular, with ejector pin, light duty

d ₂ / Order No	d ₅	W _{min}	G _{max}	l ₁ / Order No	l (Order Code character)	63 (C)	71 (D)	80 (E)	90 (F)	100 (G)
6 / (1)	6	2.5	5.9	13(1)		●	●	●	●	●
10 / (2)	8	4	9.9	13(1) 19(2)		●	●	●	●	●
13 / (3)	8	6	12.9	13(1) 19(2)		●	●	●	●	●
16 / (4)	8	8	15.9	13(1) 19(2) 25(3)		●	●	●	●	●
20 / (5)	8	10	19.9	13(1) 19(2) 25(3)		●	●	●	●	●
25 / (6)	8	12	24.9	13(1) 19(2) 25(3)		●	●	●	●	●
32 / (7)	8	16	31.9	13(1) 19(2) 25(3)			●	●	●	●
38 / (8)	8	19	37.9	19(2) 25(3) 30(4)				●	●	●

Material:

HSS
Hardness 62 ± 2 HRC

Execution:

Shaft and punch shape fine ground.
Special dimensions on request.

Note:

With kerf ≤ 0.04 mm, FIBRO rounds off sharp edges if the punch and piercing die bush are ordered together. This reduces the fitting time and the risk of an edge break during operation.

Ordering Code (example):

2732.2F1.0650.0450.B

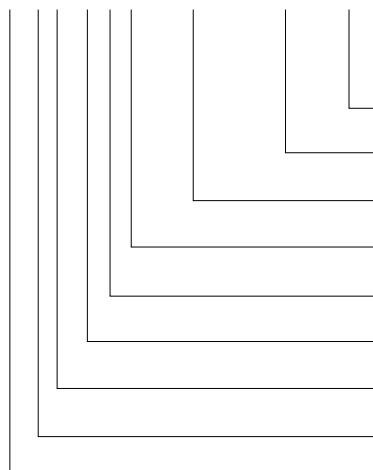

Angle: 90°
Shape: rectangular, Width W
W = 4,5 mm
Shape: rectangular, Length P
P = 6,5 mm
Punch cutting length: l₁
13 mm
Length: l
90 mm
Diameter: d₂
10 mm
Type: light
Execution: rectangular
Punch: with ejector pin

Order Code character
= (B)
= 0450
= 0650
Order No
= (1)
Order Code character
= (F)
Order No
= (2)
Order No
= (2)
Order No
= (3)
= 27

BALL-LOCK PUNCH, STEPPED, SLOT, WITH EJECTOR PIN, LIGHT DUTY

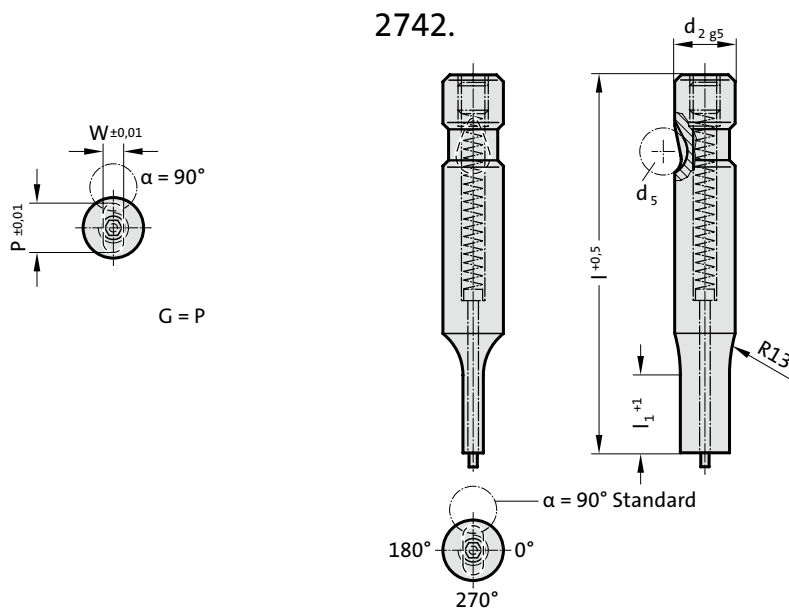

2742. Ball-Lock punch, stepped, slot, with ejector pin, light duty

d ₂ / Order No	d ₅	W _{min}	G _{max}	l ₁ / Order No	l (Order Code character)	63	71	80	90	100
						(C)	(D)	(E)	(F)	(G)
6 / (1)	6	2.5	5.9	13(1)		●	●	●	●	●
10 / (2)	8	4	9.9	13(1) 19(2)		●	●	●	●	●
13 / (3)	8	6	12.9	13(1) 19(2)		●	●	●	●	●
16 / (4)	8	8	15.9	13(1) 19(2) 25(3)		●	●	●	●	●
20 / (5)	8	10	19.9	13(1) 19(2) 25(3)		●	●	●	●	●
25 / (6)	8	12	24.9	13(1) 19(2) 25(3)		●	●	●	●	●
32 / (7)	8	16	31.9	13(1) 19(2) 25(3)			●	●	●	●
38 / (8)	8	19	37.9	19(2) 25(3) 30(4)				●	●	●

Ordering Code (example):

2742.2F1.0650.0450.B

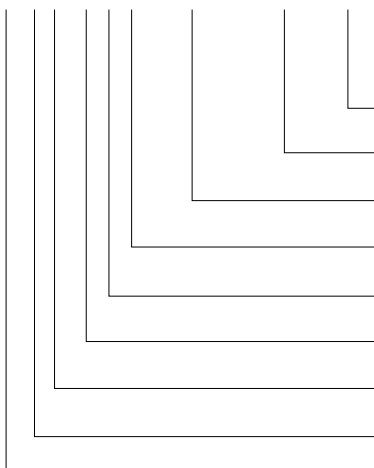

Angle:
90°
Shape: slot, Width W
W = 4,5 mm
Shape: slot, Length P
P = 6,5 mm
Punch cutting length: l₁
13 mm
Length: l
90 mm
Diameter: d₂
10 mm
Type:
light
Execution:
slot
Punch:
with ejector pin

Order Code character
= (B)
= 0450
= 0650
Order No
= (1)
Order Code character
= (F)
Order No
= (2)
Order No
= (2)
Order No
= (4)
= 27

Material:

HSS
Hardness 62 ± 2 HRC

Execution:

Shaft and punch shape fine ground.
Special dimensions on request.

BALL-LOCK PUNCH, STEPPED, RECTANGLE WITH RADIUSSED CORNERS, WITH EJECTOR PIN, LIGHT DUTY



2752.

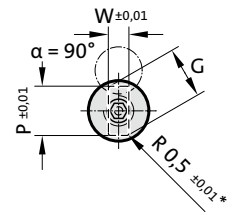
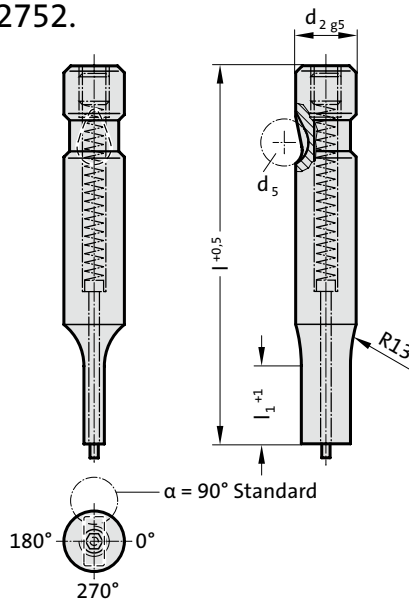

$$G = \sqrt{(P-1.0)^2 + (W-1.0)^2} + 1$$

2752. Ball-Lock punch, stepped, rectangle with radiussed corners, with ejector pin, light duty

d ₂ / Order No	d ₅	W _{min}	G _{max}	l ₁ / Order No	l (Order Code character)	63 (C)	71 (D)	80 (E)	90 (F)	100 (G)
6 / (1)	6	2.5	5.9	13(1)		●	●	●	●	●
10 / (2)	8	4	9.9	13(1) 19(2)		●	●	●	●	●
13 / (3)	8	6	12.9	13(1) 19(2)		●	●	●	●	●
16 / (4)	8	8	15.9	13(1) 19(2) 25(3)		●	●	●	●	●
20 / (5)	8	10	19.9	13(1) 19(2) 25(3)		●	●	●	●	●
25 / (6)	8	12	24.9	13(1) 19(2) 25(3)		●	●	●	●	●
32 / (7)	8	16	31.9	13(1) 19(2) 25(3)			●	●	●	●
38 / (8)	8	19	37.9	19(2) 25(3) 30(4)				●	●	●

Material:

HSS
Hardness 62 ± 2 HRC

Execution:

Shaft and punch shape fine ground.
Special dimensions on request.
* For other radius options, see standardised special shapes.

Ordering Code (example):

2752.2F1.0650.0450.B

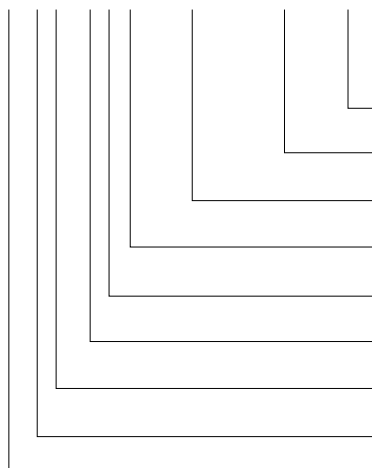

Angle: 90°
Shape: rectangle with radiussed corners, Width W = 4,5 mm
Shape: rectangle with radiussed corners, Length P = 6,5 mm
Punch cutting length: l₁ = 13 mm
Length: l = 90 mm
Diameter: d₂ = 10 mm
Type: light
Execution: rectangle with radiussed corners
Punch: with ejector pin

Order Code character = (B)
Order No = 0450
Order Code character = (F)
Order No = 0650
Order Code character = (1)
Order No = (1)
Order Code character = (F)
Order No = (2)
Order Code character = (2)
Order No = (2)
Order Code character = (5)
Order No = (27)

BALL-LOCK PUNCH, PUNCH LARGER THAN SHAFT, BLANK, LIGHT DUTY

2204.

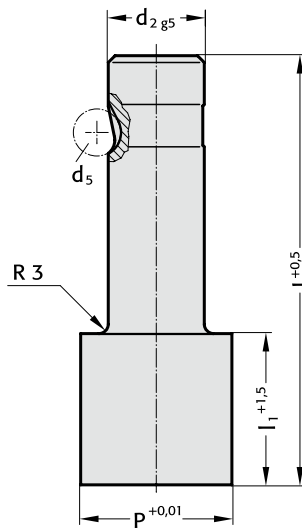
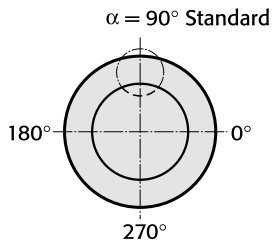

2204. Ball-Lock punch, punch larger than shaft, blank, light duty

d ₂ / Order No	d ₅	P	l ₁ / Order No	l (Order Code character)	80 (E)	90 (F)	100 (G)
13 / (3)	8	32	19 / (2) 30 / (4)		●	●	●
16 / (4)	8	38	19 / (2) 30 / (4)		●	●	●
20 / (5)	8	40	19 / (2) 30 / (4)		●	●	●
25 / (6)	8	44	19 / (2) 30 / (4)		●	●	●
32 / (7)	8	50	19 / (2) 30 / (4)		●	●	●

Ordering Code (example):

2204.4F4.3800

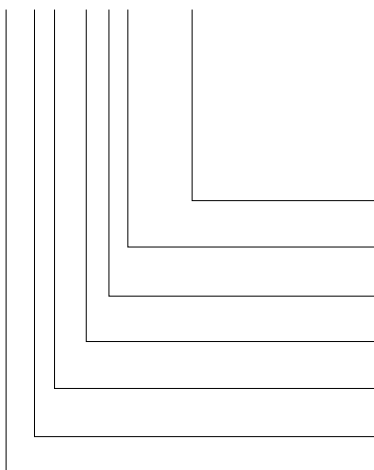

Shape: round

P = Ø 38 mm

Punch cutting length: l₁
30 mm

Length: l
90 mm

Diameter: d₂
16 mm

Type:
punch larger, light

Execution:
blank

Punch:
without ejector pin

= 3800

Order No
= (4)

Order Code character
= (F)

Order No
= (4)

Order No
= (4)

Order No
= (0)

= 22

Material:

HSS

Hardness 62 ± 2 HRC

Execution:

Shaft and punch diameter fine ground.

Special dimensions on request.

BALL-LOCK PUNCH, PUNCH LARGER THAN SHAFT, ROUND, LIGHT DUTY



2214.

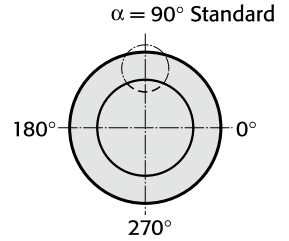
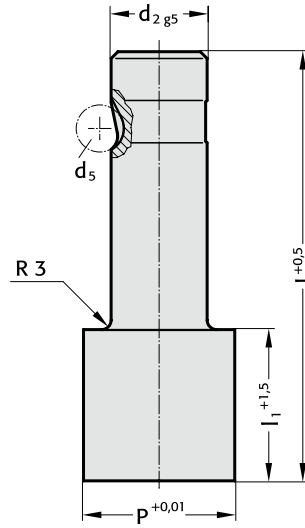

2214. Ball-Lock punch, punch larger than shaft, round, light duty

d ₂ / Order No	d ₅	P	l ₁ / Order No	l (Order Code character)	80 (E)	90 (F)	100 (G)
13 / (3)	8	13,1 - 32	19(2) 30(4)		●	●	●
16 / (4)	8	16,1 - 38	19(2) 30(4)		●	●	●
20 / (5)	8	20,1 - 40	19(2) 30(4)		●	●	●
25 / (6)	8	25,1 - 44	19(2) 30(4)		●	●	●
32 / (7)	8	32,1 - 50	19(2) 30(4)		●	●	●

Material:

HSS
Hardness 62 ± 2 HRC

Execution:

Shaft and punch diameter fine ground.
Special dimensions on request.

Ordering Code (example):

2214.7G2.3820

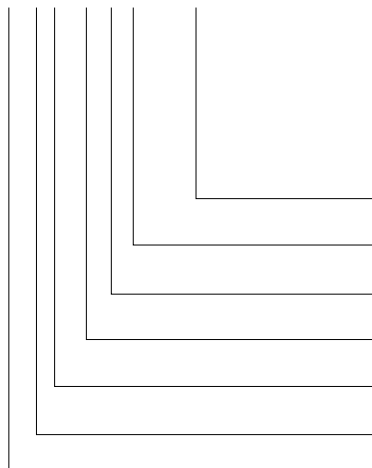

Shape: round

P = Ø 38,2 mm

Punch cutting length: l₁
19 mm

Length: l
100 mm

Diameter: d₂
32 mm

Type:
punch larger, light

Execution:
round

Punch:
without ejector pin

= 3820

Order No
= (2)

Order Code character
= (G)

Order No
= (7)

Order No
= (4)

Order No
= (1)

= 22

BALL-LOCK PUNCH, PUNCH LARGER THAN SHAFT, SQUARE, LIGHT DUTY

2224.

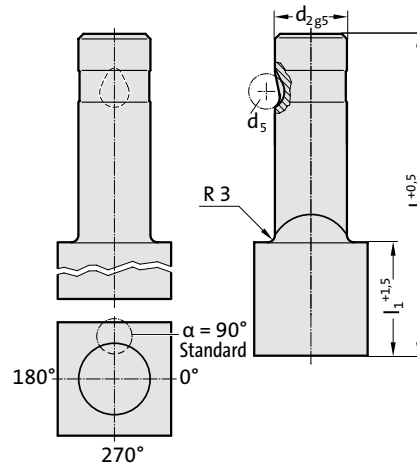
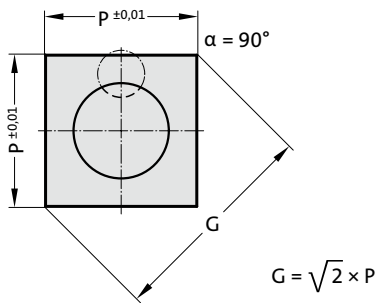

2224. Ball-Lock punch, punch larger than shaft, square, light duty

d ₂ / Order No	d ₅	P _{min}	G _{max}	l ₁ / Order No	I (Order Code character)	80	90	100
						(E)	(F)	(G)
13 / (3)	8	9.19	32	19(2) 30(4)		●	●	●
16 / (4)	8	11.31	38	19(2) 30(4)		●	●	●
20 / (5)	8	14.14	40	19(2) 30(4)		●	●	●
25 / (6)	8	17.68	44	19(2) 30(4)		●	●	●
32 / (7)	8	22.63	50	19(2) 30(4)		●	●	●

Ordering Code (example):

2224.7F2.3535.A

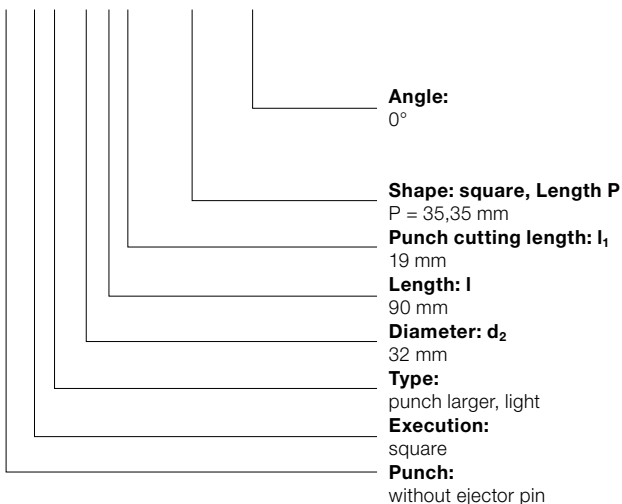

Order Code character
= (A)

= 3535

Order No
= (2)

Order Code character
= (F)

Order No
= (7)

Order No
= (4)

Order No
= (2)

= 22

Material:

HSS

Hardness 62 ± 2 HRC

Execution:

Shaft and punch shape fine ground.
Special dimensions on request.

Note:

With kerf ≤ 0.04 mm, FIBRO rounds off sharp edges if the punch and piercing die bush are ordered together. This reduces the fitting time and the risk of an edge break during operation.

BALL-LOCK PUNCH, PUNCH LARGER THAN SHAFT, RECTANGULAR, LIGHT DUTY



2234.

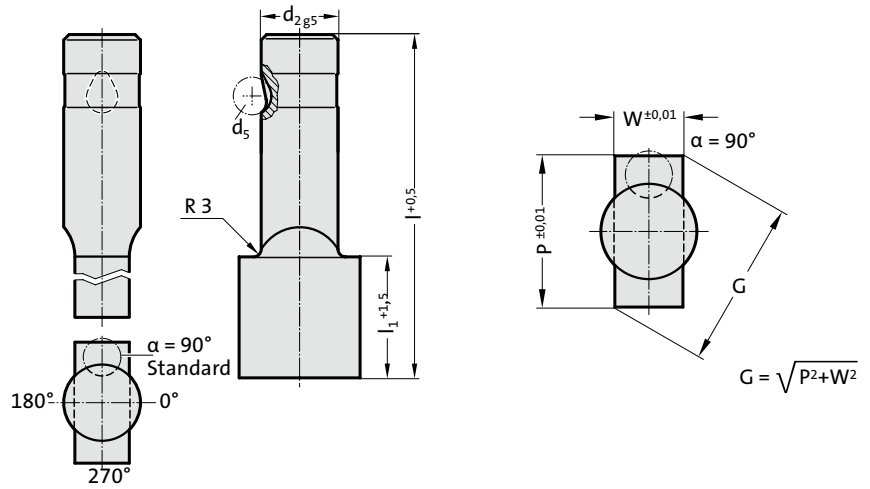

2234. Ball-Lock punch, punch larger than shaft, rectangular, light duty

d ₂ / Order No	d ₅	W _{min}	G _{max}	l ₁ / Order No	l (Order Code character)	80	90	100
						(E)	(F)	(G)
13 / (3)	8	5	32	19(2) 30(4)		●	●	●
16 / (4)	8	6.5	38	19(2) 30(4)		●	●	●
20 / (5)	8	8	40	19(2) 30(4)		●	●	●
25 / (6)	8	10	44	19(2) 30(4)		●	●	●
32 / (7)	8	11.5	50	19(2) 30(4)		●	●	●

Material:

HSS
Hardness 62 ± 2 HRC

Execution:

Shaft and punch shape fine ground.
Special dimensions on request.

Note:

With kerf ≤ 0.04 mm, FIBRO rounds off sharp edges if the punch and piercing die bush are ordered together. This reduces the fitting time and the risk of an edge break during operation.

Ordering Code (example):

2234.7F2.3820.1150.B

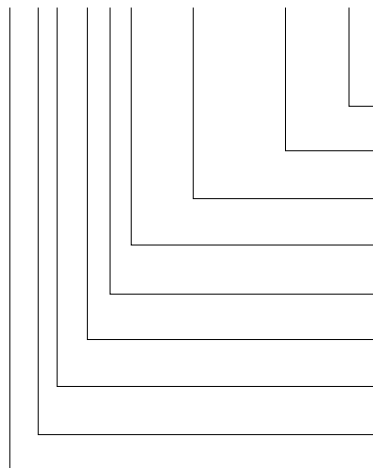

Angle:

90°

Shape: rectangular, Width W

W = 11,5 mm

Shape: rectangular, Length P

P = 38,2 mm

Punch cutting length: l₁

19 mm

Length: l

90 mm

Diameter: d₂

32 mm

Type:

punch larger, light

Execution:

rectangular

Punch:

without ejector pin

Order Code character

= (B)

= 1150

= 3820

Order No

= (2)

Order Code character

= (F)

Order No

= (7)

Order No

= (4)

Order No

= (3)

= 22

BALL-LOCK PUNCH, PUNCH LARGER THAN SHAFT, SLOT, LIGHT DUTY

2244.

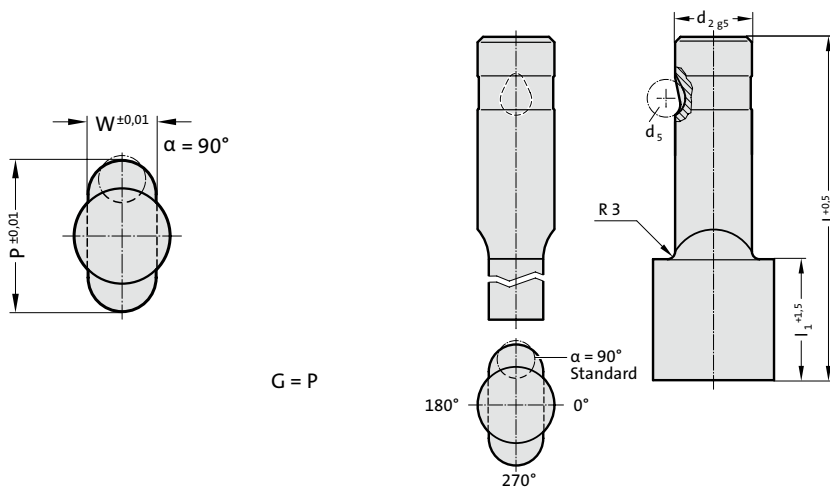

2244. Ball-Lock punch, punch larger than shaft, slot, light duty

d ₂ / Order No	d ₅	W _{min}	G _{max}	l ₁ / Order No	l (Order Code character)	80 (E)	90 (F)	100 (G)
13 / (3)	8	5	32	19(2) 30(4)		●	●	●
16 / (4)	8	6.5	38	19(2) 30(4)		●	●	●
20 / (5)	8	8	40	19(2) 30(4)		●	●	●
25 / (6)	8	10	44	19(2) 30(4)		●	●	●
32 / (7)	8	11.5	50	19(2) 30(4)		●	●	●

Ordering Code (example):

2244.4F2.3720.1150.B

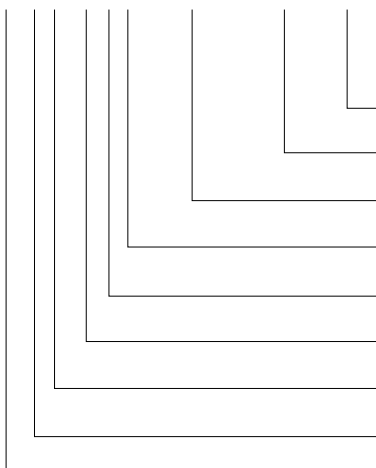

Angle:
90°
Shape: slot, Width W
W = 11,5 mm
Shape: slot, Length P
P = 37,2 mm
Punch cutting length: l₁
19 mm
Length: l
90 mm
Diameter: d₂
16 mm
Type:
punch larger, light
Execution:
slot
Punch:
without ejector pin

Order Code character
= (B)
= 1150
= 3720
Order No
= (2)
Order Code character
= (F)
Order No
= (4)
Order No
= (4)
Order No
= (4)

Material:

HSS
Hardness 62 ± 2 HRC

Execution:

Shaft and punch shape fine ground.
Special dimensions on request.

BALL-LOCK PUNCH, PUNCH LARGER THAN SHAFT, RECTANGLE WITH RADIUSSED CORNERS, LIGHT DUTY



2254.

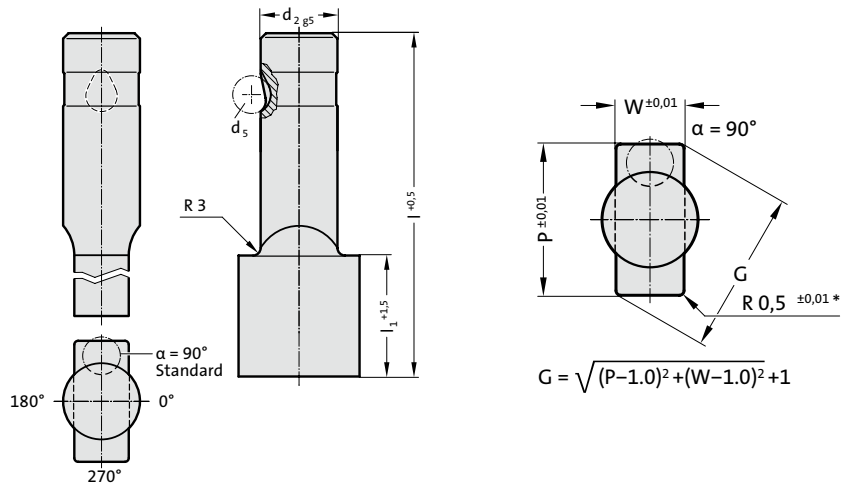

2254. Ball-Lock punch, punch larger than shaft, rectangle with radiussed corners, light duty

d ₂ / Order No	d ₅	W _{min}	G _{max}	l ₁ / Order No	l (Order Code character)	80 (E)	90 (F)	100 (G)
13 / (3)	8	5	32	19(2) 30(4)		●	●	●
16 / (4)	8	6.5	38	19(2) 30(4)		●	●	●
20 / (5)	8	8	40	19(2) 30(4)		●	●	●
25 / (6)	8	10	44	19(2) 30(4)		●	●	●
32 / (7)	8	11.5	50	19(2) 30(4)		●	●	●

Material:

HSS

Hardness 62 ± 2 HRC

Execution:

Shaft and punch shape fine ground.

Special dimensions on request.

* For other radius options, see standardised special shapes.

Ordering Code (example):

2254.7F2.3720.1150.B

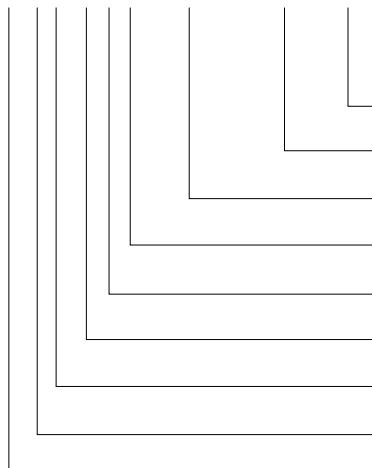

Angle:

90°

Shape: rectangle with radiused corners, Width W
W = 11,5 mm

Shape: rectangle with radiused corners, Length P
P = 37,2 mm

Punch cutting length: l₁
19 mm

Length: l

90 mm

Diameter: d₂

32 mm

Type:

punch larger, light

Execution:
rectangle with radiused corners

Punch:

without ejector pin

Order Code character
= (B)

Order Code character
= (F)

Order Code character
= (2)

Order Code character
= (F)

Order Code character
= (7)

Order Code character
= (4)

Order Code character
= (5)

Order Code character
= 22

BALL-LOCK PUNCH, PUNCH LARGER THAN SHAFT, BLANK, WITH EJECTOR PIN, LIGHT DUTY

2704.

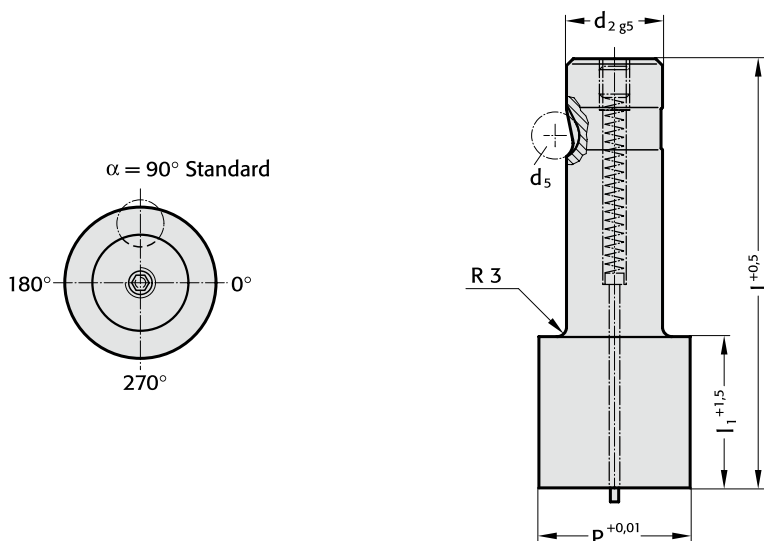

2704. Ball-Lock punch, punch larger than shaft, blank, with ejector pin, light duty

d ₂ / Order No	d ₅	P	l ₁ / Order No	l (Order Code character)	80 (E)	90 (F)	100 (G)
13 / (3)	8	32	19(2) 30(4)		●	●	●
16 / (4)	8	38	19(2) 30(4)		●	●	●
20 / (5)	8	40	19(2) 30(4)		●	●	●
25 / (6)	8	44	19(2) 30(4)		●	●	●
32 / (7)	8	50	19(2) 30(4)		●	●	●

Ordering Code (example):

2704.4F4.3800

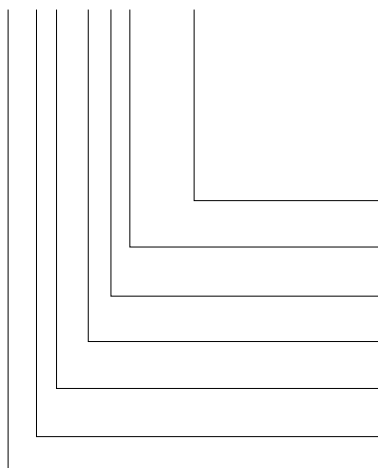

Shape: round
 P = Ø 38 mm = 3800
Punch cutting length: l₁
 30 mm = (4)
Order Code character
 = (F)
Order No
 = (4)
Order No
 = (4)
Order No
 = (0)

Material:

HSS
 Hardness 62 ± 2 HRC

Execution:

Shaft and punch diameter fine ground.
 Special dimensions on request.

BALL-LOCK PUNCH, PUNCH LARGER THAN SHAFT, ROUND, WITH EJECTOR PIN, LIGHT DUTY



2714.

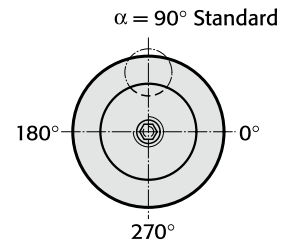
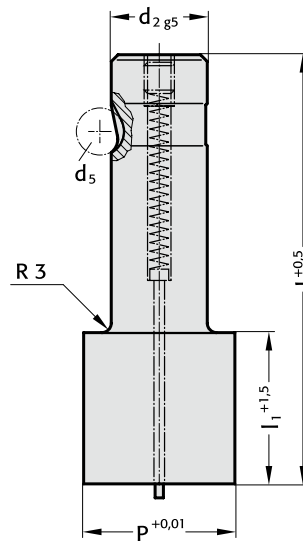

2714. Ball-Lock punch, punch larger than shaft, round, with ejector pin, light duty

d ₂ / Order No	d ₅	P	l ₁ / Order No	l (Order Code character)	80 (E)	90 (F)	100 (G)
13 / (3)	8	13,1 - 32	19(2) 30(4)		●	●	●
16 / (4)	8	16,1 - 38	19(2) 30(4)		●	●	●
20 / (5)	8	20,1 - 40	19(2) 30(4)		●	●	●
25 / (6)	8	25,1 - 44	19(2) 30(4)		●	●	●
32 / (7)	8	32,1 - 50	19(2) 30(4)		●	●	●

Material:

HSS
Hardness 62 ± 2 HRC

Execution:

Shaft and punch diameter fine ground.
Special dimensions on request.

Ordering Code (example):

2714.7G2.4250

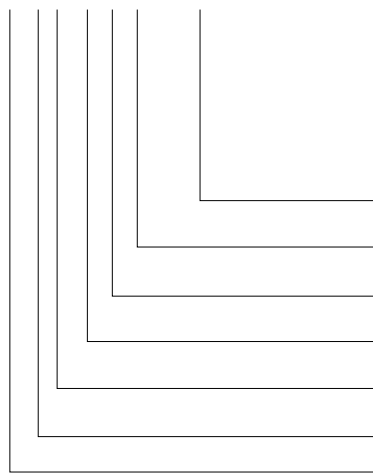

Shape: round

P = Ø 42,5 mm

Punch cutting length: l₁
19 mm

Length: l
100 mm

Diameter: d₂
32 mm

Type:
punch larger, light

Execution:

round

Punch:
with ejector pin

= 4250

Order No

= (2)

Order Code character

= (G)

Order No

= (7)

Order No

= (4)

Order No

= (1)

= 27

BALL-LOCK PUNCH, PUNCH LARGER THAN SHAFT, SQUARE, WITH EJECTOR PIN, LIGHT DUTY

2724.

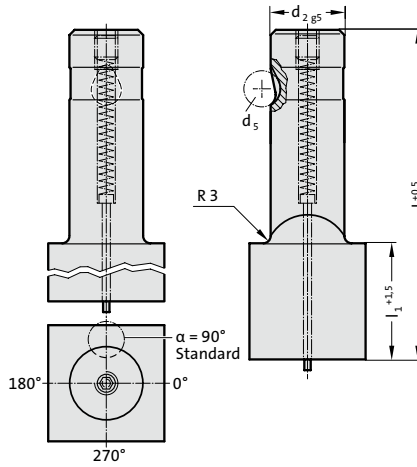
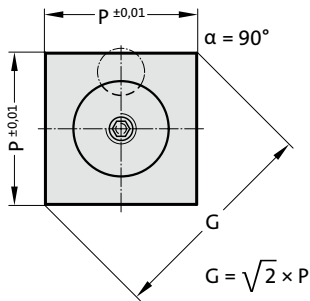

2724. Ball-Lock punch, punch larger than shaft, square, with ejector pin, light duty

d ₂ / Order No	d ₅	P _{min}	G _{max}	l ₁ / Order No	l (Order Code character)	80 (E)	90 (F)	100 (G)
13 / (3)	8	9.19	32	19(2) 30(4)		●	●	●
16 / (4)	8	11.31	38	19(2) 30(4)		●	●	●
20 / (5)	8	14.14	40	19(2) 30(4)		●	●	●
25 / (6)	8	17.68	44	19(2) 30(4)		●	●	●
32 / (7)	8	22.63	50	19(2) 30(4)		●	●	●

Ordering Code (example):

2724.5E2.2828.A

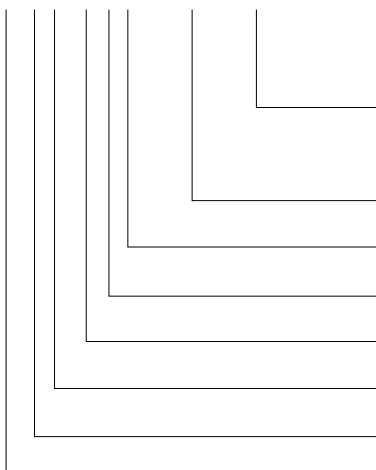

Angle:
0°

Shape: square, Length P
P = 28,28 mm

Punch cutting length: l₁
19 mm

Length: l
80 mm

Diameter: d₂
20 mm

Type:
punch larger, light

Execution:
square

Punch:
with ejector pin

Order Code character
= (A)

= 2828

Order No
= (2)

Order Code character
= (E)

Order No
= (5)

Order No
= (4)

Order No
= (2)

= 27

Material:

HSS

Hardness 62 ± 2 HRC

Execution:

Shaft and punch shape fine ground.
Special dimensions on request.

Note:

With kerf ≤ 0.04 mm, FIBRO rounds off sharp edges if the punch and piercing die bush are ordered together. This reduces the fitting time and the risk of an edge break during operation.

BALL-LOCK PUNCH, PUNCH LARGER THAN SHAFT, RECTANGULAR, WITH EJECTOR PIN, LIGHT DUTY



2734.

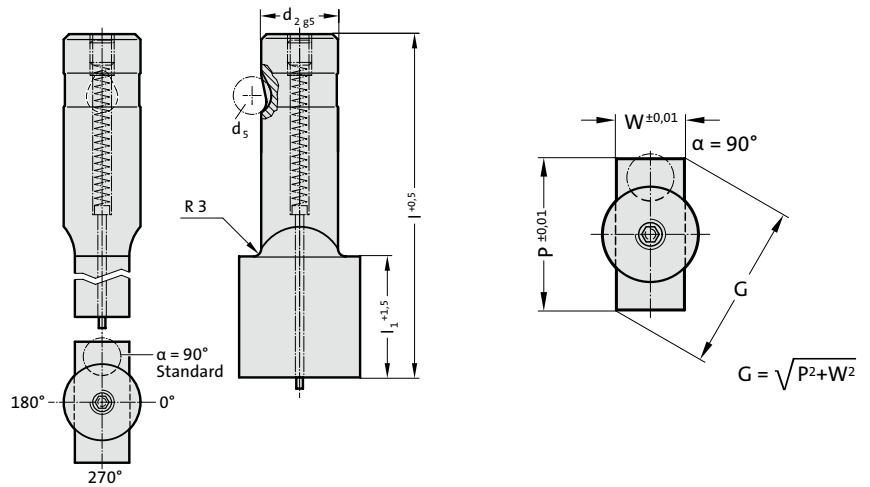

2734. Ball-Lock punch, punch larger than shaft, rectangular, with ejector pin, light duty

d_2 / Order No	d_5	W_{min}	G_{max}	l_1 / Order No	l (Order Code character)	80 (E)	90 (F)	100 (G)
13 / (3)	8	5	32	19(2) 30(4)		●	●	●
16 / (4)	8	6.5	38	19(2) 30(4)		●	●	●
20 / (5)	8	8	40	19(2) 30(4)		●	●	●
25 / (6)	8	10	44	19(2) 30(4)		●	●	●
32 / (7)	8	11.5	50	19(2) 30(4)		●	●	●

Material:

HSS
Hardness 62 ± 2 HRC

Execution:

Shaft and punch shape fine ground.
Special dimensions on request.

Note:

With kerf ≤ 0.04 mm, FIBRO rounds off sharp edges if the punch and piercing die bush are ordered together. This reduces the fitting time and the risk of an edge break during operation.

Ordering Code (example):

2734.7F2.3820.1150.B

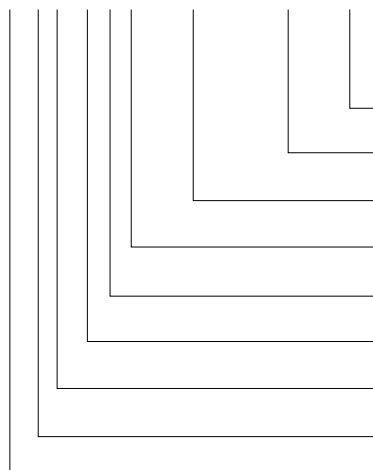

Angle:

90°

Shape: rectangular, Width W

W = 11,5 mm

Shape: rectangular, Length P

P = 38,2 mm

Punch cutting length: l_1

19 mm

Length: l

90 mm

Diameter: d_2

32 mm

Type:

punch larger, light

Execution:

rectangular

Punch:

with ejector pin

Order Code character

= (B)

= 1150

= 3820

Order No

= (2)

Order Code character

= (F)

Order No

= (7)

Order No

= (4)

Order No

= (3)

= 27

BALL-LOCK PUNCH, PUNCH LARGER THAN SHAFT, SLOT, WITH EJECTOR PIN, LIGHT DUTY

2744.

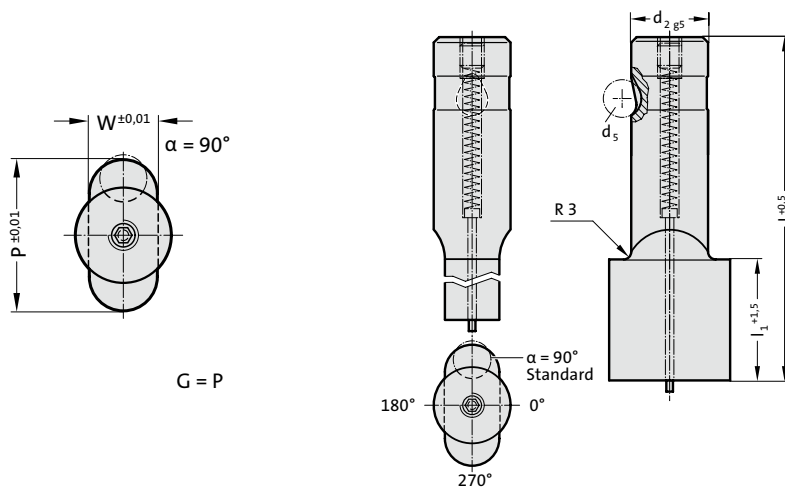

2744. Ball-Lock punch, punch larger than shaft, slot, with ejector pin, light duty

d ₂ / Order No	d ₅	W _{min}	G _{max}	l ₁ / Order No	l (Order Code character)	80 (E)	90 (F)	100 (G)
13 / (3)	8	5	32	19(2) 30(4)		●	●	●
16 / (4)	8	6.5	38	19(2) 30(4)		●	●	●
20 / (5)	8	8	40	19(2) 30(4)		●	●	●
25 / (6)	8	10	44	19(2) 30(4)		●	●	●
32 / (7)	8	11.5	50	19(2) 30(4)		●	●	●

Ordering Code (example):

2744.7F2.3820.1150.B

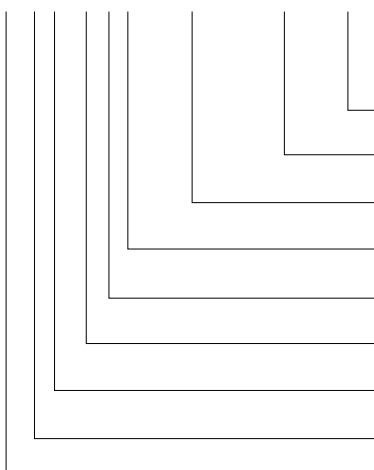

Angle:
90°
Shape: slot, Width W
W = 11,5 mm
Shape: slot, Length P
P = 38,2 mm
Punch cutting length: l₁
19 mm
Length: l
90 mm
Diameter: d₂
32 mm
Type:
punch larger, light
Execution:
slot
Punch:
with ejector pin

Order Code character
= (B)
= 1150
= 3820
Order No
= (2)
Order Code character
= (F)
Order No
= (7)
Order No
= (4)
Order No
= (4)
= 27

Material:

HSS
Hardness 62 ± 2 HRC

Execution:

Shaft and punch shape fine ground.
Special dimensions on request.

BALL-LOCK PUNCH, PUNCH LARGER THAN SHAFT, RECTANGLE WITH RADIUSSED CORNERS, WITH EJECTOR PIN, LIGHT DUTY



2754.

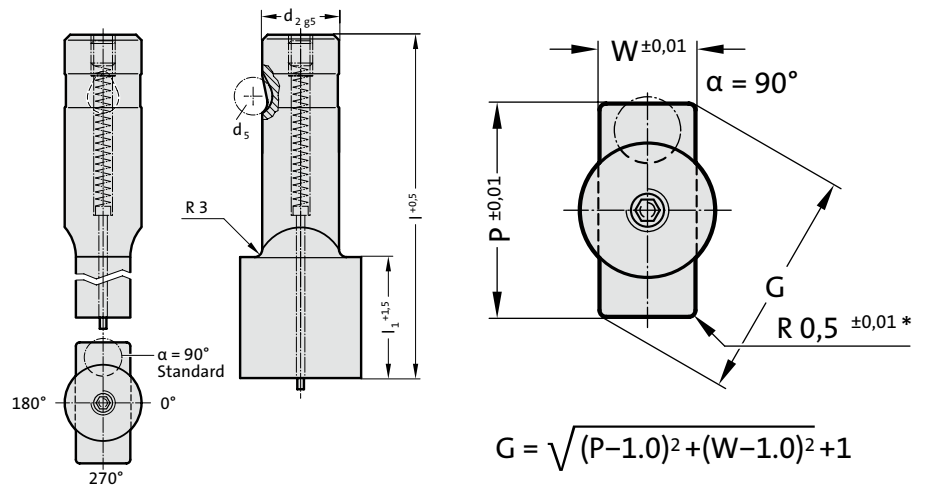

2754. Ball-Lock punch, punch larger than shaft, rectangle with radiused corners, with ejector pin, light duty

d ₂ / Order No	d ₅	W _{min}	G _{max}	l ₁ / Order No	l (Order Code character)	80 (E)	90 (F)	100 (G)
13 / (3)	8	5	32	19(2) 30(4)		●	●	●
16 / (4)	8	6.5	38	19(2) 30(4)		●	●	●
20 / (5)	8	8	40	19(2) 30(4)		●	●	●
25 / (6)	8	10	44	19(2) 30(4)		●	●	●
32 / (7)	8	11.5	50	19(2) 30(4)		●	●	●

Material:

HSS
Hardness 62 ± 2 HRC

Execution:

Shaft and punch shape fine ground.
Special dimensions on request.

* For other radius options, see standardised special shapes.

Ordering Code (example):

2754.7F2.3820.1150.B

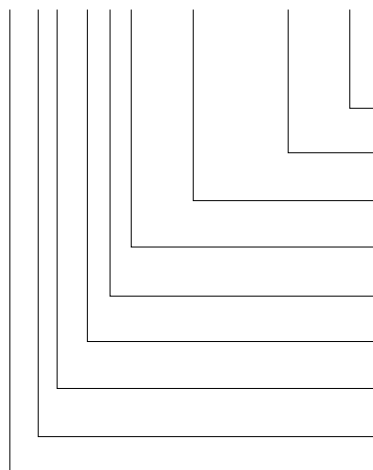

Angle:

90°

Shape: rectangle with radiused corners, Width W
W = 11,5 mm

Shape: rectangle with radiused corners, Length P
P = 38,2 mm

Punch cutting length: l₁
19 mm

Length: l

90 mm

Diameter: d₂

32 mm

Type:

punch larger, light

Execution:
rectangle with radiused corners

Punch:
with ejector pin

Order Code character
= (B)

Order Code character
= 1150

Order Code character
= 3820

Order No
= (2)

Order Code character
= (F)

Order No
= (7)

Order No
= (4)

Order No
= (5)

Order No
= 27

BALL-LOCK PILOT PIN, WITH TAPERED TIP, LIGHT DUTY

2262.

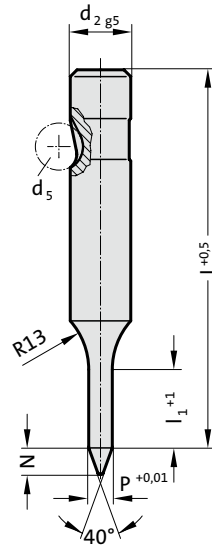

2262. Ball-Lock pilot pin, with tapered tip, light duty

d ₂ / Order No	d ₅	P	I ₁ / Order No	N	I (Order Code character)	71 (D)	80 (E)	90 (F)	100 (G)	110 (H)	125 (J)	140 (K)	150 (L)
10 / (2)	8	5,9 - 9,9	19(2)	8		●	●	●	●	●			
13 / (3)	8	9,9 - 12,9	19(2)	10		●	●	●	●	●	●		
16 / (4)	8	12,9 - 15,9	25(3)	15		●	●	●	●	●	●	●	●
20 / (5)	8	15,9 - 19,9	25(3)	20		●	●	●	●	●	●	●	●
25 / (6)	8	19,9 - 24,9	25(3)	25		●	●	●	●	●	●	●	●
32 / (7)	8	24,9 - 31,9	25(3)	30			●	●	●	●	●	●	●
38 / (8)	8	31,9 - 37,9	30(4)	35			●	●	●	●	●	●	●

Ordering Code (example):

2262.4G3.1410

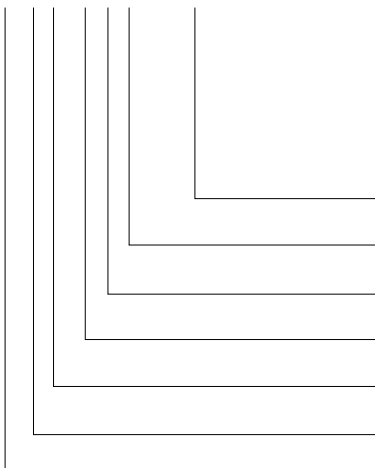

Shape: round

P = ∅ 14,1 mm

Punch cutting length: I₁

25 mm

Length: I

100 mm

Diameter: d₂

16 mm

Type:

light

Execution:

Pilot pin with tapered tip

Punch:

without ejector pin

= 1410

Order No

= (3)

Order Code character

= (G)

Order No

= (4)

Order No

= (2)

Order No

= (6)

= 22

Material:

HSS

Hardness 62 ± 2 HRC

Execution:

Shaft and pilot pin fine ground.

Special dimensions on request.

BALL-LOCK PILOT PIN, WITH PARABOLIC TIP, LIGHT DUTY



2272.

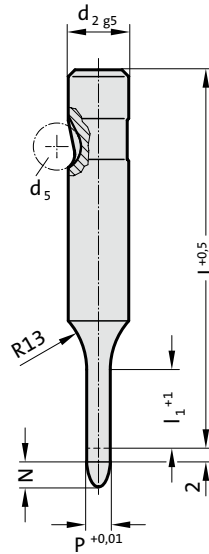

2272. Ball-Lock pilot pin, with parabolic tip, light duty

d ₂ / Order No	d ₅	P	l ₁ / Order No	l (Order Code character)	50 (A)	56 (B)	63 (C)	71 (D)	80 (E)	90 (F)	100 (G)
6 / (1)	6	2,5 - 5,9	13(1)		●	●	●	●	●	●	●
10 / (2)	8	5,9 - 9,9	19(2)		●	●	●	●	●	●	●
13 / (3)	8	9,9 - 12,9	19(2)		●	●	●	●	●	●	●
16 / (4)	8	12,9 - 15,9	25(3)				●	●	●	●	●
20 / (5)	8	15,9 - 19,9	25(3)				●	●	●	●	●
25 / (6)	8	19,9 - 24,9	25(3)				●	●	●	●	●
32 / (7)	8	24,9 - 31,9	25(3)					●	●	●	●
38 / (8)	8	31,9 - 37,9	30(4)						●	●	●

Material:

HSS
Hardness 62 ± 2 HRC

Execution:

Shaft and pilot pin fine ground.
Special dimensions on request.

Note:

The 2 mm length provides full guidance before the blanking punch contacts the sheet metal.

Length of parabolic tip N:

= 8 mm where P ≤ 10 mm
= 12 mm where P 10,1 mm - 15 mm
= 15 mm where P > 15 mm

Ordering Code (example):

2272.4G3.1410

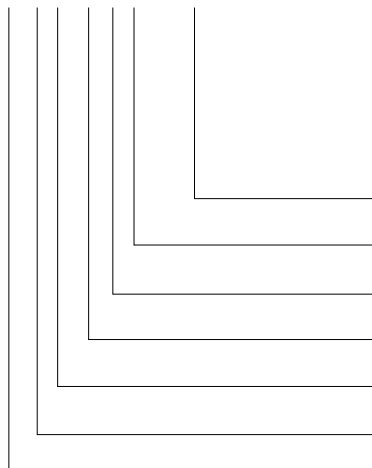

Shape: round

P = ∅ 14,1 mm

Punch cutting length: l₁
25 mm

Length: l

100 mm

Diameter: d₂

16 mm

Type:

light

Execution:

Pilot pin with parabolic tip

Punch:

without ejector pin

= 1410

Order No

= (3)

Order Code character

= (G)

Order No

= (4)

Order No

= (2)

Order No

= (7)

= 22

BALL-LOCK PUNCH, BLANK, HEAVY DUTY

2203.

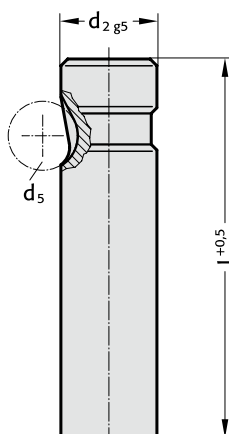

2203. Ball-Lock punch, blank, heavy duty

d ₂ / Order No	d ₅	l / (Order Code character)	63 (C)	71 (D)	80 (E)	90 (F)	100 (G)	110 (H)	125 (J)	140 (K)	150 (L)	175 (M)	200 (N)
10 / (2)	10		●	●	●	●	●	●	●				
13 / (3)	12		●	●	●	●	●	●	●	●	●	●	
16 / (4)	12		●	●	●	●	●	●	●	●	●	●	●
20 / (5)	12		●	●	●	●	●	●	●	●	●	●	●
25 / (6)	12			●	●	●	●	●	●	●	●	●	●
32 / (7)	12			●	●	●	●	●	●	●	●	●	●
40 / (9)	12				●	●	●	●	●	●	●	●	●

Ordering Code (example):

2203.7G

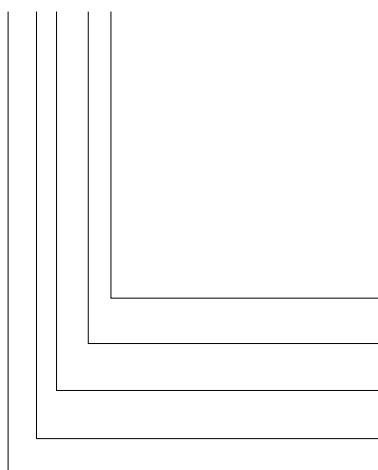

Length: l
100 mm
Diameter: d₂
32 mm
Type:
heavy
Execution:
blank
Punch:
without ejector pin

Order Code character
= (G)
Order No
= (7)
Order No
= (3)
Order No
= (0)
= 22

Material:

HSS
Hardness 62 ± 2 HRC

Execution:

Shaft fine ground.
Special dimensions on request.

BALL-LOCK PUNCH, STEPPED, ROUND, HEAVY DUTY



2213.

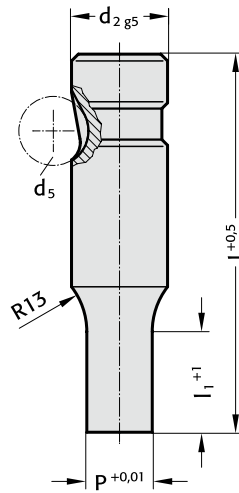

2213. Ball-Lock punch, stepped, round, heavy duty

d ₂ / Order No	d ₅	P	l ₁ / Order No	l (Order Code character)	63 (C)	71 (D)	80 (E)	90 (F)	100 (G)	110 (H)	125 (J)
10 / (2)	10	1,6 - 9,9	13(1) 19(2)		●	●	●	●	●	●	●
13 / (3)	12	5 - 12,9	13(1) 19(2)		●	●	●	●	●	●	●
16 / (4)	12	8 - 15,9	13(1) 19(2) 25(3)		●	●	●	●	●	●	●
20 / (5)	12	12 - 19,9	13(1) 19(2) 25(3)		●	●	●	●	●	●	●
25 / (6)	12	16 - 24,9	13(1) 19(2) 25(3)			●	●	●	●	●	●
32 / (7)	12	24 - 31,9	13(1) 19(2) 25(3)			●	●	●	●	●	●
40 / (9)	12	30 - 39,9	19(2) 25(3) 30(4)				●	●	●	●	●

l₁=10 where P < 2.20

Material:

HSS
Hardness 62 ± 2 HRC

Execution:

Shaft and punch diameter fine ground.
Special dimensions on request.

Ordering Code (example):

2213.7G2.2450

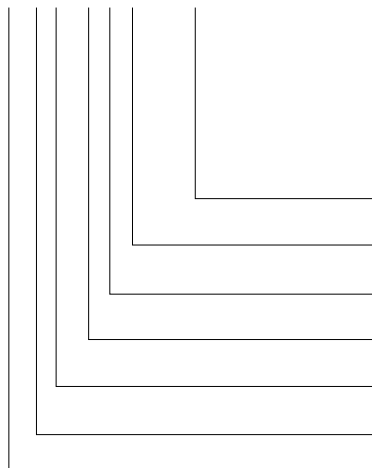

Shape: round

P = Ø 24,5 mm

Punch cutting length: l₁

19 mm

Length: l

100 mm

Diameter: d₂

32 mm

Type:

heavy

Execution:

round

Punch:

without ejector pin

= 2450

Order No

= (2)

Order Code character

= (G)

Order No

= (7)

Order No

= (3)

Order No

= (1)

= 22

BALL-LOCK PUNCH, STEPPED, SQUARE, HEAVY DUTY

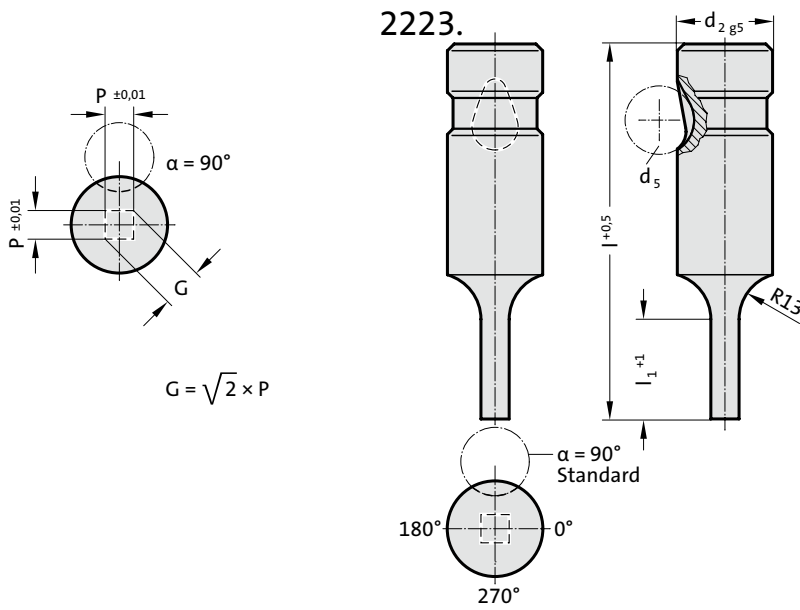

2223. Ball-Lock punch, stepped, square, heavy duty

d ₂ / Order No	d ₅	P _{min}	G _{max}	l ₁ / Order No	l (Order Code character)	63	71	80	90	100	110	125
						(C)	(D)	(E)	(F)	(G)	(H)	(J)
10 / (2)	10	1.6	9.9	13(1) 19(2)		●	●	●	●	●	●	●
13 / (3)	12	4.5	12.9	13(1) 19(2)		●	●	●	●	●	●	●
16 / (4)	12	6	15.9	13(1) 19(2) 25(3)		●	●	●	●	●	●	●
20 / (5)	12	8	19.9	13(1) 19(2) 25(3)		●	●	●	●	●	●	●
25 / (6)	12	10	24.9	13(1) 19(2) 25(3)			●	●	●	●	●	●
32 / (7)	12	12.5	31.9	13(1) 19(2) 25(3)			●	●	●	●	●	●
40 / (9)	12	14	39.9	19(2) 25(3) 30(4)				●	●	●	●	●

l₁=10 where P < 2.20

Ordering Code (example):

2223.3F1.0620.B

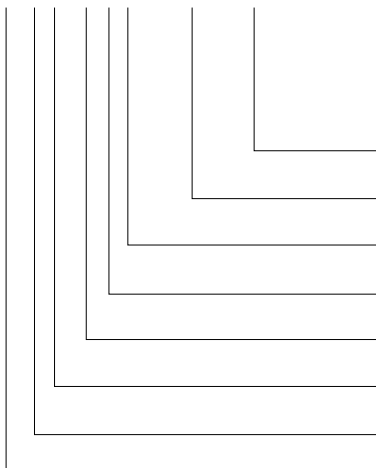

Angle:
90°
Shape: square, Length P
P = 6,2 mm
Punch cutting length: l₁
13 mm
Length: l
90 mm
Diameter: d₂
13 mm
Type:
heavy
Execution:
square
Punch:
without ejector pin

Order Code character
= (B)
Order No
= 0620
Order Code character
= (F)
Order No
= (3)
Order No
= (3)
Order No
= (2)

Material:

HSS
Hardness 62 ± 2 HRC

Execution:

Shaft and punch shape fine ground.
Special dimensions on request.

Note:

With kerf ≤ 0.04 mm, FIBRO rounds off sharp edges if the punch and piercing die bush are ordered together. This reduces the fitting time and the risk of an edge break during operation.

BALL-LOCK PUNCH, STEPPED, RECTANGULAR, HEAVY DUTY



2233.

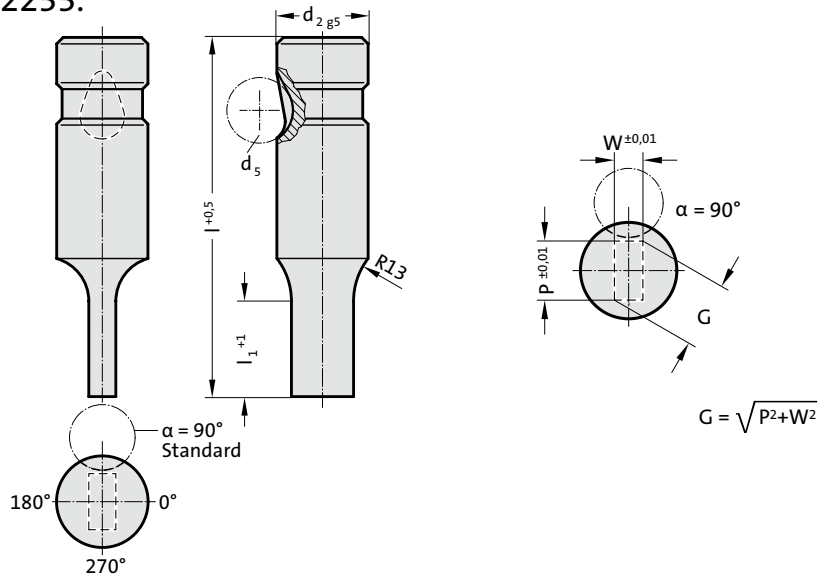

2233. Ball-Lock punch, stepped, rectangular, heavy duty

d ₂ / Order No	d ₅	W _{min}	G _{max}	l ₁ / Order No	l (Order Code character)	63 (C)	71 (D)	80 (E)	90 (F)	100 (G)	110 (H)	125 (J)
10 / (2)	10	1.6	9.9	13(1) 19(2)		●	●	●	●	●	●	●
13 / (3)	12	4.5	12.9	13(1) 19(2)		●	●	●	●	●	●	●
16 / (4)	12	6	15.9	13(1) 19(2) 25(3)		●	●	●	●	●	●	●
20 / (5)	12	8	19.9	13(1) 19(2) 25(3)		●	●	●	●	●	●	●
25 / (6)	12	10	24.9	13(1) 19(2) 25(3)			●	●	●	●	●	●
32 / (7)	12	12.5	31.9	13(1) 19(2) 25(3)			●	●	●	●	●	●
40 / (9)	12	14	39.9	19(2) 25(3) 30(4)				●	●	●	●	●

l₁=10 where W < 2.20

Material:

HSS

Hardness 62 ± 2 HRC

Execution:

Shaft and punch shape fine ground.
Special dimensions on request.

Note:

With kerf ≤ 0.04 mm, FIBRO rounds off sharp edges if the punch and piercing die bush are ordered together. This reduces the fitting time and the risk of an edge break during operation.

Ordering Code (example):

2233.2F1.0650.0450.B

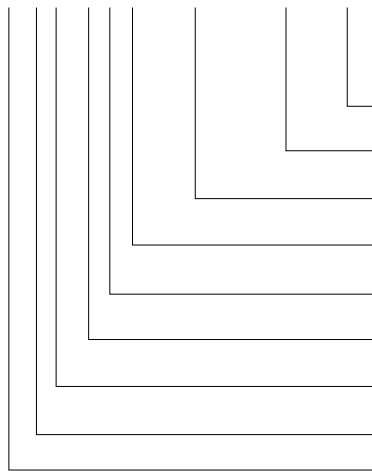

Angle:

90°

Shape: rectangular, Width W

W = 4,5 mm

Shape: rectangular, Length P

P = 6,5 mm

Punch cutting length: l₁

13 mm

Length: l

90 mm

Diameter: d₂

10 mm

Type:

heavy

Execution:

rectangular

Punch:

without ejector pin

Order Code character
= (B)

= 0450

= 0650

Order No

= (1)

Order Code character

= (F)

Order No

= (2)

Order No

= (3)

Order No

= (3)

= 22

BALL-LOCK PUNCH, STEPPED, SLOT, HEAVY DUTY

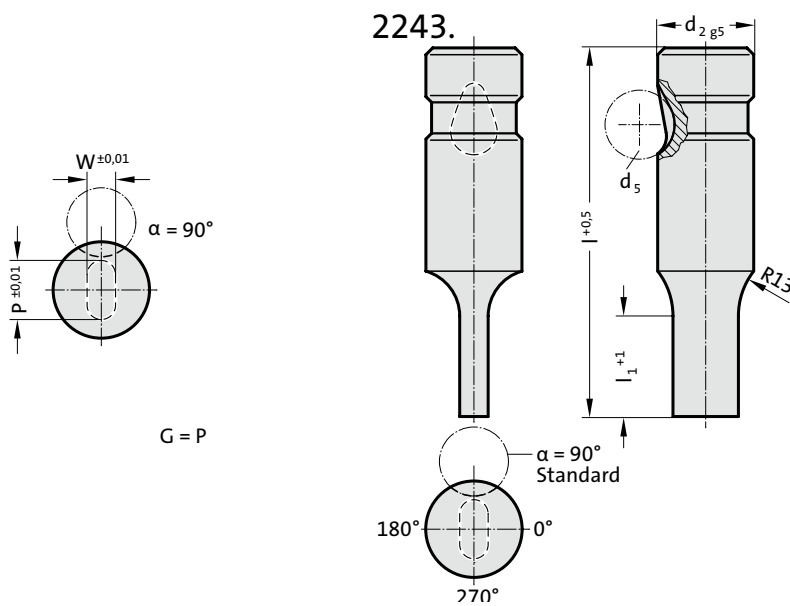

2243. Ball-Lock punch, stepped, slot, heavy duty

d ₂ / Order No	W _{min}	G _{max}	l ₁ / Order No	l (Order Code character)	63 (C)	71 (D)	80 (E)	90 (F)	100 (G)	110 (H)	125 (J)
10 / (2)	1.6	9.9	13(1) 19(2)		●	●	●	●	●	●	●
13 / (3)	4.5	12.9	13(1) 19(2)		●	●	●	●	●	●	●
16 / (4)	6	15.9	13(1) 19(2) 25(3)		●	●	●	●	●	●	●
20 / (5)	8	19.9	13(1) 19(2) 25(3)		●	●	●	●	●	●	●
25 / (6)	10	24.9	13(1) 19(2) 25(3)			●	●	●	●	●	●
32 / (7)	12.5	31.9	13(1) 19(2) 25(3)			●	●	●	●	●	●
40 / (9)	14	39.9	19(2) 25(3) 30(4)				●	●	●	●	●

l₁=10 where W < 2.20

Ordering Code (example):

2243.3E2.1215.0915.B

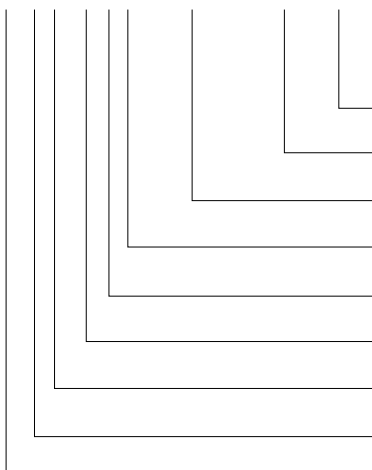

Angle:
90°
Shape: slot, Width W
W = 9,15 mm
Shape: slot, Length P
P = 12,15 mm
Punch cutting length: l₁
19 mm
Length: l
80 mm
Diameter: d₂
13 mm
Type:
heavy
Execution:
slot
Punch:
without ejector pin

Order Code character
= (B)
= 0915
= 1215
Order No
= (2)
Order Code character
= (E)
Order No
= (3)
Order No
= (3)
Order No
= (4)
= 22

Material:

HSS
Hardness 62 ± 2 HRC

Execution:

Shaft and punch shape fine ground.
Special dimensions on request.

BALL-LOCK PUNCH, STEPPED, RECTANGLE WITH RADIUSSED CORNERS, HEAVY DUTY

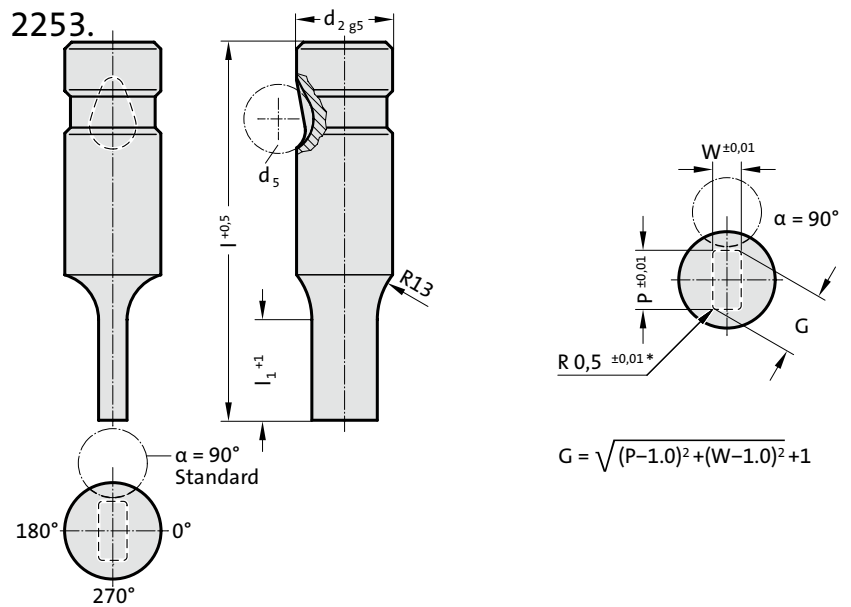

2253. Ball-Lock punch, stepped, rectangle with radiused corners, heavy duty

d ₂ / Order No	W _{min}	G _{max}	l ₁ / Order No	l (Order Code character)	63 (C)	71 (D)	80 (E)	90 (F)	100 (G)	110 (H)	125 (J)
10 / (2)	1.6	9.9	13(1) 19(2)		●	●	●	●	●	●	●
13 / (3)	4.5	12.9	13(1) 19(2)		●	●	●	●	●	●	●
16 / (4)	6	15.9	13(1) 19(2) 25(3)		●	●	●	●	●	●	●
20 / (5)	8	19.9	13(1) 19(2) 25(3)		●	●	●	●	●	●	●
25 / (6)	10	24.9	13(1) 19(2) 25(3)			●	●	●	●	●	●
32 / (7)	12.5	31.9	13(1) 19(2) 25(3)			●	●	●	●	●	●
40 / (9)	14	39.9	19(2) 25(3) 30(4)				●	●	●	●	●

l₁=10 where W < 2.20

Material:

HSS
Hardness 62 ± 2 HRC

Execution:

Shaft and punch shape fine ground.
Special dimensions on request.
* For other radius options, see standardised special shapes.

Ordering Code (example):

2253.2F1.0650.0450.B

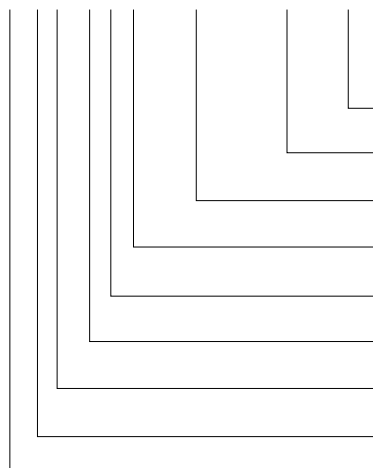

Angle: 90°
Shape: rectangle with radiused corners, Width W
W = 4,5 mm
Shape: rectangle with radiused corners, Length P
P = 6,5 mm
Punch cutting length: l₁
13 mm
Length: l
90 mm
Diameter: d₂
10 mm
Type: heavy
Execution: rectangle with radiused corners
Punch: without ejector pin

Order Code character = (B)
Order No = 0450
Order No = 0650
Order No = (1)
Order Code character = (F)
Order No = (2)
Order No = (3)
Order No = (5)
Order No = 22

BALL-LOCK PUNCH, BLANK, WITH EJECTOR PIN, HEAVY DUTY

2703.

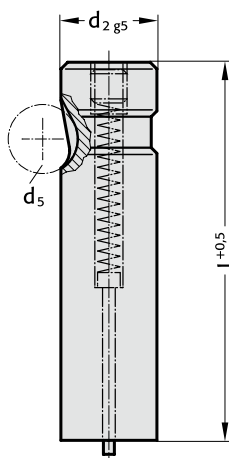

2703. Ball-Lock punch, blank, with ejector pin, heavy duty

d ₂ / Order No	d ₅	l / (Order Code character)	63 (C)	71 (D)	80 (E)	90 (F)	100 (G)	110 (H)	125 (J)
10 / (2)	10		●	●	●	●	●		
13 / (3)	12		●	●	●	●	●	●	●
16 / (4)	12		●	●	●	●	●	●	●
20 / (5)	12		●	●	●	●	●	●	●
25 / (6)	12			●	●	●	●	●	●
32 / (7)	12			●	●	●	●	●	●
40 / (9)	12				●	●	●	●	●

Ordering Code (example):

2703.7G

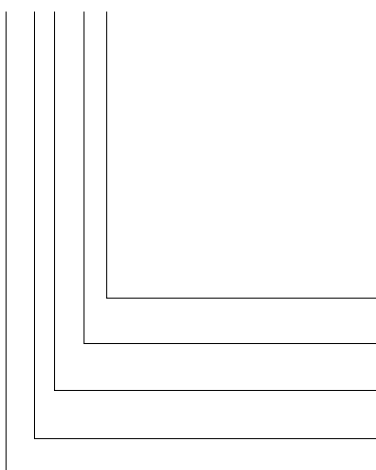

Length: l
100 mm
Diameter: d₂
32 mm
Type:
heavy
Execution:
blank
Punch:
with ejector pin

Order Code character
= (G)
Order No
= (7)
Order No
= (3)
Order No
= (0)
= 27

Material:

HSS
Hardness 62 ± 2 HRC

Execution:

Shaft fine ground.
Special dimensions on request.

POINÇON À BILLE, ÉPAULÉ, ROND, AVEC ÉJECTEUR, FORTE CHARGE



2713.

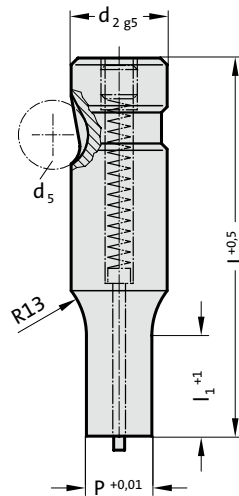

2713. Poinçon à bille, épaulé, rond, avec éjecteur, forte charge

d ₂ / Chiffre de référence	d ₅	P	l ₁ / Chiffre de référence	l (Lettre de référence)	63 (C)	71 (D)	80 (E)	90 (F)	100 (G)	110 (H)	125 (J)
10 / (2)	10	5 - 9,9	13(1) 19(2)		●	●	●	●	●		
13 / (3)	12	6 - 12,9	13(1) 19(2)		●	●	●	●	●	●	●
16 / (4)	12	8 - 15,9	13(1) 19(2) 25(3)		●	●	●	●	●	●	●
20 / (5)	12	10 - 19,9	13(1) 19(2) 25(3)		●	●	●	●	●	●	●
25 / (6)	12	12 - 24,9	13(1) 19(2) 25(3)			●	●	●	●	●	●
32 / (7)	12	16 - 31,9	13(1) 19(2) 25(3)			●	●	●	●	●	●
40 / (9)	12	19 - 39,9	19(2) 25(3) 30(4)				●	●	●	●	●

*à d₂ = 16/ 20 et l = 63; l_{1 max.} = 19

Matière :

HSS

Dureté 62 ± 2 HRC

Exécution :

Corps et diamètre du tranchant superfinis.

Fabrication spéciale sur demande.

Exemple de commande :

2713.3C1.0550

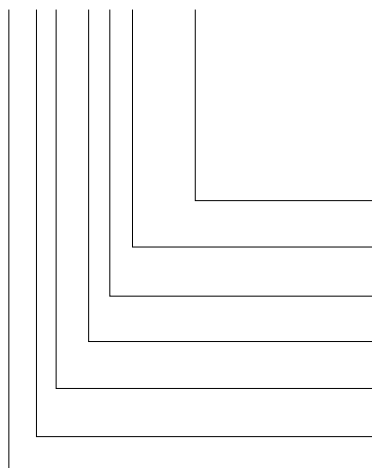

Forme: Rond

P = Ø 5,5 mm

Longueur épaulement: l₁

13 mm

Longueur: l

63 mm

Diamètre: d₂

13 mm

Type:

forte charge

Exécution:

Rond

Poinçon de découpe:

avec éjecteur

= 0550

Chiffre de référence

= (1)

Lettre de référence

= (C)

Chiffre de référence

= (3)

Chiffre de référence

= (3)

Chiffre de référence

= (1)

= 27

POINÇON À BILLE, ÉPAULÉ, CARRÉ, AVEC ÉJECTEUR, FORTE CHARGE

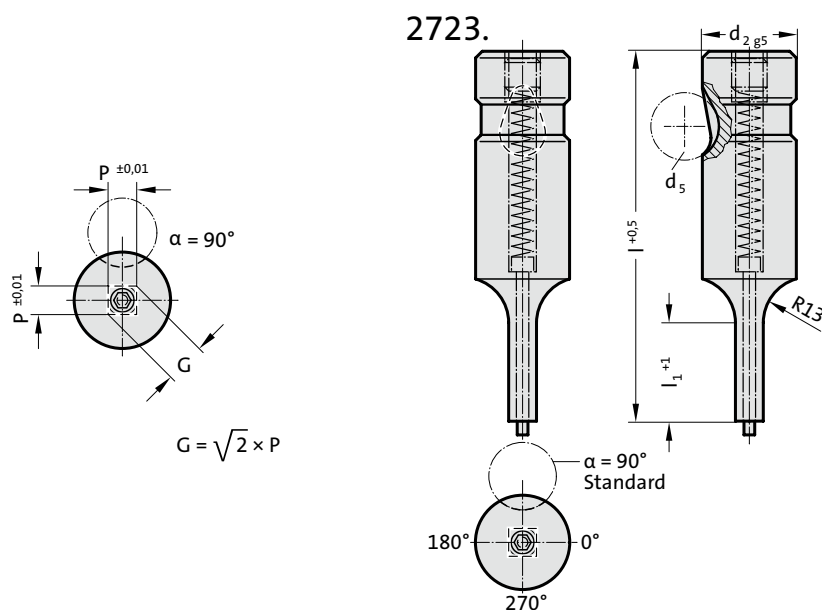

2723. Poinçon à bille, épaulé, carré, avec éjecteur, forte charge

d ₂ / Chiffre de référence	d ₅	P _{min}	G _{max}	l ₁ / Chiffre de référence	l (Lettre de référence)	63 (C)	71 (D)	80 (E)	90 (F)	100 (G)	110 (H)	125 (J)
10 / (2)	10	4	9,9	13(1) 19(2)		●	●	●	●	●		
13 / (3)	12	6	12,9	13(1) 19(2)		●	●	●	●	●	●	●
16 / (4)	12	8	15,9	13(1) 19(2) 25(3)		●	●	●	●	●	●	●
20 / (5)	12	10	19,9	13(1) 19(2) 25(3)		●	●	●	●	●	●	●
25 / (6)	12	12	24,9	13(1) 19(2) 25(3)			●	●	●	●	●	●
32 / (7)	12	16	31,9	13(1) 19(2) 25(3)			●	●	●	●	●	●
40 / (9)	12	19	39,9	19(2) 25(3) 30(4)				●	●	●	●	●

*à d₂ = 16/ 20 et l = 63; l_{1 max.} = 19

Exemple de commande :

2723.2F1.0650.B

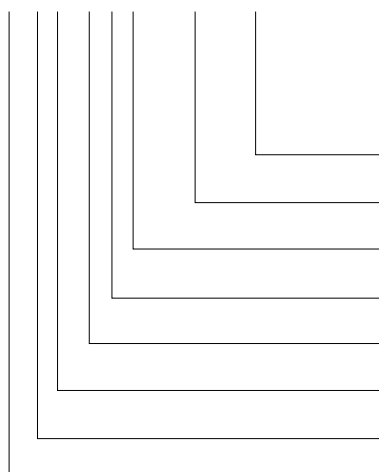

Angle:
90°
Forme: Carré, Longueur P
P = 6,5 mm
Longueur épaulement: l₁
13 mm
Longueur: l
90 mm
Diamètre: d₂
10 mm
Type:
forte charge
Exécution:
Carré
Poinçon de découpe:
avec éjecteur

Lettre de référence
= (B)
Chiffre de référence
= 0650
Lettre de référence
= (F)
Chiffre de référence
= (2)
Chiffre de référence
= (3)
Chiffre de référence
= (2)
Chiffre de référence
= 27

Matière :

HSS
Dureté 62 ± 2 HRC

Exécution :

Corps et embout profilé superfinis.
Fabrication spéciale sur demande.

Remarque :

En cas de fente de coupe ≤ 0,04 mm, FIBRO procède à l'arrondissement des arêtes tranchantes si un poinçon de découpe et une matrice sont commandés ensemble. Cela permet de réduire le temps de montage et les risques de cassure d'arêtes durant le fonctionnement.

POINÇON À BILLE, ÉPAULÉ, RECTANGLE, AVEC ÉJECTEUR, FORTE CHARGE

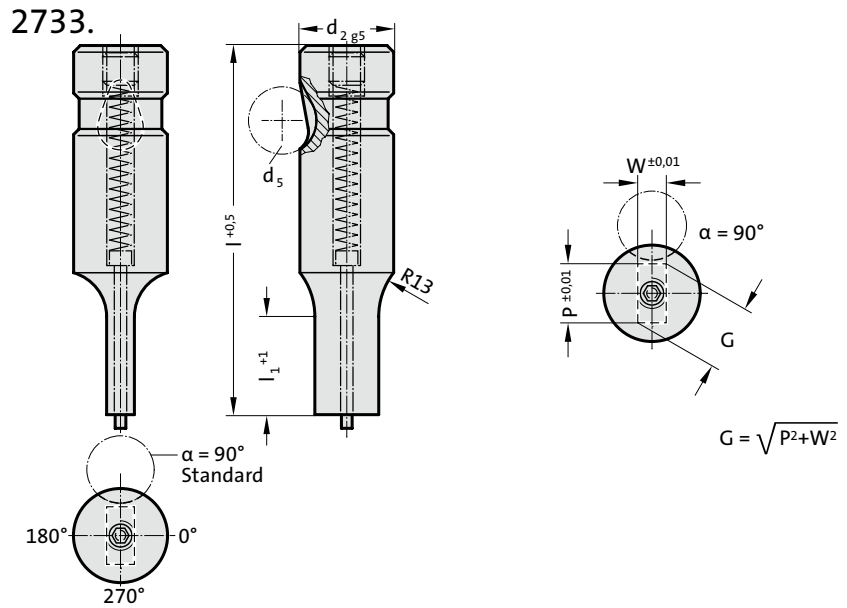

2733. Poinçon à bille, épaulé, rectangle, avec éjecteur, forte charge

d ₂ / Chiffre de référence	d ₅	W _{min}	G _{max}	l ₁ / Chiffre de référence	l (Lettre de référence)	63 (C)	71 (D)	80 (E)	90 (F)	100 (G)	110 (H)	125 (J)
10 / (2)	10	4	9,9	13(1) 19(2)		●	●	●	●	●		
13 / (3)	12	6	12,9	13(1) 19(2)		●	●	●	●	●		
16 / (4)	12	8	15,9	13(1) 19(2) 25(3)		●	●	●	●	●	●	●
20 / (5)	12	10	19,9	13(1) 19(2) 25(3)		●	●	●	●	●	●	●
25 / (6)	12	12	24,9	13(1) 19(2) 25(3)			●	●	●	●	●	●
32 / (7)	12	16	31,9	13(1) 19(2) 25(3)			●	●	●	●	●	●
40 / (9)	12	19	39,9	19(2) 25(3) 30(4)				●	●	●	●	●

*à d₂ = 16/ 20 et l = 63; l_{1 max.} = 19

Matière :

HSS

Dureté 62 ± 2 HRC

Exécution :

Corps et embout profilé superfinis.
Fabrication spéciale sur demande.

Remarque :

En cas de fente de coupe ≤ 0,04 mm, FIBRO procède à l'arrondissement des arêtes tranchantes si un poinçon de découpe et une matrice sont commandés ensemble. Cela permet de réduire le temps de montage et les risques de cassure d'arêtes durant le fonctionnement.

Exemple de commande :

2733.7F2.1420.1250.B

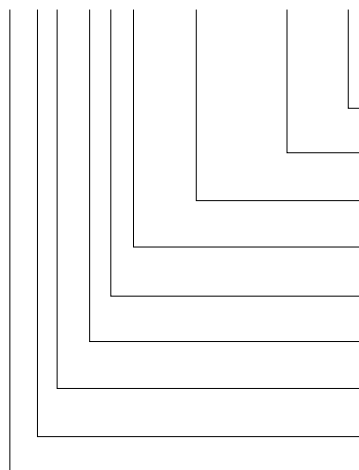

Angle:

90°

Forme: Rectangle, Largeur W

W = 12,50 mm

Forme: Rectangle, Longueur P

P = 14,20 mm

Longueur épaulement: l₁

19 mm

Longueur: l

90 mm

Diamètre: d₂

32 mm

Type:

forte charge

Exécution:

Rectangle

Poinçon de découpe:

avec éjecteur

Lettre de référence

= (B)

= 1250

= 1420

Chiffre de référence

= (2)

Lettre de référence

= (F)

Chiffre de référence

= (7)

Chiffre de référence

= (3)

Chiffre de référence

= (3)

= 27

POINÇON À BILLE, ÉPAULÉ, TROU OBLONG, AVEC ÉJECTEUR, FORTE CHARGE

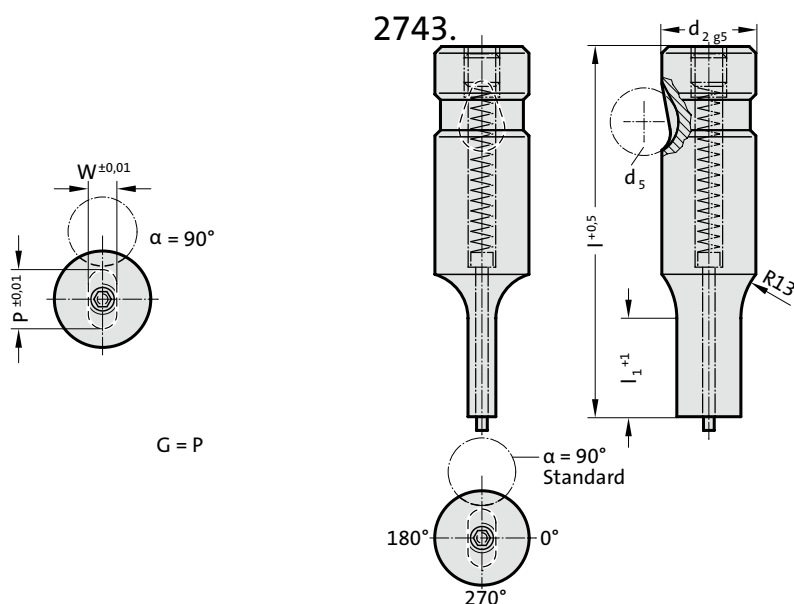

2743. Poinçon à bille, épaulé, trou oblong, avec éjecteur, forte charge

d ₂ / Chiffre de référence	d ₅	W _{min}	G _{max}	l ₁ / Chiffre de référence	l (Lettre de référence)	63 (C)	71 (D)	80 (E)	90 (F)	100 (G)	110 (H)	125 (J)
10 / (2)	10	4	9,9	13(1) 19(2)		●	●	●	●	●		
13 / (3)	12	6	12,9	13(1) 19(2)		●	●	●	●	●	●	●
16 / (4)	12	8	15,9	13(1) 19(2) 25(3)		●	●	●	●	●	●	●
20 / (5)	12	10	19,9	13(1) 19(2) 25(3)		●	●	●	●	●	●	●
25 / (6)	12	12	24,9	13(1) 19(2) 25(3)			●	●	●	●	●	●
32 / (7)	12	16	31,9	13(1) 19(2) 25(3)			●	●	●	●	●	●
40 / (9)	12	19	39,9	19(2) 25(3) 30(4)				●	●	●	●	●

*à d₂ = 16/ 20 et l = 63; l_{1 max.} = 19

Exemple de commande :

2743.2F1.0650.0450.B

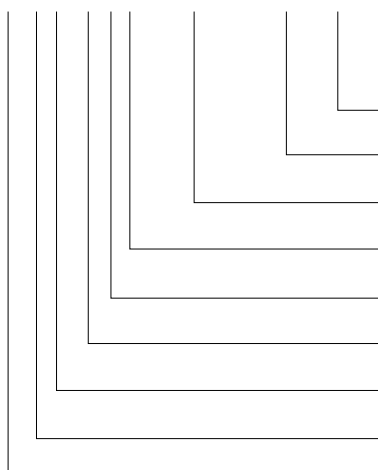

Angle:

90°

Forme: Trou oblong, Largeur W

W = 4,50 mm

Forme: Trou oblong, Longueur P

P = 6,50 mm

Longueur épaulement: l₁

13 mm

Longueur: l

90 mm

Diamètre: d₂

10 mm

Type:

forte charge

Exécution:

Trou oblong

Poinçon de découpe:

avec éjecteur

Lettre de référence

= (B)

= 0450

= 0650

Chiffre de référence

= (1)

Lettre de référence

= (F)

Chiffre de référence

= (2)

Chiffre de référence

= (3)

Chiffre de référence

= (4)

= 27

Matière :

HSS

Dureté 62 ± 2 HRC

Exécution :

Corps et embout profilé superfinis.

Fabrication spéciale sur demande.

POINÇON À BILLE, ÉPAULÉ, RECTANGLE AVEC RAYON, AVEC ÉJECTEUR, FORTE CHARGE

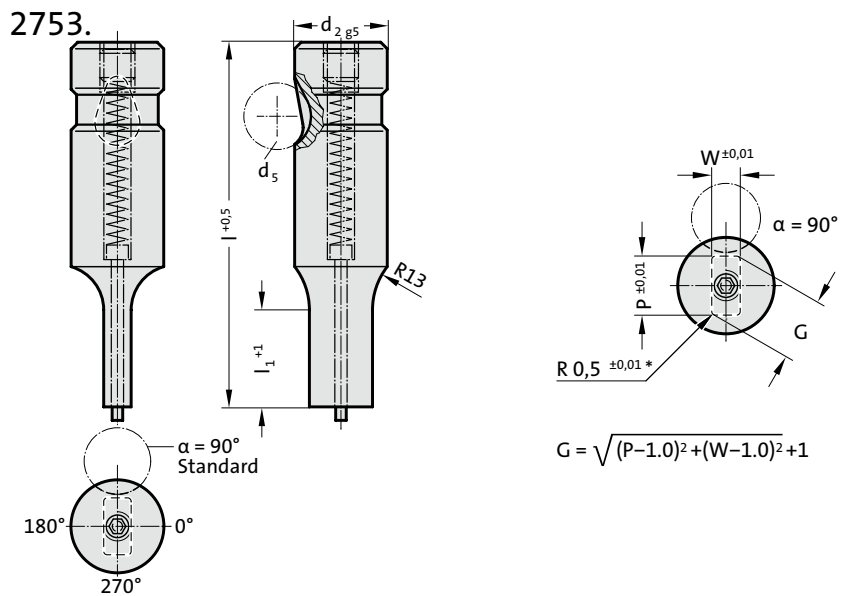

2753. Poinçon à bille, épaulé, rectangle avec rayon, avec éjecteur, forte charge

d ₂ / Chiffre de référence	d ₅	W _{min}	G _{max}	l ₁ / Chiffre de référence	l (Lettre de référence)	63 (C)	71 (D)	80 (E)	90 (F)	100 (G)	110 (H)	125 (J)
10 / (2)	10	4	9,9	13(1) 19(2)		●	●	●	●	●		
13 / (3)	12	6	12,9	13(1) 19(2)		●	●	●	●	●	●	●
16 / (4)	12	8	15,9	13(1) 19(2) 25(3)		●	●	●	●	●	●	●
20 / (5)	12	10	19,9	13(1) 19(2) 25(3)		●	●	●	●	●	●	●
25 / (6)	12	12	24,9	13(1) 19(2) 25(3)			●	●	●	●	●	●
32 / (7)	12	16	31,9	13(1) 19(2) 25(3)			●	●	●	●	●	●
40 / (9)	12	19	39,9	19(2) 25(3) 30(4)				●	●	●	●	●

*à d₂ = 16/ 20 et l = 63; l_{1 max.} = 19

Matière :

HSS
Dureté 62 ± 2 HRC

Exécution :

Corps et embout profilé superfinis.
Fabrication spéciale sur demande.
* Pour un autre rayon, voire Formées spéciales normalisées.

Exemple de commande :

2753.3F1.1215.0915.B

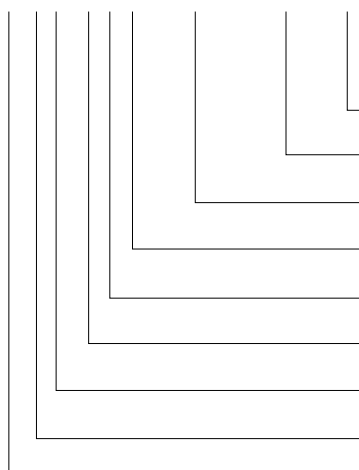

Angle: 90°
Forme: Rectangle avec rayon, Largeur W W = 9,15 mm
Forme: Rectangle avec rayon, Longueur P P = 12,15 mm
Longueur épaulement: l₁ 13 mm
Longueur: l 90 mm
Diamètre: d₂ 13 mm
Type: forte charge
Exécution: Rectangle avec rayon
Poinçon de découpe: avec éjecteur

Lettre de référence = (B)
Chiffre de référence = 0915
Chiffre de référence = 1215
Chiffre de référence = (1)
Lettre de référence = (F)
Chiffre de référence = (3)
Chiffre de référence = (3)
Chiffre de référence = (5)
Chiffre de référence = 27

BALL-LOCK PUNCH, PUNCH LARGER THAN SHAFT, BLANK, HEAVY DUTY

2205.

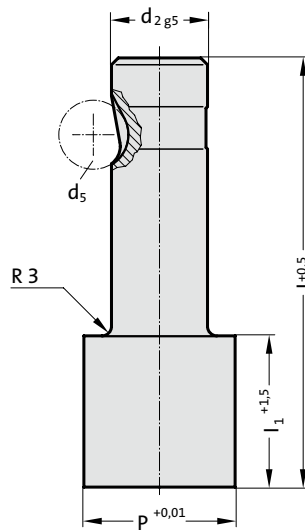
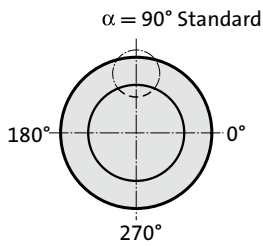

2205. Ball-Lock punch, punch larger than shaft, blank, heavy duty

d ₂ / Order No	d ₅	P	l ₁ / Order No	l (Order Code character)	80	90	100
					(E)	(F)	(G)
13 / (3)	12	32	19(2) 30(4)		●	●	●
16 / (4)	12	38	19(2) 30(4)		●	●	●
20 / (5)	12	40	19(2) 30(4)		●	●	●
25 / (6)	12	44	19(2) 30(4)		●	●	●
32 / (7)	12	50	19(2) 30(4)		●	●	●
40 / (9)	12	56	19(2) 30(4)		●	●	●

Ordering Code (example):

2205.7G4.5000

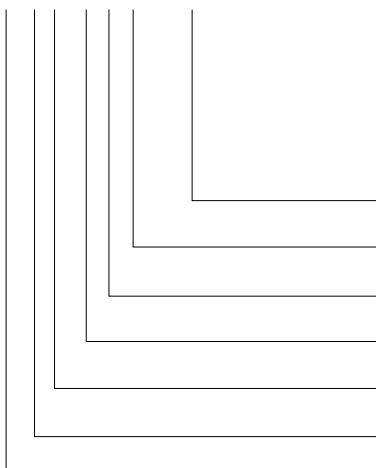

Shape: round

P = Ø 50 mm

Punch cutting length: l₁

30 mm

Length: l

100 mm

Diameter: d₂

32 mm

Type:

punch larger, heavy

Execution:

blank

Punch:

without ejector pin

= 5000

Order No

= (4)

Order Code character

= (G)

Order No

= (7)

Order No

= (5)

Order No

= (0)

= 22

Material:

HSS

Hardness 62 ± 2 HRC

Execution:

Shaft and punch diameter fine ground.

Special dimensions on request.

BALL-LOCK PUNCH, PUNCH LARGER THAN SHAFT, ROUND, HEAVY DUTY



2215.

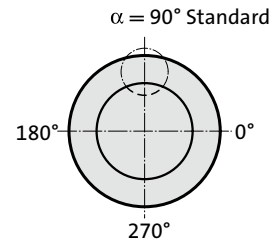
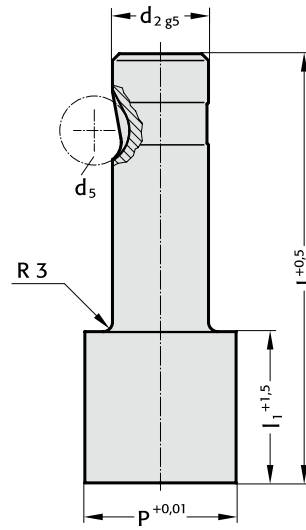

2215. Ball-Lock punch, punch larger than shaft, round, heavy duty

d ₂ / Order No	d ₅	P	l ₁ / Order No	l (Order Code character)	80 (E)	90 (F)	100 (G)
13 / (3)	12	13,1 - 32	19(2) 30(4)		●	●	●
16 / (4)	12	16,1 - 38	19(2) 30(4)		●	●	●
20 / (5)	12	20,1 - 40	19(2) 30(4)		●	●	●
25 / (6)	12	25,1 - 44	19(2) 30(4)		●	●	●
32 / (7)	12	32,1 - 50	19(2) 30(4)		●	●	●
40 / (9)	12	40,1 - 56	19(2) 30(4)		●	●	●

Material:

HSS
Hardness 62 ± 2 HRC

Execution:

Shaft and punch diameter fine ground.
Special dimensions on request.

Ordering Code (example):

2215.7G2.3210

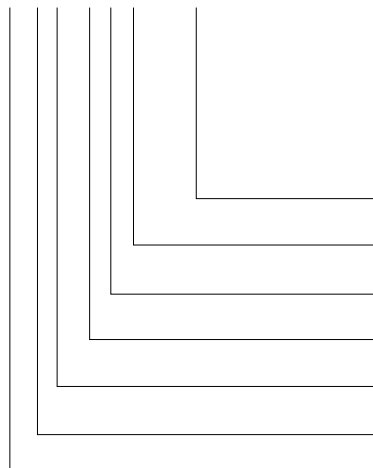

Shape: round

P = ∅ 32,1 mm

Punch cutting length: l₁

19 mm

Length: l

100 mm

Diameter: d₂

32 mm

Type:

punch larger, heavy

Execution:

round

Punch:

without ejector pin

= 3210

Order No

= (2)

Order Code character

= (G)

Order No

= (7)

Order No

= (5)

Order No

= (1)

= 22

BALL-LOCK PUNCH, PUNCH LARGER THAN SHAFT, SQUARE, HEAVY DUTY

2225.

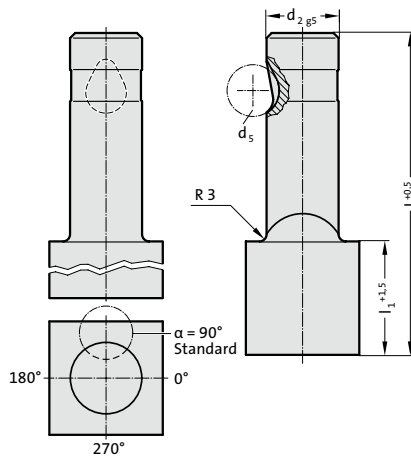
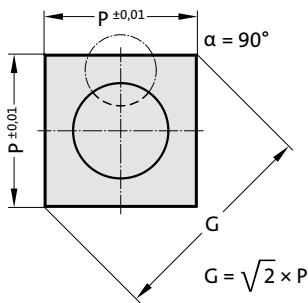

2225. Ball-Lock punch, punch larger than shaft, square, heavy duty

d ₂ / Order No	d ₅	P _{min}	G _{max}	l ₁ / Order No	l (Order Code character)	80 (E)	90 (F)	100 (G)
13 / (3)	12	9.19	32	19(2) 30(4)		●	●	●
16 / (4)	12	11.31	38	19(2) 30(4)		●	●	●
20 / (5)	12	14.14	40	19(2) 30(4)		●	●	●
25 / (6)	12	17.68	44	19(2) 30(4)		●	●	●
32 / (7)	12	22.63	50	19(2) 30(4)		●	●	●
40 / (9)	12	28.28	56	19(2) 30(4)		●	●	●

Ordering Code (example):

2225.4F4.1150.B

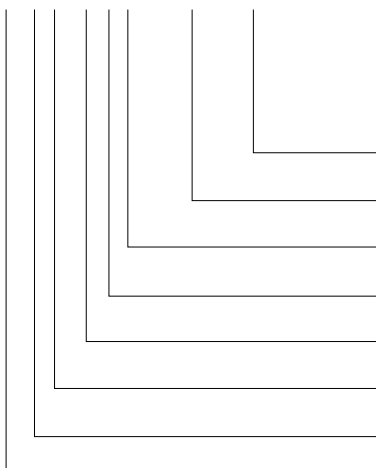

Angle:
90°
Shape: square, Length P
P = 11,5 mm
Punch cutting length: l₁
30 mm
Length: l
90 mm
Diameter: d₂
16 mm
Type:
punch larger, heavy
Execution:
square
Punch:
without ejector pin

Order Code character
= (B)
Order No
= 1150
Order Code character
= (F)
Order No
= (4)
Order Code character
= (4)
Order No
= (5)
Order Code character
= (2)

Material:

HSS
Hardness 62 ± 2 HRC

Execution:

Shaft and punch shape fine ground.
Special dimensions on request.

Note:

With kerf ≤ 0.04 mm, FIBRO rounds off sharp edges if the punch and piercing die bush are ordered together. This reduces the fitting time and the risk of an edge break during operation.

BALL-LOCK PUNCH, PUNCH LARGER THAN SHAFT, RECTANGULAR, HEAVY DUTY



2235.

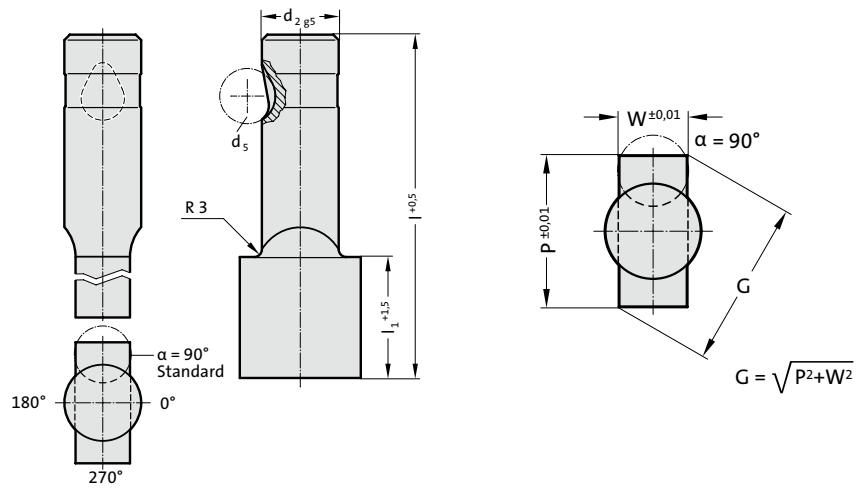

2235. Ball-Lock punch, punch larger than shaft, rectangular, heavy duty

d ₂ / Order No	d ₅	W _{min}	G _{max}	l ₁ / Order No	l (Order Code character)	80 (E)	90 (F)	100 (G)
13 / (3)	12	5	32	19(2) 30(4)		●	●	●
16 / (4)	12	6.5	38	19(2) 30(4)		●	●	●
20 / (5)	12	8	40	19(2) 30(4)		●	●	●
25 / (6)	12	10	44	19(2) 30(4)		●	●	●
32 / (7)	12	11.5	50	19(2) 30(4)		●	●	●
40 / (9)	12	14	56	19(2) 30(4)		●	●	●

Material:

HSS
Hardness 62 ± 2 HRC

Execution:

Shaft and punch shape fine ground.
Special dimensions on request.

Note:

With kerf ≤ 0.04 mm, FIBRO rounds off sharp edges if the punch and piercing die bush are ordered together. This reduces the fitting time and the risk of an edge break during operation.

Ordering Code (example):

2235.4F4.1420.1150.B

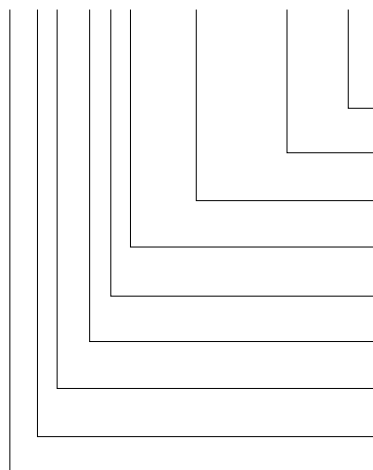

Angle:

90°

Shape: rectangular, Width W

W = 11,5 mm

Shape: rectangular, Length P

P = 14,2 mm

Punch cutting length: l₁

30 mm

Length: l

90 mm

Diameter: d₂

16 mm

Type:

punch larger, heavy

Execution:

rectangular

Punch:

without ejector pin

Order Code character

= (B)

= 1150

= 1420

Order No

= (4)

Order Code character

= (F)

Order No

= (4)

Order No

= (5)

Order No

= (3)

= 22

BALL-LOCK PUNCH, PUNCH LARGER THAN SHAFT, SLOT, HEAVY DUTY

2245.

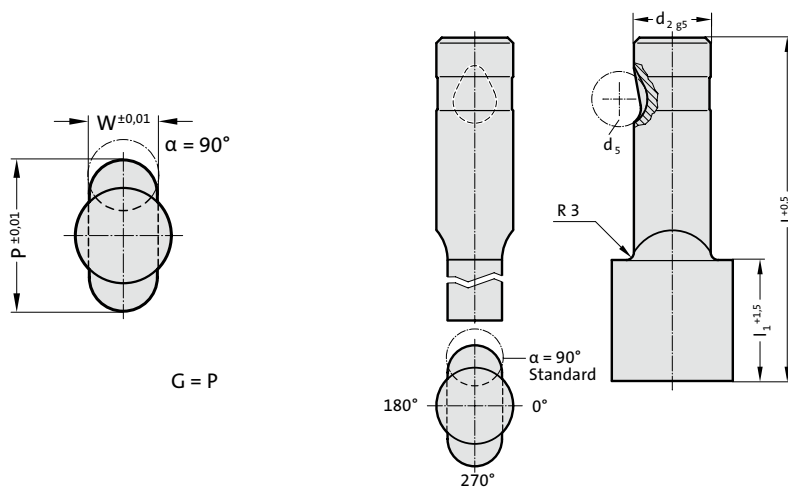

2245. Ball-Lock punch, punch larger than shaft, slot, heavy duty

d ₂ / Order No	d ₅	W _{min}	G _{max}	l ₁ / Order No	l (Order Code character)	80	90	100
						(E)	(F)	(G)
13 / (3)	12	5	32	19(2) 30(4)		●	●	●
16 / (4)	12	6.5	38	19(2) 30(4)		●	●	●
20 / (5)	12	8	40	19(2) 30(4)		●	●	●
25 / (6)	12	10	44	19(2) 30(4)		●	●	●
32 / (7)	12	11.5	50	19(2) 30(4)		●	●	●
40 / (9)	12	14	56	19(2) 30(4)		●	●	●

Ordering Code (example):

2245.7F2.3720.1150.B

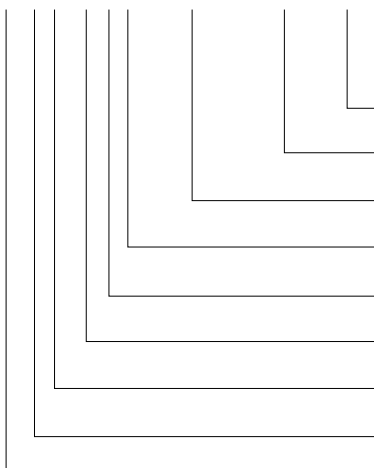

Angle:
90°
Shape: slot, Width W
W = 11,5 mm
Shape: slot, Length P
P = 37,2 mm
Punch cutting length: l₁
19 mm
Length: l
90 mm
Diameter: d₂
32 mm
Type:
punch larger, heavy
Execution:
slot
Punch:
without ejector pin

Order Code character
= (B)
= 1150
= 3720
Order No
= (2)
Order Code character
= (F)
Order No
= (7)
Order No
= (5)
Order No
= (4)
= 22

Material:

HSS
Hardness 62 ± 2 HRC

Execution:

Shaft and punch shape fine ground.
Special dimensions on request.

BALL-LOCK PUNCH, PUNCH LARGER THAN SHAFT, RECTANGLE WITH RADIUSSED CORNERS, HEAVY DUTY



2255.

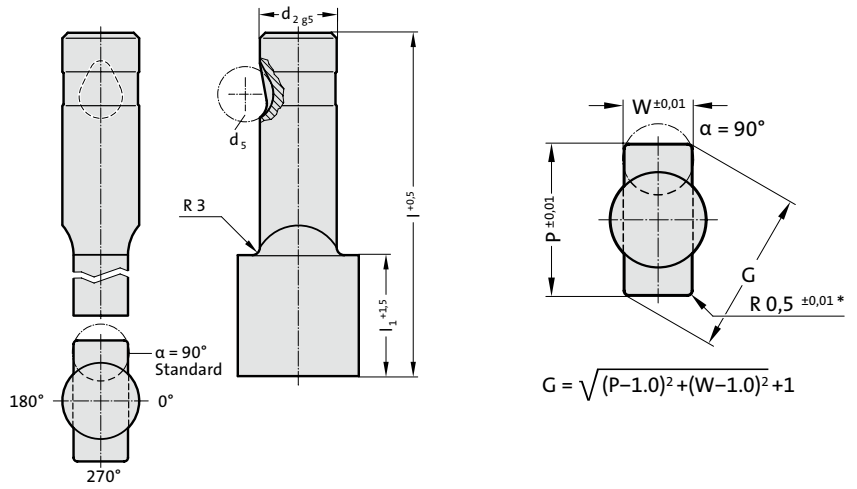

2255. Ball-Lock punch, punch larger than shaft, rectangle with radiussed corners, heavy duty

d ₂ / Order No	d ₅	W _{min}	G _{max}	l ₁ / Order No	l (Order Code character)	80 (E)	90 (F)	100 (G)
13 / (3)	12	5	32	19(2) 30(4)		●	●	●
16 / (4)	12	6.5	38	19(2) 30(4)		●	●	●
20 / (5)	12	8	40	19(2) 30(4)		●	●	●
25 / (6)	12	10	44	19(2) 30(4)		●	●	●
32 / (7)	12	11.5	50	19(2) 30(4)		●	●	●
40 / (9)	12	14	56	19(2) 30(4)		●	●	●

Material:

HSS
Hardness 62 ± 2 HRC

Execution:

Shaft and punch shape fine ground.
Special dimensions on request.

* For other radius options, see standardised special shapes.

Ordering Code (example):

2255.4F2.1420.1150.B

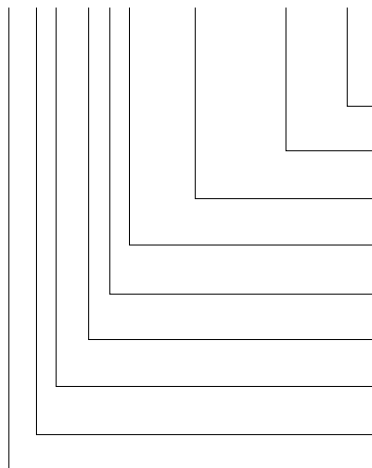

Angle:

90°

Shape: rectangle with radiused corners, Width W

W = 11,5 mm

Shape: rectangle with radiused corners, Length P

P = 14,2 mm

Punch cutting length: l₁

19 mm

Length: l

90 mm

Diameter: d₂

16 mm

Type:

punch larger, heavy

Execution:

rectangle with radiused corners

Punch:

without ejector pin

Order Code character
= (B)

Order Code character
= (F)

Order Code character
= (2)

Order Code character
= (F)

Order Code character
= (4)

Order Code character
= (5)

Order Code character
= (5)

Order Code character
= (5)

Order Code character
= 22

BALL-LOCK PUNCH, PUNCH LARGER THAN SHAFT, BLANK, WITH EJECTOR PIN, HEAVY DUTY

2705.

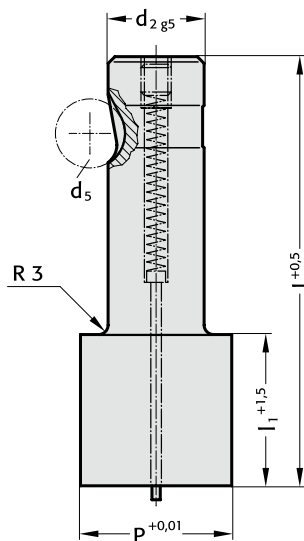
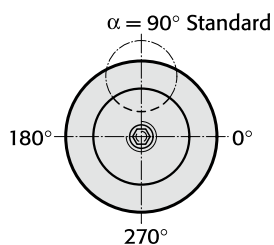

2705. Ball-Lock punch, punch larger than shaft, blank, with ejector pin, heavy duty

d ₂ / Order No	P	l ₁ / Order No	I (Order Code character)	80 (E)	90 (F)	100 (G)
13 / (3)	32	19 (2) 30 (4)		●	●	●
16 / (4)	38	19 (2) 30 (4)		●	●	●
20 / (5)	40	19 (2) 30 (4)		●	●	●
25 / (6)	44	19 (2) 30 (4)		●	●	●
32 / (7)	50	19 (2) 30 (4)		●	●	●
40 / (9)	56	19 (2) 30 (4)		●	●	●

Ordering Code (example):

2705.7G4.5000

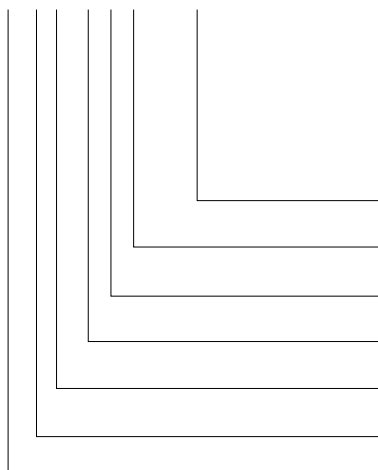

Shape: round
 P = Ø 50 mm
Punch cutting length: l₁
 30 mm
Length: l
 100 mm
Diameter: d₂
 32 mm
Type:
 punch larger, heavy
Execution:
 blank
Punch:
 with ejector pin

= 5000
Order No
 = (4)
Order Code character
 = (G)
Order No
 = (7)
Order No
 = (5)
Order No
 = (0)

= 27

Material:

HSS
 Hardness 62 ± 2 HRC

Execution:

Shaft and punch diameter fine ground.
 Special dimensions on request.

BALL-LOCK PUNCH, PUNCH LARGER THAN SHAFT, ROUND, WITH EJECTOR PIN, HEAVY DUTY



2715.

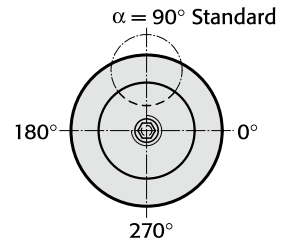
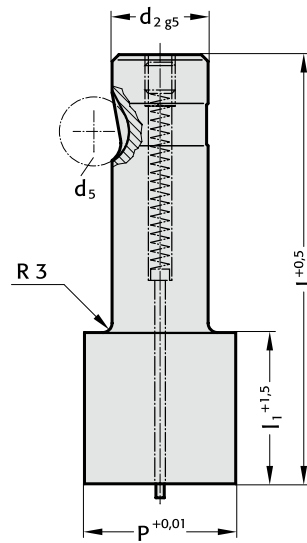

2715. Ball-Lock punch, punch larger than shaft, round, with ejector pin, heavy duty

d ₂ / Order No	d ₅	P	l ₁ / Order No	l (Order Code character)	80 (E)	90 (F)	100 (G)
13 / (3)	12	13,1 - 32	19 (2) 30 (4)		●	●	●
16 / (4)	12	16,1 - 38	19 (2) 30 (4)		●	●	●
20 / (5)	12	20,1 - 40	19 (2) 30 (4)		●	●	●
25 / (6)	12	25,1 - 44	19 (2) 30 (4)		●	●	●
32 / (7)	12	32,1 - 50	19 (2) 30 (4)		●	●	●
40 / (9)	12	40,1 - 56	19 (2) 30 (4)		●	●	●

Material:

HSS
Hardness 62 ± 2 HRC

Execution:

Shaft and punch diameter fine ground.
Special dimensions on request.

Ordering Code (example):

2715.7G2.3210

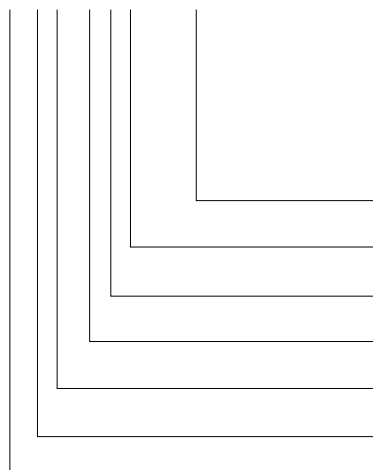

Shape: round

P = Ø 32,1 mm

Punch cutting length: l₁
19 mm

Length: l

100 mm

Diameter: d₂

32 mm

Type:

punch larger, heavy

Execution:

round

Punch:

with ejector pin

= 3210

Order No

= (2)

Order Code character

= (G)

Order No

= (7)

Order No

= (5)

Order No

= (1)

= 27

BALL-LOCK PUNCH, PUNCH LARGER THAN SHAFT, SQUARE, WITH EJECTOR PIN, HEAVY DUTY

2725.

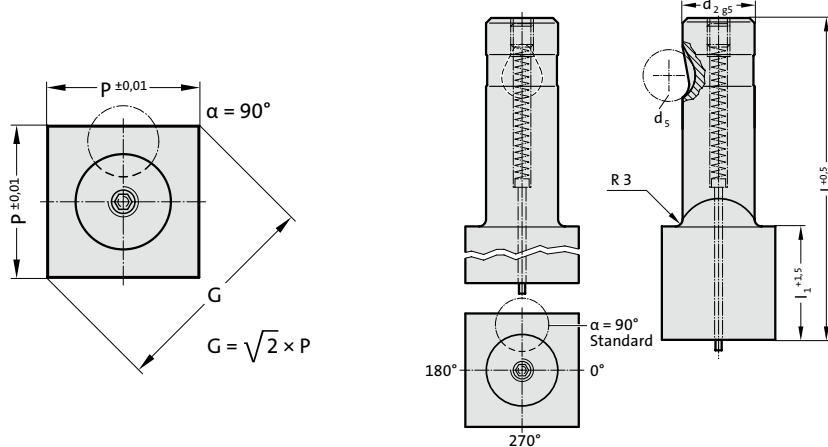

2725. Ball-Lock punch, punch larger than shaft, square, with ejector pin, heavy duty

d ₂ / Order No	d ₅	P _{min}	G _{max}	l ₁ / Order No	l (Order Code character)	80 (E)	90 (F)	100 (G)
13 / (3)	12	9.19	32	19 (2) 30 (4)		●	●	●
16 / (4)	12	11.31	38	19 (2) 30 (4)		●	●	●
20 / (5)	12	14.14	40	19 (2) 30 (4)		●	●	●
25 / (6)	12	17.68	44	19 (2) 30 (4)		●	●	●
32 / (7)	12	22.63	50	19 (2) 30 (4)		●	●	●
40 / (9)	12	28.28	56	19 (2) 30 (4)		●	●	●

Ordering Code (example):

2725.4F4.2450.B

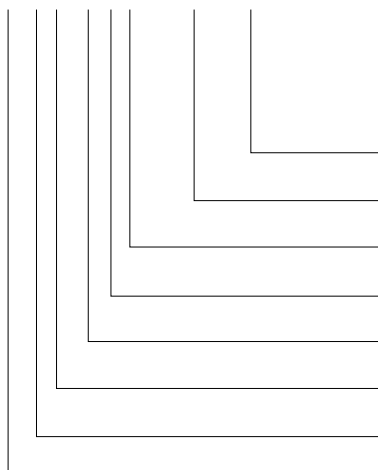

Angle:
90°
Shape: square, Length P
P = 24,5 mm
Punch cutting length: l₁
30 mm
Length: l
90 mm
Diameter: d₂
16 mm
Type:
punch larger, heavy
Execution:
square
Punch:
with ejector pin

Order Code character
= (B)
Order No
= 2450
Order Code character
= (F)
Order No
= (4)
Order No
= (5)
Order No
= (2)

Material:

HSS
Hardness 62 ± 2 HRC

Execution:

Shaft and punch shape fine ground.
Special dimensions on request.

Note:

With kerf ≤ 0.04 mm, FIBRO rounds off sharp edges if the punch and piercing die bush are ordered together. This reduces the fitting time and the risk of an edge break during operation.

BALL-LOCK PUNCH, PUNCH LARGER THAN SHAFT, RECTANGULAR, WITH EJECTOR PIN, HEAVY DUTY



2735.

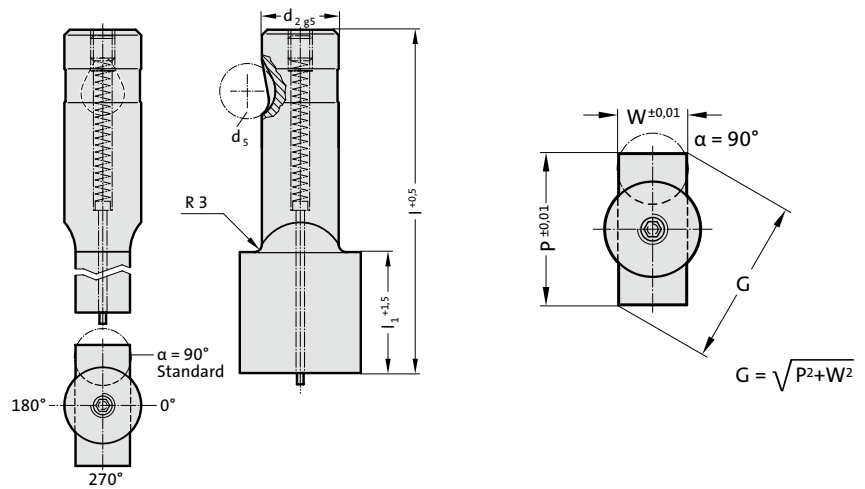

2735. Ball-Lock punch, punch larger than shaft, rectangular, with ejector pin, heavy duty

d ₂ / Order No	d ₅	W _{min}	G _{max}	l ₁ / Order No	l (Order Code character)	80	90	100
						(E)	(F)	(G)
13 / (3)	12	5	32	19 (2) 30 (4)		●	●	●
16 / (4)	12	6.5	38	19 (2) 30 (4)		●	●	●
20 / (5)	12	8	40	19 (2) 30 (4)		●	●	●
25 / (6)	12	10	44	19 (2) 30 (4)		●	●	●
32 / (7)	12	11.5	50	19 (2) 30 (4)		●	●	●
40 / (9)	12	14	56	19 (2) 30 (4)		●	●	●

Material:

HSS
Hardness 62 ± 2 HRC

Execution:

Shaft and punch shape fine ground.
Special dimensions on request.

Note:

With kerf ≤ 0.04 mm, FIBRO rounds off sharp edges if the punch and piercing die bush are ordered together. This reduces the fitting time and the risk of an edge break during operation.

Ordering Code (example):

2735.4F4.1420.1150.B

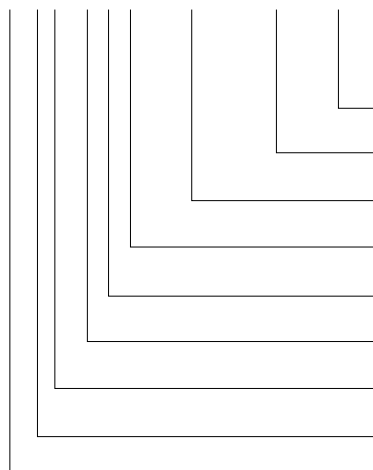

Angle:

90°

Shape: rectangular, Width W

W = 11,5 mm

Shape: rectangular, Length P

P = 14,2 mm

Punch cutting length: l₁

30 mm

Length: l

90 mm

Diameter: d₂

16 mm

Type:

punch larger, heavy

Execution:

rectangular

Punch:

with ejector pin

Order Code character

= (B)

= 1150

= 1420

Order No

= (4)

Order Code character

= (F)

Order No

= (4)

Order No

= (5)

Order No

= (3)

= 27

BALL-LOCK PUNCH, PUNCH LARGER THAN SHAFT, SLOT, WITH EJECTOR PIN, HEAVY DUTY

2745.

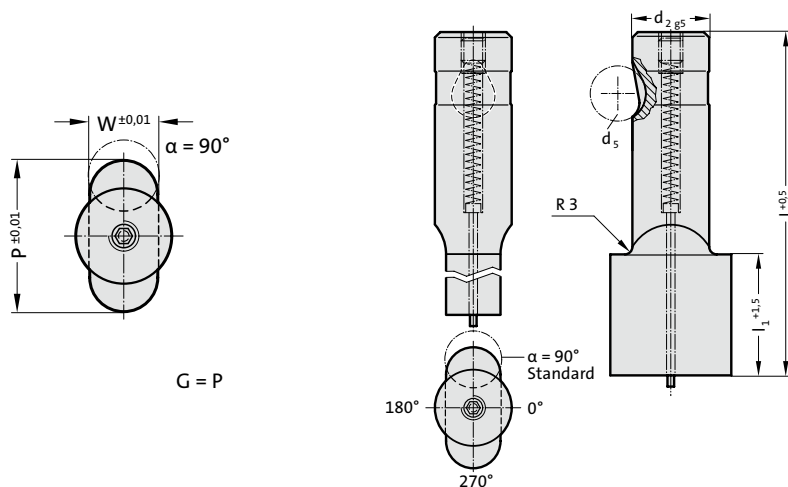

2745. Ball-Lock punch, punch larger than shaft, slot, with ejector pin, heavy duty

d ₂ / Order No	d ₅	W _{min}	G _{max}	l ₁ / Order No	l (Order Code character)	80 (E)	90 (F)	100 (G)
13 / (3)	12	5	32	19 (2) 30 (4)		●	●	●
16 / (4)	12	6.5	38	19 (2) 30 (4)		●	●	●
20 / (5)	12	8	40	19 (2) 30 (4)		●	●	●
25 / (6)	12	10	44	19 (2) 30 (4)		●	●	●
32 / (7)	12	11.5	50	19 (2) 30 (4)		●	●	●
40 / (9)	12	14	56	19 (2) 30 (4)		●	●	●

Ordering Code (example):

2745.7F2.3720.1150.B

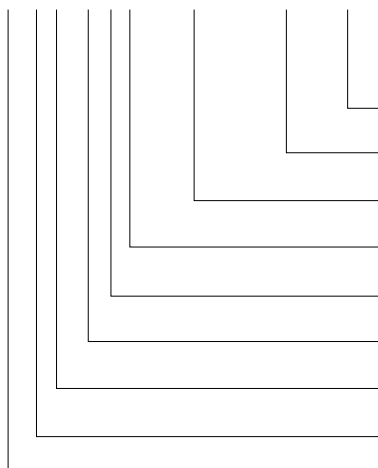

Angle:
90°
Shape: slot, Width W
W = 11,5 mm
Shape: slot, Length P
P = 37,2 mm
Punch cutting length: l₁
19 mm
Length: l
90 mm
Diameter: d₂
32 mm
Type:
punch larger, heavy
Execution:
slot
Punch:
with ejector pin

Order Code character
= (B)
= 1150
= 3720
Order No
= (2)
Order Code character
= (F)
Order No
= (7)
Order No
= (5)
Order No
= (4)
= 27

Material:

HSS
Hardness 62 ± 2 HRC

Execution:

Shaft and punch shape fine ground.
Special dimensions on request.

BALL-LOCK PUNCH, PUNCH LARGER THAN SHAFT, RECTANGLE WITH RADIUSSED CORNERS, WITH EJECTOR PIN, HEAVY DUTY



2755.

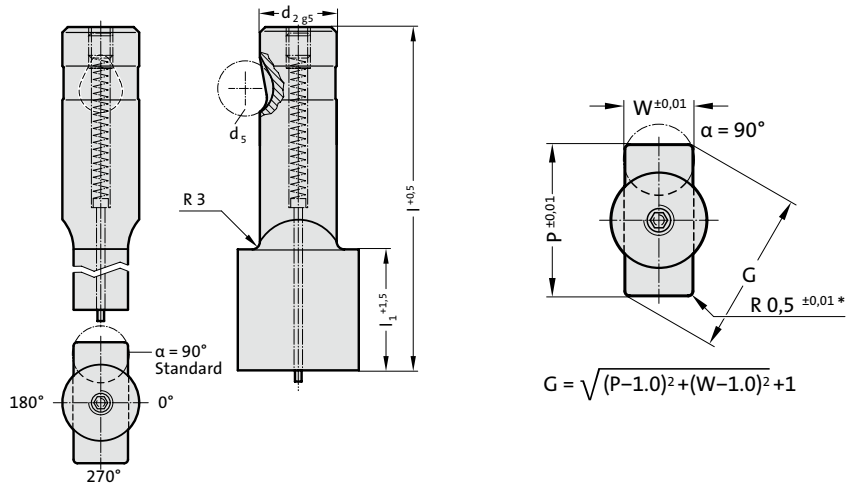

2755. Ball-Lock punch, punch larger than shaft, rectangle with radiussed corners, with ejector pin, heavy duty

d ₂ / Order No	d ₅	W _{min}	G _{max}	l ₁ / Order No	l (Order Code character)	80 (E)	90 (F)	100 (G)
13 / (3)	12	5	32	19 (2) 30 (4)		●	●	●
16 / (4)	12	6.5	38	19 (2) 30 (4)		●	●	●
20 / (5)	12	8	40	19 (2) 30 (4)		●	●	●
25 / (6)	12	10	44	19 (2) 30 (4)		●	●	●
32 / (7)	12	11.5	50	19 (2) 30 (4)		●	●	●
40 / (9)	12	14	56	19 (2) 30 (4)		●	●	●

Material:

HSS

Hardness 62 ± 2 HRC

Execution:

Shaft and punch shape fine ground.

Special dimensions on request.

* For other radius options, see standardised special shapes.

Ordering Code (example):

2755.3F2.1215.1150.B

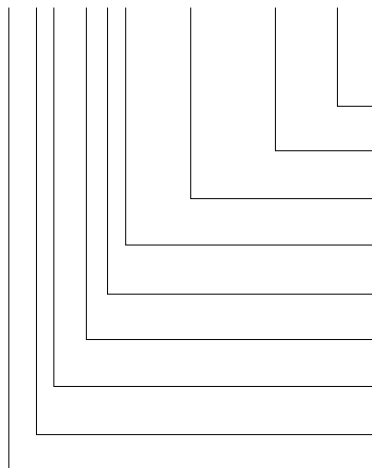

Angle:

90°

Shape: rectangle with radiused corners, Width W

W = 11,5 mm

Shape: rectangle with radiused corners, Length P

P = 12,15 mm

Punch cutting length: l₁

19 mm

Length: l

90 mm

Diameter: d₂

13 mm

Type:

punch larger, heavy

Execution:

rectangle with radiused corners

Punch:

with ejector pin

Order Code character

= (B)

= 1150

= 1215

= (2)

= (F)

= (3)

= (5)

= (5)

= (5)

= (5)

= (5)

= (5)

= (5)

= (5)

= (5)

= 27

BALL-LOCK PILOT PIN, WITH TAPERED TIP, HEAVY DUTY

2263.

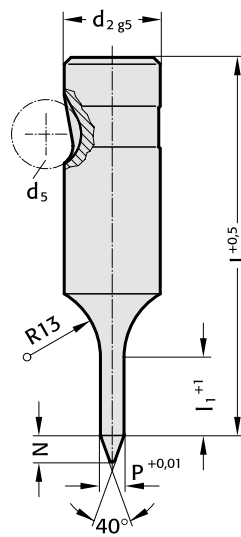

2263. Ball-Lock pilot pin, with tapered tip, heavy duty

d ₂ / Order No	d ₅	P	l ₁ / Order No	N	l (Order Code character)	71 (D)	80 (E)	90 (F)	100 (G)	110 (H)	125 (J)	140 (K)	150 (L)
10 / (2)	10	5,9 - 9,9	19 (2)	8		●	●	●	●	●			
13 / (3)	12	9,9 - 12,9	19 (2)	10		●	●	●	●	●	●		
16 / (4)	12	12,9 - 15,9	25 (3)	15		●	●	●	●	●	●	●	●
20 / (5)	12	15,9 - 19,9	25 (3)	20		●	●	●	●	●	●	●	●
25 / (6)	12	19,9 - 24,9	25 (3)	25			●	●	●	●	●	●	●
32 / (7)	12	24,9 - 31,9	25 (3)	30			●	●	●	●	●	●	●
40 / (9)	12	31,9 - 39,9	30 (4)	40			●	●	●	●	●	●	●

Ordering Code (example):

2263.4G3.1410

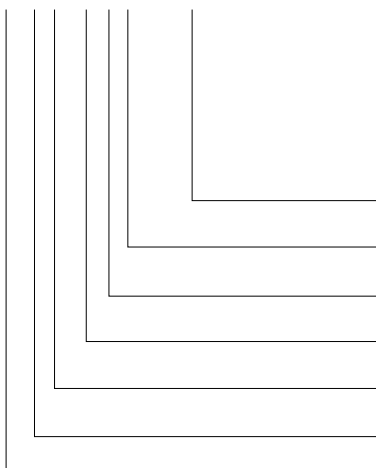

Shape: round
 P = Ø 14,1 mm = 1410
Punch cutting length: l₁
 25 mm = (3) **Order No**
Length: l
 100 mm = (G) **Order Code character**
Diameter: d₂
 16 mm = (4) **Order No**
Type:
 heavy = (3) **Order No**
Execution:
 Pilot pin with tapered tip = (6) **Order No**
Punch:
 without ejector pin = 22

Material:

HSS
 Hardness 62 ± 2 HRC

Execution:

Shaft and pilot pin fine ground.
 Special dimensions on request.

BALL-LOCK PILOT PIN, WITH PARABOLIC TIP, HEAVY DUTY



2273.

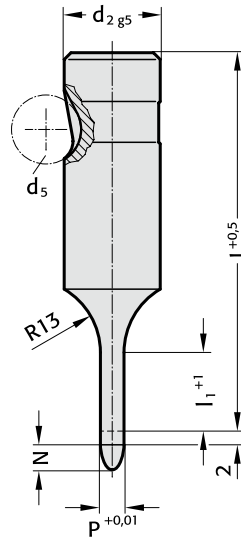

2273. Ball-Lock pilot pin, with parabolic tip, heavy duty

d ₂ / Order No	d ₅	P	l ₁ / Order No	l (Order Code character)	63 (C)	71 (D)	80 (E)	90 (F)	100 (G)	110 (H)	125 (J)
10 / (2)	10	5,9 - 9,9	19 (2)		●	●	●	●	●		
13 / (3)	12	9,9 - 12,9	19 (2)		●	●	●	●	●	●	●
16 / (4)	12	12,9 - 15,9	25 (3)		●	●	●	●	●	●	●
20 / (5)	12	15,9 - 19,9	25 (3)		●	●	●	●	●	●	●
25 / (6)	12	19,9 - 24,9	25 (3)		●	●	●	●	●	●	●
32 / (7)	12	24,9 - 31,9	25 (3)			●	●	●	●	●	●
40 / (9)	12	31,9 - 39,9	30 (4)				●	●	●	●	●

Material:

HSS

Hardness 62 ± 2 HRC

Execution:

Shaft and pilot pin fine ground.
Special dimensions on request.

Note:

The 2 mm length provides full guidance before the blanking punch contacts the sheet metal.

Length of parabolic tip N:

= 8 mm where P ≤ 10 mm

=12 mm where P 10,1 mm - 15 mm

=15 mm where P > 15 mm

Ordering Code (example):

2273.4G3.1410

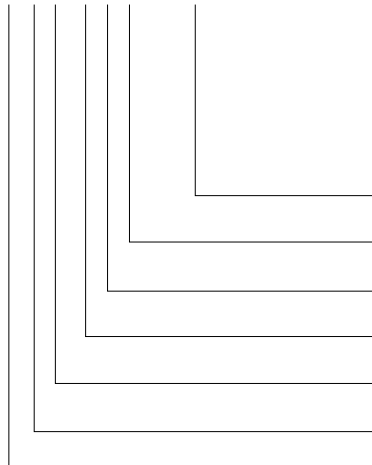

Shape: round

P = Ø 14,1 mm

Punch cutting length: l₁

25 mm

Length: l

100 mm

Diameter: d₂

16 mm

Type:

heavy

Execution:

Pilot pin with parabolic tip

Punch:

without ejector pin

= 1410

Order No

= (3)

Order Code character

= (G)

Order No

= (4)

Order No

= (3)

Order No

= (7)

= 22

PUNCHES BOLT LOCK

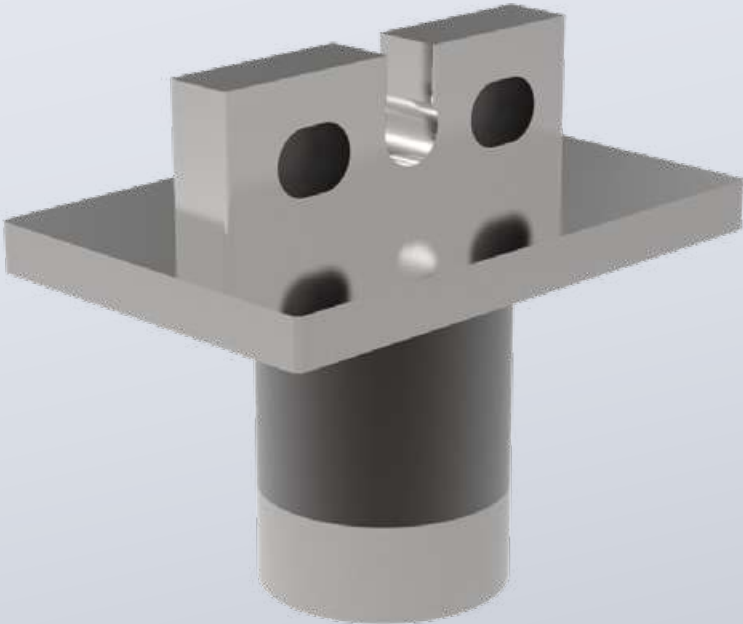

PUNCHES AND RETAINERS BOLT LOCK

The development of the BOLT LOCK system is a logical continuation of today's quick-release systems for punches beyond a shaft diameter of 40 mm.

Since the punches are available for any geometries, the compact system can be used for a variety of applications. An example of this is the use of punches to cut sheet metal parts, which are not manufactured as individual parts, but rather mainly as multiple parts for economic reasons. Large perforations in structured parts of the car body can be manufactured without a problem using the system.

In the area of follow-on composites, the system can also be used to cut the grating or remove the pc board. The system makes a valuable contribution to the further standardisation of tools and connected advantages in regard to time, costs and quality.

- Designed as a replacement for today's serially produced parts previously manufactured individually.
- Punches available in standard shapes and customer-specific special shapes according to data record.
- High quality due to automated serial production.
- Cost savings in design due to CAD standard parts library. Data in the currently common data formats can be called worldwide directly through fibro.partcommunity.com and is thus always up-to-date free of cost.
- Low spatial requirement as conventional system and therefore also an option for saving operations.
- Geometrical changes of the cutting contour do not affect the retaining plate, thus permitting cost savings in case of changes.
- Low mounting effort in tool maintenance, quick-release system.
- Punches are provided with extraction thread in the standard version. Lateral borehole in the case of cutting form width $W < 20$ mm.

BOLT LOCK PUNCHES - EXAMPLE ORDERS

Note: See table for standard dimensions
Special dimensions to order

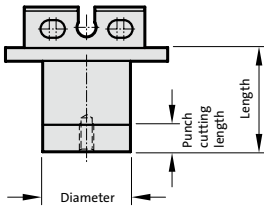

2 2 4 7 . 2 3 E 2 . 1 0 0 0 0 . 0 3 0 0 0 Z

Punch
22 without ejector pin

Execution:	Order No
○ blank	= 0**
⊙ round	= 1*
□ square	= 2*
▭ rectangular	= 3
○ slot	= 4
▭ rectangle with radiused corners	= 5

*only for size (a x b): 01, 04, 05

**only available as CAD download

Note:

Special forms available upon customer's request.

Use blank 2207. for CAD data,

(see fibro.partcommunity.com).

Type:	Order No
BOLT LOCK	= 7

Punch cutting length: l_1	Order No
20	= 2

Length: l	Order Code character
77	= E

Shape: Slot
Length P = 100 mm

Shape: Slot
Width W = 30 mm

optional: with retaining plate BOLT LOCK	Order Code character
	= Z

Size (a ₁ x b ₁):	Order No
01 (80 x 55)	= 1
02 (100 x 40)	= 2
03 (160 x 40)	= 3
04 (120 x 80)	= 4
05 (160 x 120)	= 5
06 (240 x 45)	= 6

Material:	Order No
HWS (1.2379)	= 2

other materials and coatings available upon request

Ordering Code (example):

2 2 4 7 . 2 3 E 2 . 1 0 0 0 0 . 0 3 0 0 0 Z

optional: with retaining plate BOLT LOCK (Z)

Shape: Slot, width W = 30 mm (03000)

Shape: Slot, length P = 100 mm (10000)

Punch cutting length: l_1 = 20 mm (2)

Length: l = 77 mm (E)

Size 03 (a₁ x b₁ = 160 x 40 mm) (3)

Material: HWS (1.2379) = (2)

Typ: BOLT LOCK (7)

Version: Slot (4)

Punch without ejector pin (22)

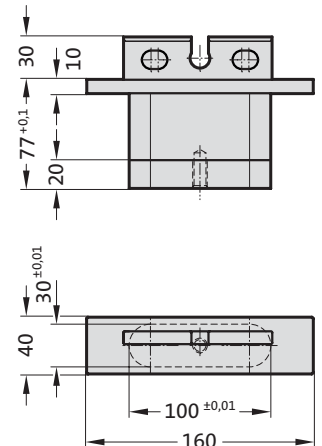

SPECIAL VERSION PUNCH BOLT LOCK

BOLT LOCK punches, can be designed with individual punch contours.
For this purpose, blanks are available as starting models.

In this starting model, the corresponding cutting contour can be imported using the CAD system after download and preferably sent to FIBRO in STEP format.
Six sizes are available on the download portal:

In the selection, the max. dimensions X,Y of the punch form apply as the limit.

Example:

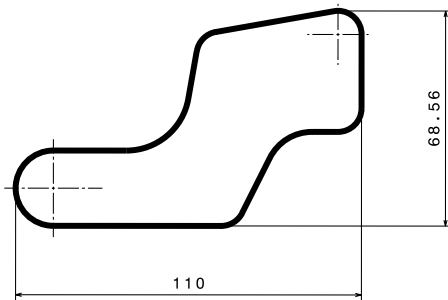

customer-specific cutting contour - max. dimensions of 110 x 69 mm



Selection of punch BOLT LOCK, blank according to the max. dimensions of the cutting form
Size 04 (A1 x B1 : 120 x 80 mm)

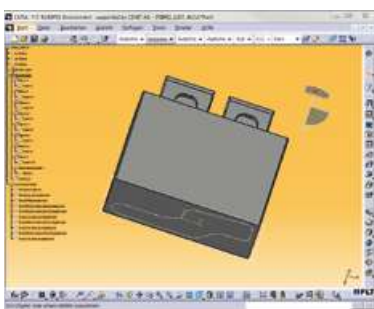

Download of model in desired CAD format (e.g.: STEP, CATIA, etc.)

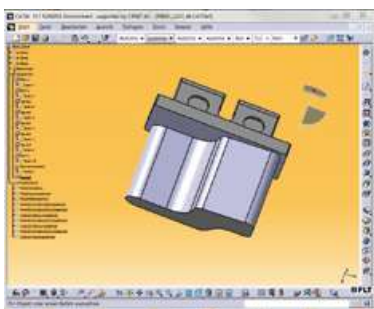

Incorporation of the cutting contour into the punch BOLT LOCK blank model.
Send the data to FIBRO in STEP format.

PUNCH BOLT LOCK, BLANK



2207.

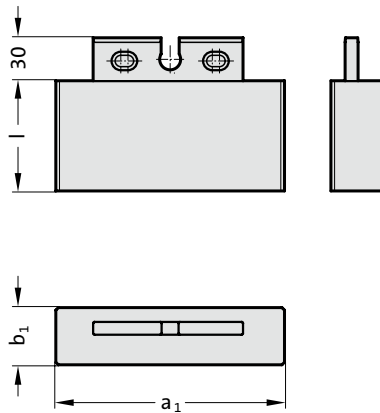

2207. Punch BOLT LOCK, blank

Size / (Order No)	a_1	b_1	l / (Order Code character)
01 / (1)	80	55	77 / (E)
02 / (2)	100	40	77 / (E)
03 / (3)	160	40	77 / (E)
04 / (4)	120	80	77 / (E)
05 / (5)	160	120	77 / (E)
06 / (6)	240	45	77 / (E)

Material:

HWS (1.2379)

Hardness 60 +2 HRC

Other materials upon request.

 Description of FIBRO materials for tool and die components see at the beginning of Chapter E.

Note:

BOLT LOCK punches, blank, cannot be ordered. They are used only for customer-specific cutting contours/special designs.

PUNCH BOLT LOCK, ROUND

Mounting example

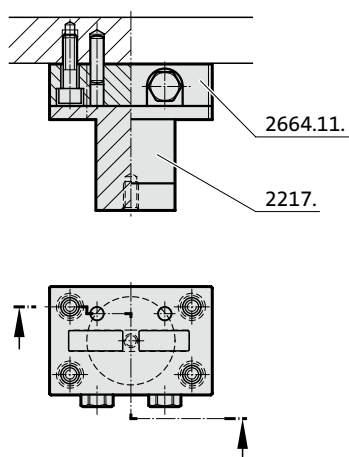

2217.

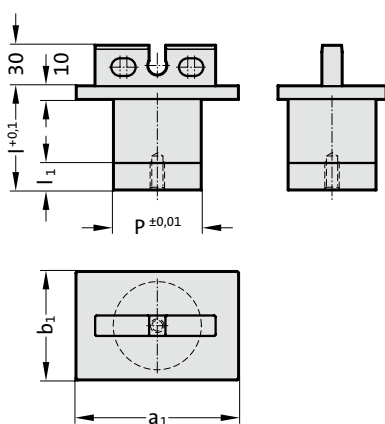

2217. Punch BOLT LOCK, round

Size / (Order No)	a ₁	b ₁	P _{min}	P _{max}	l ₁ / Order No	l / (Order Code character)
01 / (1)	80	55	35	54.9	20 / (E)	77 / (E)
04 / (4)	120	80	50	79.9	20 / (E)	77 / (E)
05 / (5)	160	120	75	119.9	20 / (E)	77 / (E)

Ordering Code (example):

2217.21E2.05000

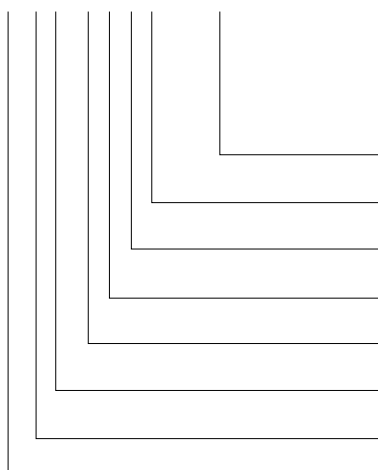

Shape: round
P = Ø 50 mm
Punch cutting length: l₁
20 mm
Length: l
77 mm
Size:
01 (a₁ x b₁; 80 x 55 mm)
Material:
HWS (1.2379)
Type:
BOLT LOCK
Execution:
round
Punch:
without ejector pin

= 05000
Order No
= (2)
Order Code character
= (E)
Order No
= (1)
Order No
= (2)
Order No
= (7)
Order No
= (1)
= 22

Material:

HWS (1.2379)
Hardness 60 +2 HRC

Other materials upon request.

Description of FIBRO materials for tool and die components see at the beginning of Chapter E.

Execution:

BOLT LOCK punches, round, are provided with an extraction thread (M10).

Note:

Order number for punch BOLT LOCK, round with retaining plate BOLT LOCK, including screws and pins:
2217.2□E2.□□□□□□□

PUNCH BOLT LOCK, SQUARE



2227.

Mounting example

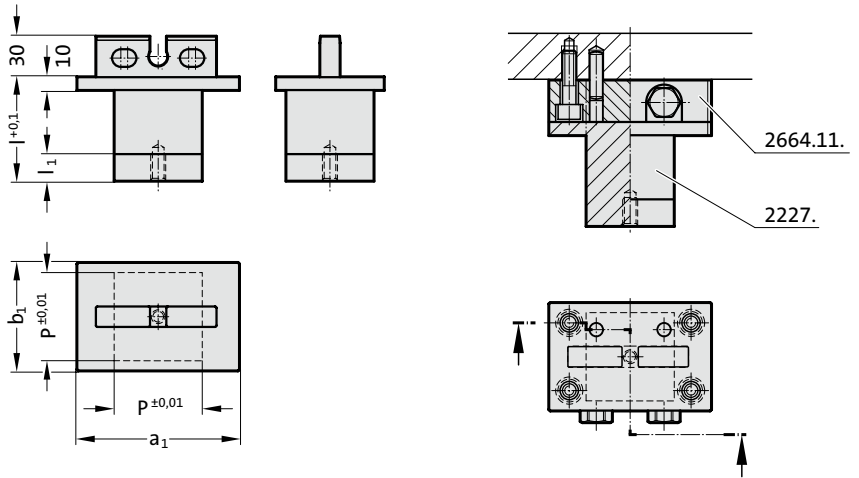

2227. Punch BOLT LOCK, square

Size / (Order No)	a ₁	b ₁	P _{min}	P _{max}	l ₁ / Order No	l / (Order Code character)
01 / (1)	80	55	35	54.9	20 / (E)	77 / (E)
04 / (4)	120	80	50	79.9	20 / (E)	77 / (E)
05 / (5)	160	120	75	119.9	20 / (E)	77 / (E)

Material:

HWS (1.2379)

Hardness 60 +2 HRC

Other materials upon request.

Description of FIBRO materials for tool and die components see at the beginning of Chapter E.

Execution:

BOLT LOCK punches, square, are provided with an extraction thread (M10).

Note:

Order number for punch BOLT LOCK, square with retaining plate BOLT LOCK, including screws and pins:

2227.2□E2.□□□□□□Z

Ordering Code (example):

2227.21E2.04050

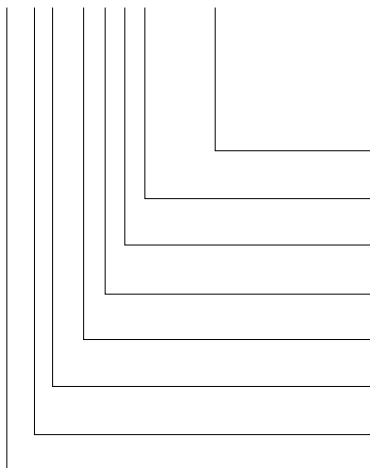

Shape: square , Length P

P = 40,5 mm

Punch cutting length: l₁

20 mm

Length: l

77 mm

Size:

01 (a₁ x b₁: 80 x 55 mm)

Material:

HWS (1.2379)

Type:

BOLT LOCK

Execution:

square

Punch:

without ejector pin

= 04050

Order No

= (2)

Order Code character

= (E)

Order No

= (1)

Order No

= (2)

Order No

= (7)

Order No

= (2)

= 22

PUNCH BOLT LOCK, RECTANGULAR

Mounting example

2237.

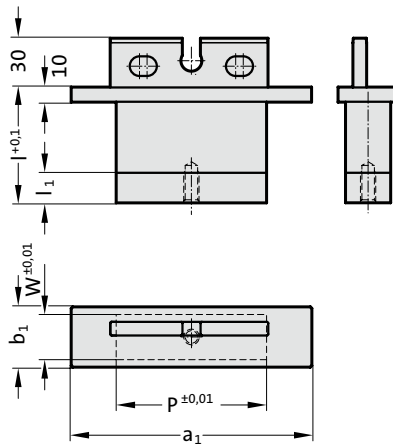
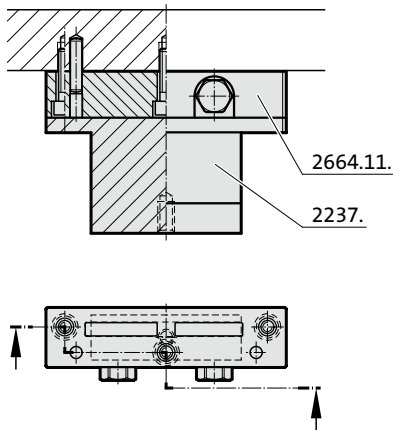

2237. Punch BOLT LOCK, rectangular

Size / (Order No)	a ₁	b ₁	P _{min}	P _{max}	W _{min}	W _{max}	l ₁ / Order No	l / (Order Code character)
01 / (1)	80	55	55	79.9	10	54.9	20 / (E)	77 / (E)
02 / (2)	100	40	40	99.9	10	39.9	20 / (E)	77 / (E)
03 / (3)	160	40	40	159.9	10	39.9	20 / (E)	77 / (E)
04 / (4)	120	80	80	119.9	10	79.9	20 / (E)	77 / (E)
05 / (5)	160	120	120	159.9	10	119.9	20 / (E)	77 / (E)
06 / (6)	240	45	45	239.9	10	44.9	20 / (E)	77 / (E)

Ordering Code (example):

2237.21E2.07050.04550

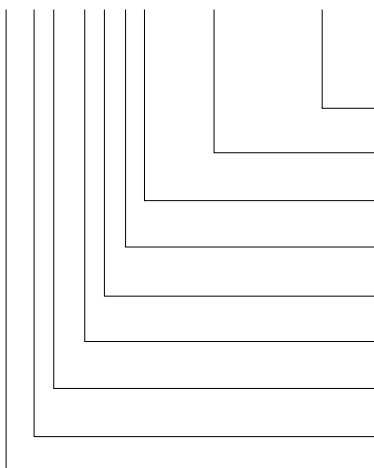

- Shape: rectangular, Width W**
W = 45,5 mm = 04550
- Shape: rectangular, Length P**
P = 70,5 mm = 07050
- Punch cutting length: l₁**
20 mm = (2)
- Length: l**
77 mm = (E)
- Size:**
01 (a₁ x b₁: 80 x 55 mm) = (1)
- Material:**
HWS (1.2379) = (2)
- Type:**
BOLT LOCK = (7)
- Execution:**
rectangular = (3)
- Punch:**
without ejector pin = 22

Material:

HWS (1.2379)
Hardness 60 +2 HRC

Other materials upon request.

Description of FIBRO materials for tool and die components see at the beginning of Chapter E.

Execution:

BOLT LOCK punches, rectangle, are provided with an extraction thread (M10).
For cutting form width W < 20 mm, the punch is provided with a transverse bore (ø 10 mm).

Note:

Order number for punch BOLT LOCK, rectangle with retaining plate BOLT LOCK, including screws and pins:
2237.21E2.000000.000000Z

PUNCH BOLT LOCK, SLOT



2247.

Mounting example

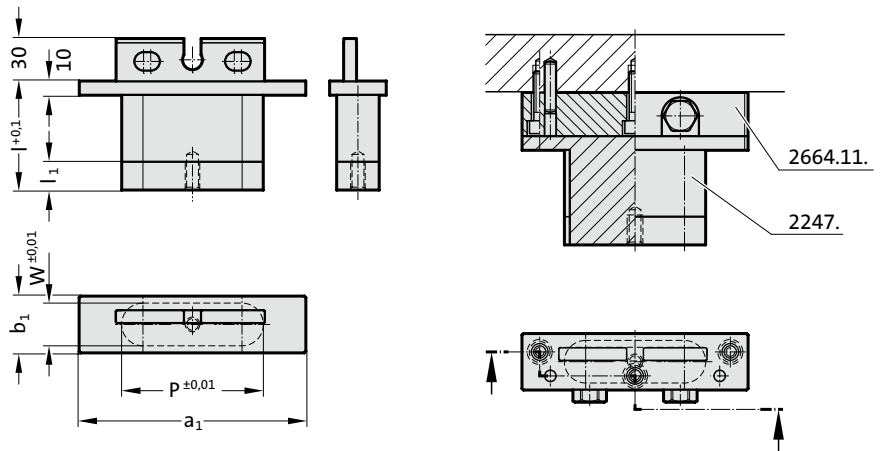

2247. Punch BOLT LOCK, slot

Size / (Order No)	a ₁	b ₁	P _{min}	P _{max}	W _{min}	W _{max}	l ₁ / Order No	l / (Order Code character)
01 / (1)	80	55	55	79.9	10	54.9	20 / (E)	77 / (E)
02 / (2)	100	40	40	99.9	10	39.9	20 / (E)	77 / (E)
03 / (3)	160	40	40	159.9	10	39.9	20 / (E)	77 / (E)
04 / (4)	120	80	80	119.9	10	79.9	20 / (E)	77 / (E)
05 / (5)	160	120	120	159.9	10	119.9	20 / (E)	77 / (E)
06 / (6)	240	45	45	239.9	10	44.9	20 / (E)	77 / (E)

Material:

HWS (1.2379)

Hardness 60 +2 HRC

Other materials upon request.

Description of FIBRO materials for tool and die components see at the beginning of Chapter E.

Execution:

BOLT LOCK punches with an slot are provided with an extraction thread (M10).

For cutting form width $W < 20$ mm, the punch is provided with a transverse bore (ϕ 10 mm).

Note:

Order number for punch BOLT LOCK, slot with retaining plate BOLT LOCK, including screws and pins:

2247.20E2.000000.00000Z

Ordering Code (example):

2247.21E2.07050.04550

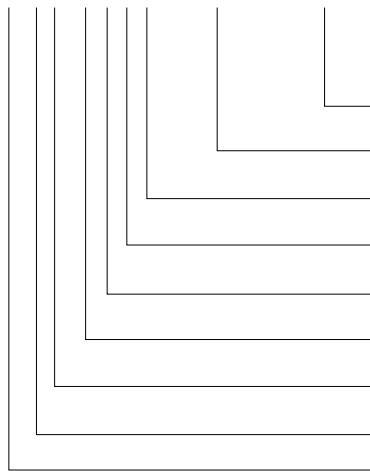

Shape: slot, Width W

W = 45,5 mm

= 04550

Shape: slot, Length P

P = 70,5 mm

= 07050

Punch cutting length: l₁

20 mm

= 20

Length: l

77 mm

= (E)

Size:

01 (a₁ x b₁: 80 x 55 mm)

= (1)

Material:

HWS (1.2379)

= (2)

Type:

BOLT LOCK

= (7)

Execution:

slot

= (7)

Punch:

without ejector pin

= (4)

= 22

PUNCH BOLT LOCK, RECTANGLE WITH RADIUSED CORNERS

Mounting example

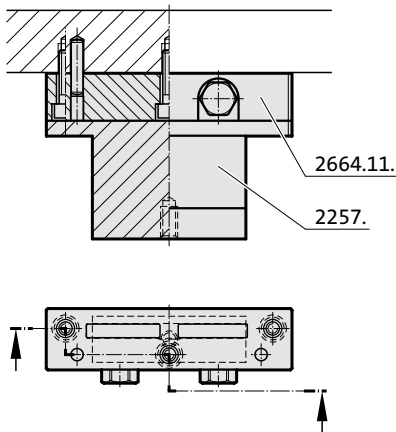

2257.

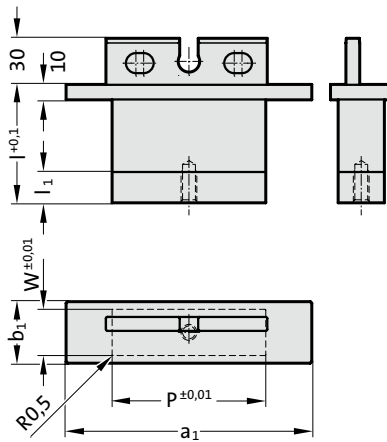

2257. Punch BOLT LOCK, rectangle with radiused corners

Size / (Order No)	a_1	b_1	P_{\min}	P_{\max}	W_{\min}	W_{\max}	I_1 / Order No	I / (Order Code character)
01 / (1)	80	55	55	79.9	10	54.9	20 / (E)	77 / (E)
02 / (2)	100	40	40	99.9	10	39.9	20 / (E)	77 / (E)
03 / (3)	160	40	40	159.9	10	39.9	20 / (E)	77 / (E)
04 / (4)	120	80	80	119.9	10	79.9	20 / (E)	77 / (E)
05 / (5)	160	120	120	159.9	10	119.9	20 / (E)	77 / (E)
06 / (6)	240	45	45	239.9	10	44.9	20 / (E)	77 / (E)

Ordering Code (example):

2257.21E2.07050.04550

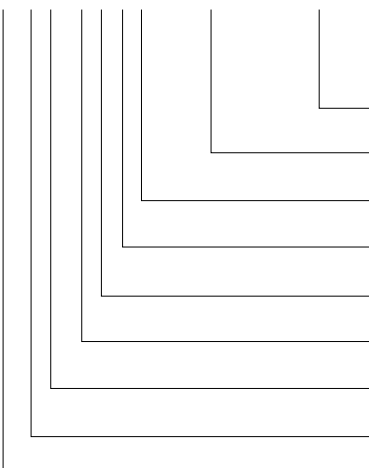

Shape: rectangle with radiused corners, Width W
 $W = 45,5 \text{ mm}$ = 04550
Shape: rectangle with radiused corners, Length P
 $P = 70,5 \text{ mm}$ = 07050
Punch cutting length: I_1
 20 mm = (2)
Length: I
 77 mm = (E)
Size:
 $01 (a_1 \times b_1: 80 \times 55 \text{ mm})$ = (1)
Material:
 HWS (1.2379) = (2)
Type:
 BOLT LOCK = (7)
Execution:
 rectangle with radiused corners = (5)
Punch:
 without ejector pin = 22

Material:

HWS (1.2379)

Hardness 60 +2 HRC

Other materials upon request.

☞ Description of FIBRO materials for tool and die components see at the beginning of Chapter E.

Execution:

BOLT LOCK punches, rectangle with radius, are provided with an extraction thread (M10). For cutting form width $W < 20 \text{ mm}$, the punch is provided with a transverse bore ($\varnothing 10 \text{ mm}$).

Note:

Order number for punch BOLT LOCK, rectangle with radius and retaining plate BOLT LOCK, including screws and pins:
 2257.21E2.000000.000000Z

PUNCHES ISO 8020



PUNCH ISO 8020 - EXAMPLE ORDERS

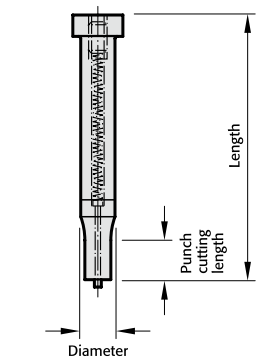

Note: See table for standard dimensions
Special dimensions to order

2 2 4 1 . 7 G 4 . 0 6 5 0 . 0 4 5 0 . A

Punch:
22 without ejector pin
27 with ejector pin

Execution:	Order No
○ blank	= 0
⊙ round	= 1
□ square	= 2
▭ rectangular	= 3
⊔ slot	= 4
▭ rectangle with radiused corners	= 5
▽ Pilot pin with tapered tip	= 6
⊔ Pilot pin parabolic tip	= 7
special shapes	= 9

Type:	Order No
ISO	= 1

Punch cutting length: l_1	Order No
8	= 1
10	= 2
13	= 3
19	= 4
25	= 5
30	= 6
special	= X

Format: Slot
length P = 6.5 mm

Form: slot
width = 4.5 mm

Angle:	Order Code character
0°	= A
90°	= B
180°	= C
270°	= D
special	= X

Length: l	Order Code character
-----------	----------------------

50	= A
56	= B
63	= C
71	= D
80	= E
90	= F
100	= G
110	= H
120	= J
125	= K
140	= L
150	= M
200	= N
special	= X

Diameter: d_1	Order No
3	= 1
4	= 2
5	= 3
6	= 4
8	= 5
10	= 6
13	= 7
16	= 8
20	= 9
25	= 10
32	= 11

Ordering Code (example):

2 2 4 1 . 7 G 4 . 0 6 5 0 . 0 4 5 0 . A

- Angle = 0° (A)
- Format: Slot, width W = 4.5 mm (0450)
- Format: Slot, length P = 6.5 mm (0650)
- Punch cutting length: l_1 = 19 mm (4)
- Length: l = 100 mm (G)
- Diameter: d_1 = 13 mm (7)
- Type: ISO (1)
- Version: Slot (4)
- Punch without ejector pin (22)

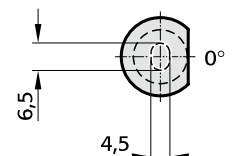
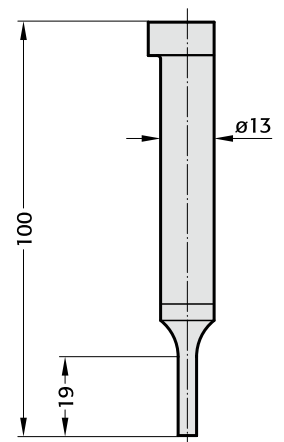

PUNCH, BLANK, ISO 8020

2201.

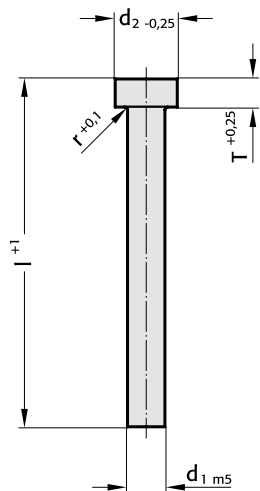

2201. Punch, blank, ISO 8020

d_1 / Order No	d_2	r	T	l / (Order Code character)	71 (D)	80 (E)	90 (F)	100 (G)	120 (J)	150 (M)	200 (N)
3 / (1)	5	0.25	3		●	●	●	●	●		
4 / (2)	6	0.25	3		●	●	●	●	●		
5 / (3)	8	0.3	5		●	●	●	●	●		
6 / (4)	9	0.3	5		●	●	●	●	●		
8 / (5)	11	0.3	5		●	●	●	●	●		
10 / (6)	13	0.3	5		●	●	●	●	●	●	
13 / (7)	16	0.4	5		●	●	●	●	●	●	
16 / (8)	19	0.4	5		●	●	●	●	●	●	●
20 / (9)	23	0.4	5		●	●	●	●	●	●	●
25 / (10)	28	0.4	5		●	●	●	●	●	●	●
32 / (11)	35	0.4	5		●	●	●	●	●	●	●

Ordering Code (example):

2201.7G.ASP

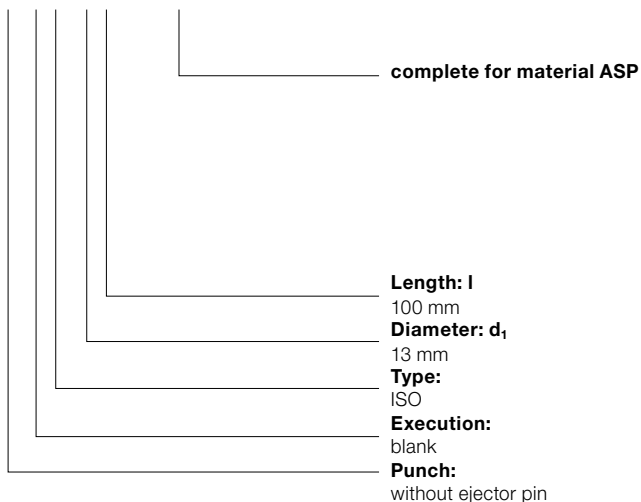

Material:

HSS
 Hardness:
 Shaft 64 ± 2 HRC
 Head 52 ± 5 HRC

ASP 23 - ASP 2023
 upon request

Description of FIBRO materials for tool and die components see at the beginning of Chapter E.

Execution:

Punch head hot upset-forged. Shoulder and shaft fine ground.
 Special dimensions on request.

PUNCH, STEPPED, ROUND, ISO 8020



2211.

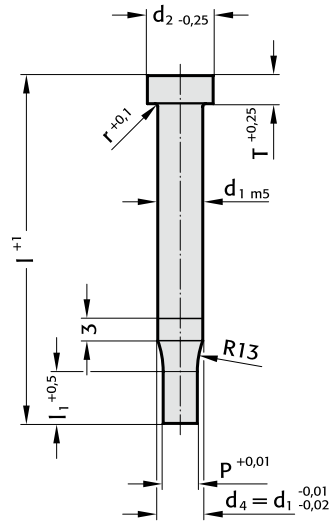

2211. Punch, stepped, round, ISO 8020

d ₁ / Order No	d ₂	P	I ₁ / Order No	r	T	I / (Order Code character)	71 (D)	80 (E)	90 (F)	100 (G)	120 (J)
3 / (1)	5	0,8 - 2,9	8 (1) 10 (2)	0,25	3		●	●	●	●	●
4 / (2)	6	1 - 3,9	8 (1) 13 (3)	0,25	3		●	●	●	●	●
5 / (3)	8	1,5 - 4,9	13 (3) 19 (4)	0,3	5		●	●	●	●	●
6 / (4)	9	1,6 - 5,9	13 (3) 19 (4)	0,3	5		●	●	●	●	●
8 / (5)	11	2,5 - 7,9	19 (4) 25 (5)	0,3	5		●	●	●	●	●
10 / (6)	13	4 - 9,9	19 (4) 25 (5)	0,3	5		●	●	●	●	●
13 / (7)	16	5 - 12,9	19 (4) 25 (5)	0,4	5		●	●	●	●	●
16 / (8)	19	8 - 15,9	19 (4) 25 (5)	0,4	5		●	●	●	●	●
20 / (9)	23	12 - 19,9	19 (4) 25 (5)	0,4	5		●	●	●	●	●
25 / (10)	28	16,5 - 24,9	19 (4) 25 (5)	0,4	5		●	●	●	●	●
32 / (11)	35	20 - 31,9	25 (5) 30 (6)	0,4	5		●	●	●	●	●

Material:

HSS

Hardness:

Shaft 64 ± 2 HRC

Head 52 ± 5 HRC

ASP 23 - ASP 2023

upon request

Description of FIBRO materials for tool and die components see at the beginning of Chapter E.

Execution:

Punch head hot upset-forged. Shoulder, shaft and punch diameter fine ground.

Special dimensions on request.

Ordering Code (example):

2211.7G4.0720

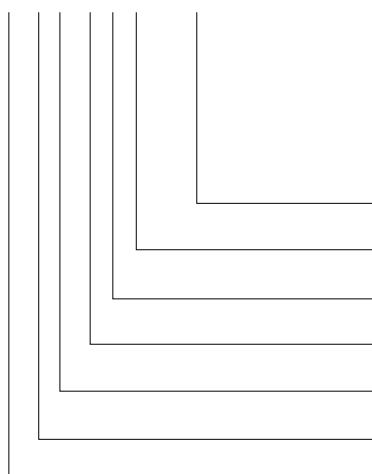

Shape: round

P = Ø 7,2 mm

Punch cutting length: I₁

19 mm

Length: I

100 mm

Diameter: d₁

13 mm

Type:

ISO

Execution:

round

Punch:

without ejector pin

= 0720

Order No

= (4)

Order Code character

= (G)

Order No

= (7)

Order No

= (1)

Order No

= (1)

= 22

PUNCH, STEPPED, SQUARE, ISO 8020

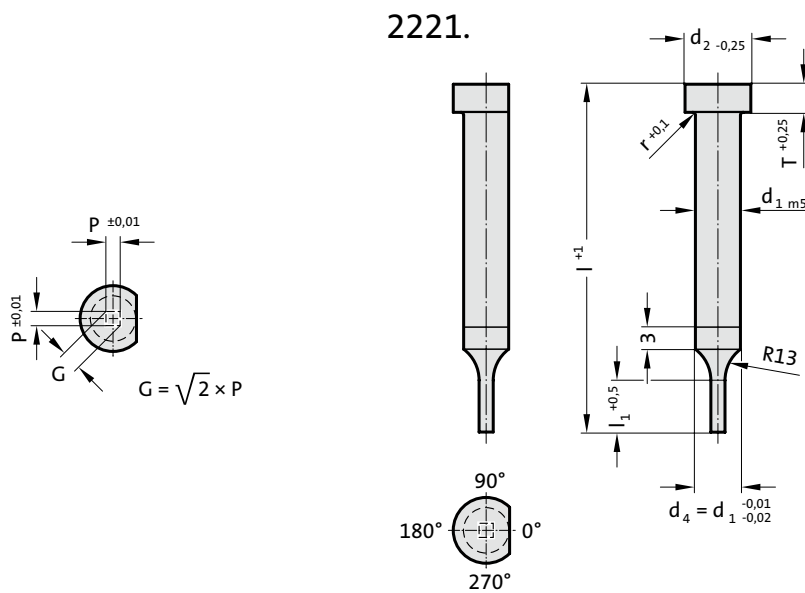

2221. Punch, stepped, square, ISO 8020

d ₁ / Order No	d ₂	P _{min}	G _{max}	l ₁ / Order No	r	T	l / (Order Code character)	71 (D)	80 (E)	90 (F)	100 (G)	120 (J)
3 / (1)	5	0.5	2.9	8 (1) 10 (2)	0.25	3		●	●	●	●	●
4 / (2)	6	0.8	3.9	8 (1) 13 (3)	0.25	3		●	●	●	●	●
5 / (3)	8	1	4.9	13 (3) 19 (4)	0.3	5		●	●	●	●	●
6 / (4)	9	1.6	5.9	13 (3) 19 (4)	0.3	5		●	●	●	●	●
8 / (5)	11	2	7.9	19 (4) 25 (5)	0.3	5		●	●	●	●	●
10 / (6)	13	3.5	9.9	19 (4) 25 (5)	0.3	5		●	●	●	●	●
13 / (7)	16	4.5	12.9	19 (4) 25 (5)	0.4	5		●	●	●	●	●
16 / (8)	19	6	15.9	19 (4) 25 (5)	0.4	5		●	●	●	●	●
20 / (9)	23	8	19.9	19 (4) 25 (5)	0.4	5		●	●	●	●	●
25 / (10)	28	10	24.9	19 (4) 25 (5)	0.4	5		●	●	●	●	●
32 / (11)	35	10	31.9	25 (5) 30 (6)	0.4	5		●	●	●	●	●

Ordering Code (example):

2221.9E5.1550.B

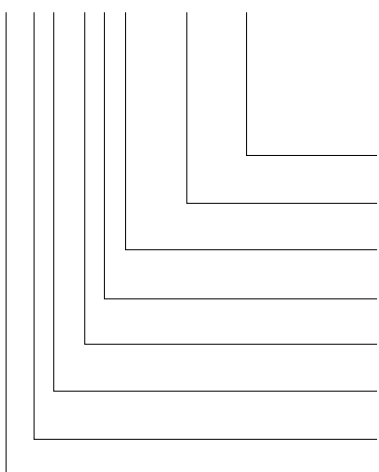

Angle:
90°
Shape: square, Length P
P = 15,5 mm
Punch cutting length: l₁
25 mm
Length: l
80 mm
Diameter: d₁
20 mm
Type:
ISO
Execution:
square
Punch:
without ejector pin

Order Code character
= (B)
Order No
= 1550
Order Code character
= (E)
Order No
= (9)
Order No
= (1)
Order No
= (2)
Order No
= 22

Material:

HSS
Hardness:
Shaft 64 ± 2 HRC
Head 52 ± 5 HRC

ASP 23 - ASP 2023

upon request

☞ Description of FIBRO materials for tool and die components see at the beginning of Chapter E.

Execution:

Punch head hot upset-forged. Shoulder, shaft and punch shape fine ground.

The anti-rotation surface parallel to P = 0° as standard.

Special dimensions on request.

Note:

With kerf ≤ 0.04 mm, FIBRO rounds off sharp edges if the punch and piercing die bush are ordered together. This reduces the fitting time and the risk of an edge break during operation.

PUNCH, STEPPED, RECTANGULAR, ISO 8020



2231.

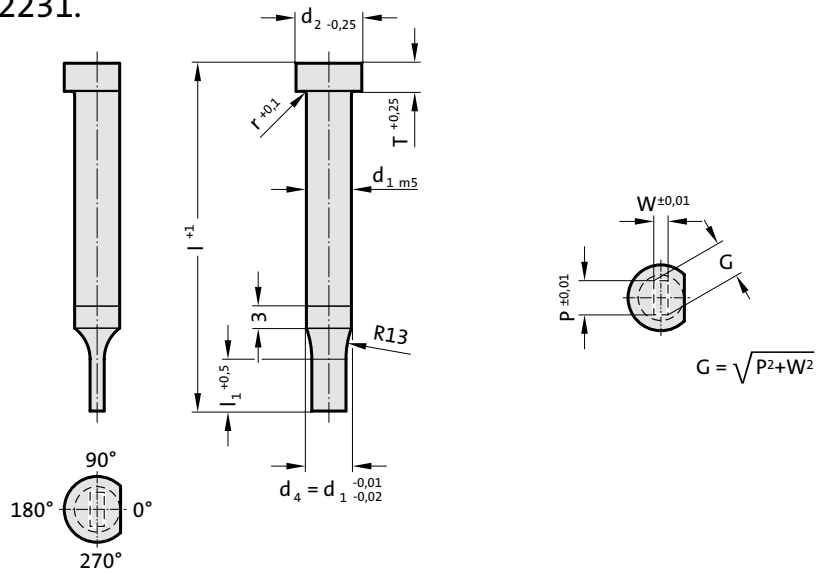

2231. Punch, stepped, rectangular, ISO 8020

d ₁ / Order No	d ₂	W _{min}	G _{max}	l ₁ / Order No	r	T	l / (Order Code character)	71 (D)	80 (E)	90 (F)	100 (G)	120 (J)
3 / (1)	5	0.5	2.9	8 (1) 10 (2)	0.25	3		●	●	●	●	●
4 / (2)	6	0.8	3.9	8 (1) 13 (3)	0.25	3		●	●	●	●	●
5 / (3)	8	1	4.9	13 (3) 19 (4)	0.3	5		●	●	●	●	●
6 / (4)	9	1.6	5.9	13 (3) 19 (4)	0.3	5		●	●	●	●	●
8 / (5)	11	2	7.9	19 (4) 25 (5)	0.3	5		●	●	●	●	●
10 / (6)	13	3.5	9.9	19 (4) 25 (5)	0.3	5		●	●	●	●	●
13 / (7)	16	4.5	12.9	19 (4) 25 (5)	0.4	5		●	●	●	●	●
16 / (8)	19	6	15.9	19 (4) 25 (5)	0.4	5		●	●	●	●	●
20 / (9)	23	8	19.9	19 (4) 25 (5)	0.4	5		●	●	●	●	●
25 / (10)	28	10	24.9	19 (4) 25 (5)	0.4	5		●	●	●	●	●
32 / (11)	35	10	31.9	25 (5) 30 (6)	0.4	5		●	●	●	●	●

Material:

HSS

Hardness:

Shaft 64 ± 2 HRC

Head 52 ± 5 HRC

ASP 23 - ASP 2023

upon request

Description of FIBRO materials for tool and die components see at the beginning of Chapter E.

Execution:

Punch head hot upset-forged. Shoulder, shaft and punch shape fine ground.

The anti-rotation surface parallel to P = 0° as standard.

Special dimensions on request.

Note:

With kerf ≤ 0.04 mm, FIBRO rounds off sharp edges if the punch and piercing die bush are ordered together. This reduces the fitting time and the risk of an edge break during operation.

Ordering Code (example):

2231.9F4.1550.1150.B

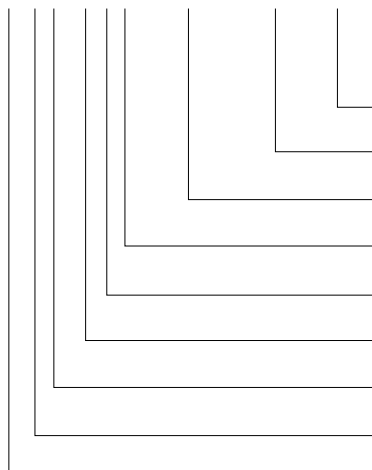

Angle:

90°

Shape: rectangular, Width W

W = 11,5 mm

Shape: rectangular, Length P

P = 15,5 mm

Punch cutting length: l₁

19 mm

Length: l

90 mm

Diameter: d₁

20 mm

Type:

ISO

Execution:

rectangular

Punch:

without ejector pin

Order Code character
= (B)

= 1150

= 1550

Order No

= (4)

Order Code character

= (F)

Order No

= (9)

Order No

= (1)

Order No

= (3)

= 22

PUNCH, STEPPED, SLOT, ISO 8020

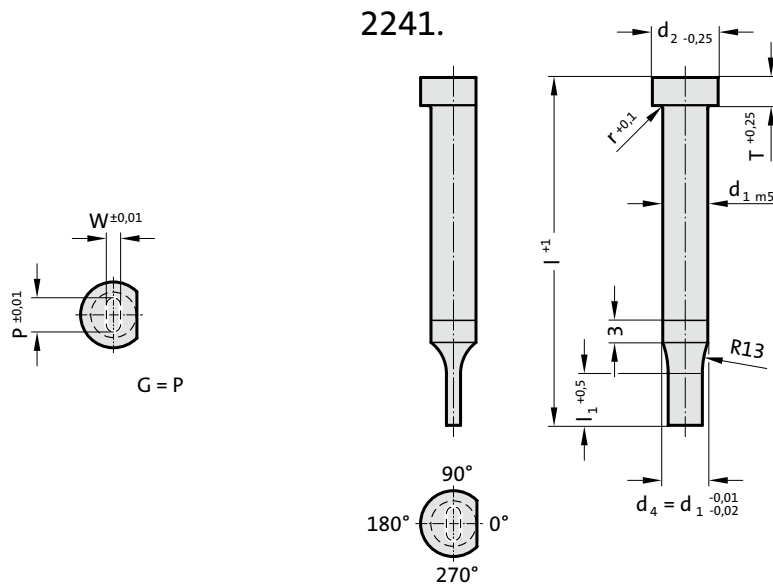

2241. Punch, stepped, slot, ISO 8020

d_1 / Order No	d_2	W_{min}	G_{max}	l_1 / Order No	r	T	l / (Order Code character)	71 (D)	80 (E)	90 (F)	100 (G)	120 (J)
3 / (1)	5	0.5	2.9	8 (1) 10 (2)	0.25	3		●	●	●	●	●
4 / (2)	6	0.8	3.9	8 (1) 13 (3)	0.25	3		●	●	●	●	●
5 / (3)	8	1	4.9	13 (3) 19 (4)	0.3	5		●	●	●	●	●
6 / (4)	9	1.6	5.9	13 (3) 19 (4)	0.3	5		●	●	●	●	●
8 / (5)	11	2	7.9	19 (4) 25 (5)	0.3	5		●	●	●	●	●
10 / (6)	13	3.5	9.9	19 (4) 25 (5)	0.3	5		●	●	●	●	●
13 / (7)	16	4.5	12.9	19 (4) 25 (5)	0.4	5		●	●	●	●	●
16 / (8)	19	6	15.9	19 (4) 25 (5)	0.4	5		●	●	●	●	●
20 / (9)	23	8	19.9	19 (4) 25 (5)	0.4	5		●	●	●	●	●
25 / (10)	28	10	24.9	19 (4) 25 (5)	0.4	5		●	●	●	●	●
32 / (11)	35	10	31.9	25 (5) 30 (6)	0.4	5		●	●	●	●	●

Ordering Code (example):

2241.9E5.1650.1220.B

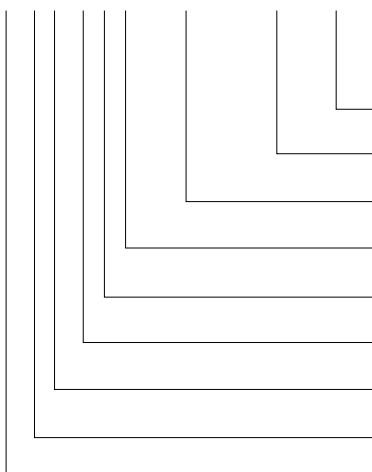

Angle:
90°
Shape: slot, Width W
W = 12,2 mm
Shape: slot, Length P
P = 16,5 mm
Punch cutting length: l_1
25 mm
Length: l
80 mm
Diameter: d_1
20 mm
Type:
ISO
Execution:
slot
Punch:
without ejector pin

Order Code character
= (B)
= 1220
= 1650
Order No
= (5)
Order Code character
= (E)
Order No
= (9)
Order No
= (1)
Order No
= (4)
= 22

Material:

HSS
Hardness:
Shaft 64 ± 2 HRC
Head 52 ± 5 HRC

ASP 23 - ASP 2023
upon request

Description of FIBRO materials for tool and die components see at the beginning of Chapter E.

Execution:

Punch head hot upset-forged. Shoulder, shaft and punch shape fine ground.
The anti-rotation surface parallel to $P = 0^\circ$ as standard.
Special dimensions on request.

PUNCH, STEPPED, RECTANGLE WITH RADIUSED CORNERS, ISO 8020



2251.

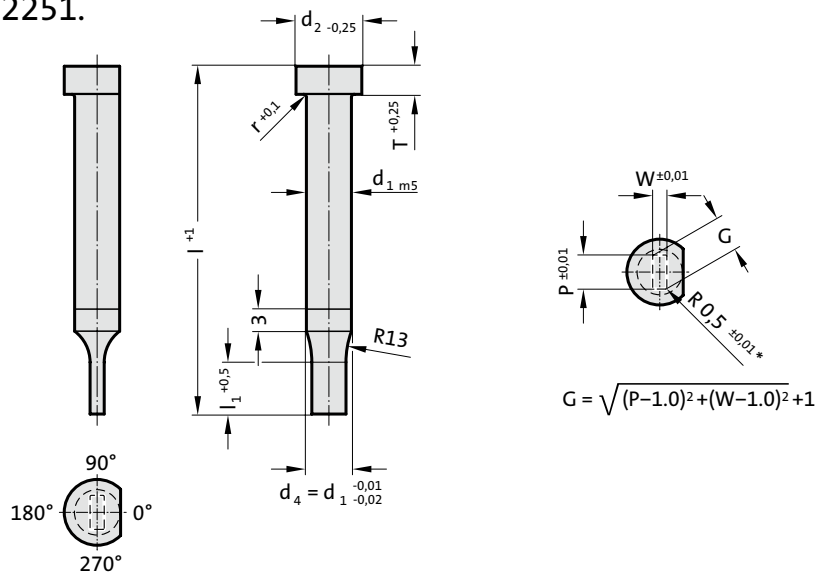

2251. Punch, stepped, rectangle with radiused corners, ISO 8020

d ₁ / Order No	d ₂	W _{min}	G _{max}	l ₁ / Order No	r	T	l / (Order Code character)	71 (D)	80 (E)	90 (F)	100 (G)	120 (J)
3 / (1)	5	1.1	2.9	8 (1) 10 (2)	0.25	3		●	●	●	●	●
4 / (2)	6	1.1	3.9	8 (1) 13 (3)	0.25	3		●	●	●	●	●
5 / (3)	8	1.1	4.9	13 (3) 19 (4)	0.3	5		●	●	●	●	●
6 / (4)	9	1.6	5.9	13 (3) 19 (4)	0.3	5		●	●	●	●	●
8 / (5)	11	2	7.9	19 (4) 25 (5)	0.3	5		●	●	●	●	●
10 / (6)	13	3.5	9.9	19 (4) 25 (5)	0.3	5		●	●	●	●	●
13 / (7)	16	4.5	12.9	19 (4) 25 (5)	0.4	5		●	●	●	●	●
16 / (8)	19	6	15.9	19 (4) 25 (5)	0.4	5		●	●	●	●	●
20 / (9)	23	8	19.9	19 (4) 25 (5)	0.4	5		●	●	●	●	●
25 / (10)	28	10	24.9	19 (4) 25 (5)	0.4	5		●	●	●	●	●
32 / (11)	35	10	31.9	25 (5) 30 (6)	0.4	5		●	●	●	●	●

Material:

HSS

Hardness:

Shaft 64 ± 2 HRC

Head 52 ± 5 HRC

ASP 23 - ASP 2023

upon request

☞ Description of FIBRO materials for tool and die components see at the beginning of Chapter E.

Execution:

Punch head hot upset-forged. Shoulder, shaft and punch shape fine ground.

The anti-rotation surface parallel to P = 0° as standard.

Special dimensions on request.

* For other radius options, see standardised special shapes.

Ordering Code (example):

2251.9F4.1215.1150.B

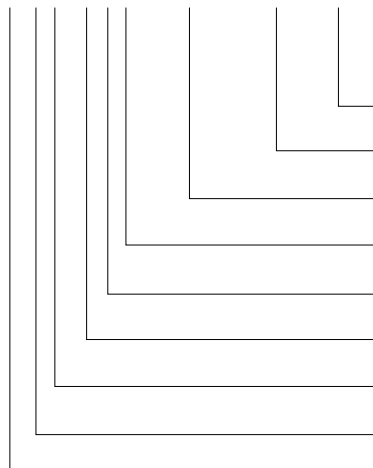

Angle:

90°

Shape: rectangle with radiused corners, Width W

W = 11,5 mm

Shape: rectangle with radiused corners, Length P

P = 12,15 mm

Punch cutting length: l₁

19 mm

Length: l

90 mm

Diameter: d₁

20 mm

Type:

ISO

Execution:

rectangle with radiused corners

Punch:

without ejector pin

Order Code character

= (B)

Order Code character

= 1150

Order Code character

= 1215

Order No

= (4)

Order Code character

= (F)

Order No

= (9)

Order No

= (1)

Order No

= (5)

= 22

PUNCH, BLANK, WITH EJECTOR PIN, ISO 8020

2701.

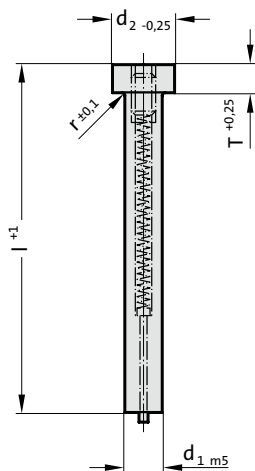

2701. Punch, blank, with ejector pin, ISO 8020

d ₁ / Order No	d ₂	r	T	l / (Order Code character)	71 (D)	80 (E)	90 (F)	100 (G)	120 (J)
5 / (3)	8	0.3	5		●	●	●	●	●
6 / (4)	9	0.3	5		●	●	●	●	●
8 / (5)	11	0.3	5		●	●	●	●	●
10 / (6)	13	0.3	5		●	●	●	●	●
13 / (7)	16	0.4	5		●	●	●	●	●
16 / (8)	19	0.4	5		●	●	●	●	●
20 / (9)	23	0.4	5		●	●	●	●	●
25 / (10)	28	0.4	5		●	●	●	●	●
32 / (11)	35	0.4	5		●	●	●	●	●

Ordering Code (example):

2701.8G

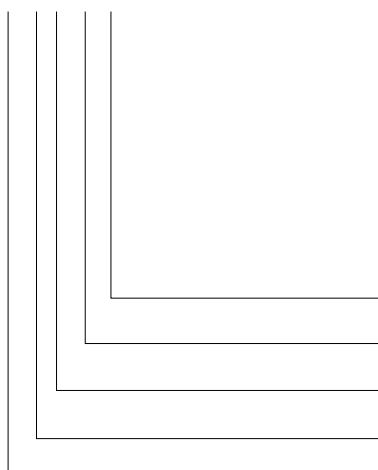

Length: l
100 mm
Diameter: d₁
16 mm
Type:
ISO
Execution:
blank
Punch:
with ejector pin

Order Code character
= (G)
Order No
= (8)
Order No
= (1)
Order No
= (0)
= 27

Material:

HSS
Hardness:
Shaft 64 ± 2 HRC
Head 52 ± 5 HRC

Execution:

Punch head hot upset-forged. Shoulder and shaft fine ground.
Special dimensions on request.

PUNCH, STEPPED, ROUND, WITH EJECTOR PIN, ISO 8020



2711.

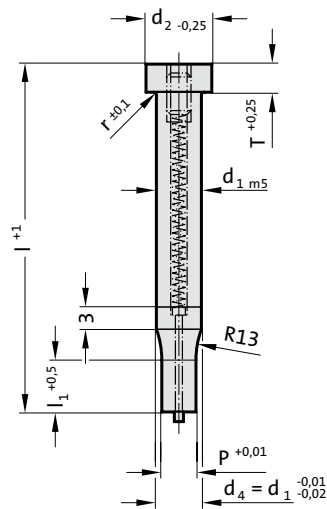

2711. Punch, stepped, round, with ejector pin, ISO 8020

d ₁ / Order No	d ₂	P	l ₁ / Order No	r	T	l / (Order Code character)	71 (D)	80 (E)	90 (F)	100 (G)	120 (J)
5 / (3)	8	2 - 4,9	13 (3) 19 (4)	0.3	5		●	●	●	●	●
6 / (4)	9	2,5 - 5,9	13 (3) 19 (4)	0.3	5		●	●	●	●	●
8 / (5)	11	4 - 7,9	19 (4) 25 (5)	0.3	5		●	●	●	●	●
10 / (6)	13	5 - 9,9	19 (4) 25 (5)	0.3	5		●	●	●	●	●
13 / (7)	16	6 - 12,9	19 (4) 25 (5)	0.4	5		●	●	●	●	●
16 / (8)	19	8 - 15,9	19 (4) 25 (5)	0.4	5		●	●	●	●	●
20 / (9)	23	10 - 19,9	19 (4) 25 (5)	0.4	5		●	●	●	●	●
25 / (10)	28	12 - 24,9	19 (4) 25 (5)	0.4	5		●	●	●	●	●
32 / (11)	35	16 - 31,9	25 (5) 30 (6)	0.4	5		●	●	●	●	●

Material:

HSS

Hardness:

Shaft 64 ± 2 HRC

Head 52 ± 5 HRC

Execution:

Punch head hot upset-forged. Shoulder, shaft and punch diameter fine ground.

Special dimensions on request.

Ordering Code (example):

2711.7G4.0720

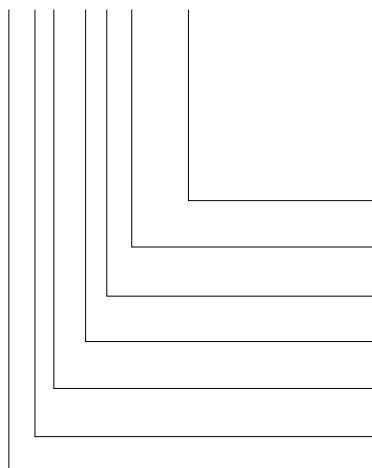

Shape: round

P = ∅ 7,2 mm

Punch cutting length: l₁
19 mm

Length: l

100 mm

Diameter: d₁

13 mm

Type:

ISO

Execution:

round

Punch:

with ejector pin

= 0720

Order No

= (4)

Order Code character

= (G)

Order No

= (7)

Order No

= (1)

Order No

= (1)

= 27

PUNCH, STEPPED, SQUARE, WITH EJECTOR PIN, ISO 8020

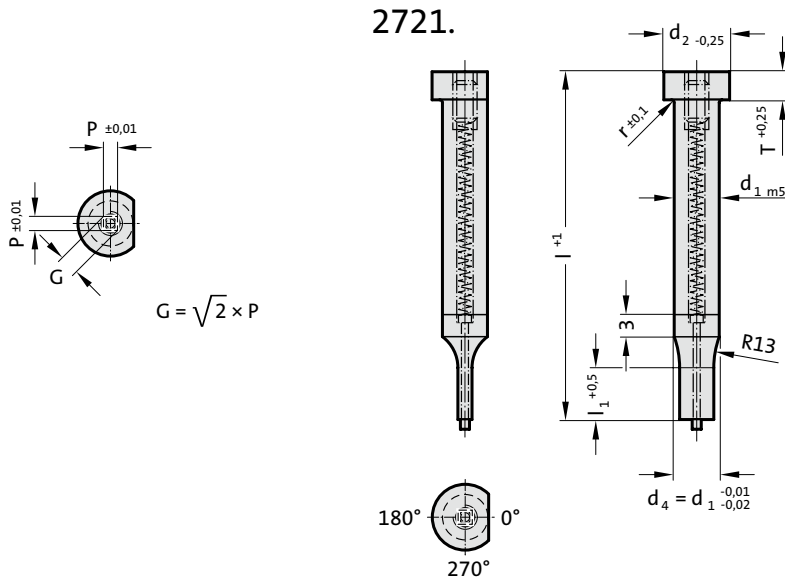

2721. Punch, stepped, square, with ejector pin, ISO 8020

d_1 / Order No	d_2	P_{min}	G_{max}	l_1 / Order No	r	T	l / (Order Code character)	71 (D)	80 (E)	90 (F)	100 (G)	120 (J)
5 / (3)	8	2	4.9	13 (3) 19 (4)	0.3	5		●	●	●	●	●
6 / (4)	9	2.5	5.9	13 (3) 19 (4)	0.3	5		●	●	●	●	●
8 / (5)	11	4	7.9	19 (4) 25 (5)	0.3	5		●	●	●	●	●
10 / (6)	13	4	9.9	19 (4) 25 (5)	0.3	5		●	●	●	●	●
13 / (7)	16	6	12.9	19 (4) 25 (5)	0.4	5		●	●	●	●	●
16 / (8)	19	8	15.9	19 (4) 25 (5)	0.4	5		●	●	●	●	●
20 / (9)	23	10	19.9	19 (4) 25 (5)	0.4	5		●	●	●	●	●
25 / (10)	28	12	24.9	19 (4) 25 (5)	0.4	5		●	●	●	●	●
32 / (11)	35	16	31.9	25 (5) 30 (6)	0.4	5		●	●	●	●	●

Ordering Code (example):

2721.9E5.1550.A

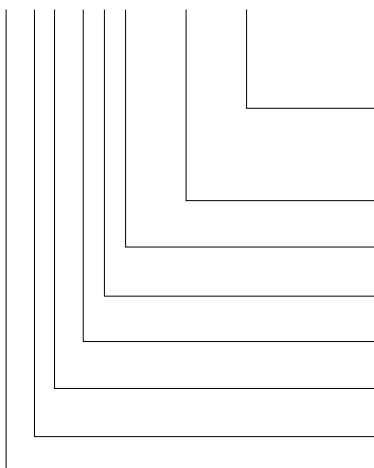

Angle:
0°

Shape: square, Length P

P = 15,5 mm

Punch cutting length: l_1
25 mm

Length: l
80 mm

Diameter: d_1
20 mm

Type:

ISO

Execution:

square

Punch:

with ejector pin

Order Code character
= (A)

= 1550

Order No

= (5)

Order Code character

= (E)

Order No

= (9)

Order No

= (1)

Order No

= (2)

= 27

Material:

HSS

Hardness:

Shaft 64 ± 2 HRC

Head 52 ± 5 HRC

Execution:

Punch head hot upset-forged. Shoulder, shaft and punch shape fine ground.

The anti-rotation surface parallel to P = 0° as standard.

Special dimensions on request.

Note:

With kerf ≤ 0.04 mm, FIBRO rounds off sharp edges if the punch and piercing die bush are ordered together. This reduces the fitting time and the risk of an edge break during operation.

PUNCH, STEPPED, RECTANGULAR, WITH EJECTOR PIN, ISO 8020



2731.

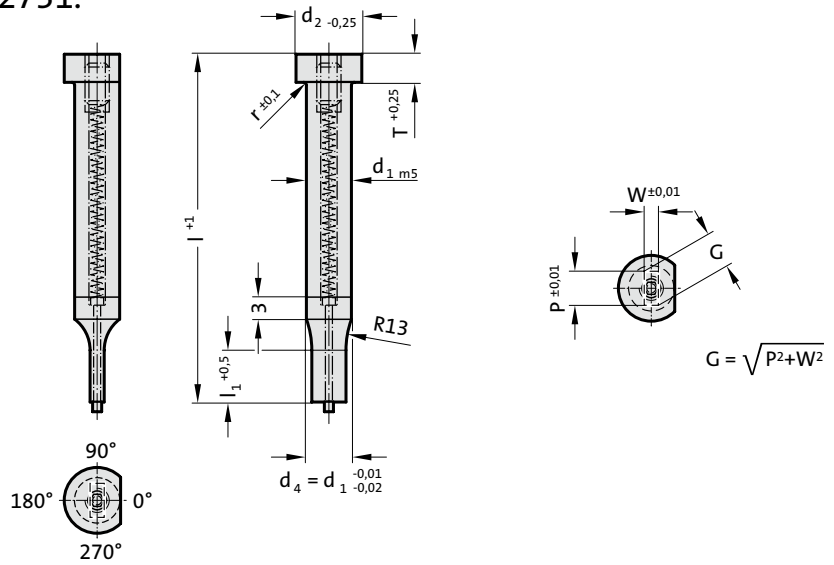

2731. Punch, stepped, rectangular, with ejector pin, ISO 8020

d ₁ / Order No	d ₂	W _{min}	G _{max}	l ₁ / Order No	r	T	l / (Order Code character)	71 (D)	80 (E)	90 (F)	100 (G)	120 (J)
5 / (3)	8	2	4.9	13 (3) 19 (4)	0.3	5		●	●	●	●	●
6 / (4)	9	2.5	5.9	13 (3) 19 (4)	0.3	5		●	●	●	●	●
8 / (5)	11	4	7.9	19 (4) 25 (5)	0.3	5		●	●	●	●	●
10 / (6)	13	4	9.9	19 (4) 205 (5)	0.3	5		●	●	●	●	●
13 / (7)	16	6	12.9	19 (4) 25 (5)	0.4	5		●	●	●	●	●
16 / (8)	19	8	15.9	19 (4) 25 (5)	0.4	5		●	●	●	●	●
20 / (9)	23	10	19.9	19 (4) 25 (5)	0.4	5		●	●	●	●	●
25 / (10)	28	12	24.9	19 (4) 25 (5)	0.4	5		●	●	●	●	●
32 / (11)	35	16	31.9	25 (5) 30 (6)	0.4	5		●	●	●	●	●

Material:

HSS

Hardness:

Shaft 64 ± 2 HRC

Head 52 ± 5 HRC

Execution:

Punch head hot upset-forged. Shoulder, shaft and punch shape fine ground.

The anti-rotation surface parallel to P = 0° as standard.

Special dimensions on request.

Note:

With kerf ≤ 0.04 mm, FIBRO rounds off sharp edges if the punch and piercing die bush are ordered together. This reduces the fitting time and the risk of an edge break during operation.

Ordering Code (example):

2731.9F4.1550.1150.A

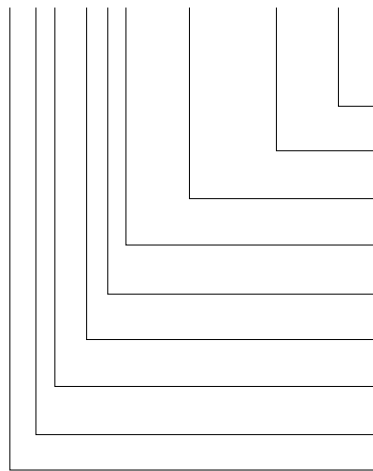

Angle:

0°

Shape: rectangular, Width W

W = 11,5 mm

Shape: rectangular, Length P

P = 15,5 mm

Punch cutting length: l₁

19 mm

Length: l

90 mm

Diameter: d₁

20 mm

Type:

ISO

Execution:

rectangular

Punch:

with ejector pin

Order Code character
= (A)

= 1150

= 1550

Order No

= (4)

Order Code character

= (F)

Order No

= (9)

Order No

= (1)

Order No

= (3)

= 27

PUNCH, STEPPED, SLOT, WITH EJECTOR PIN, ISO 8020

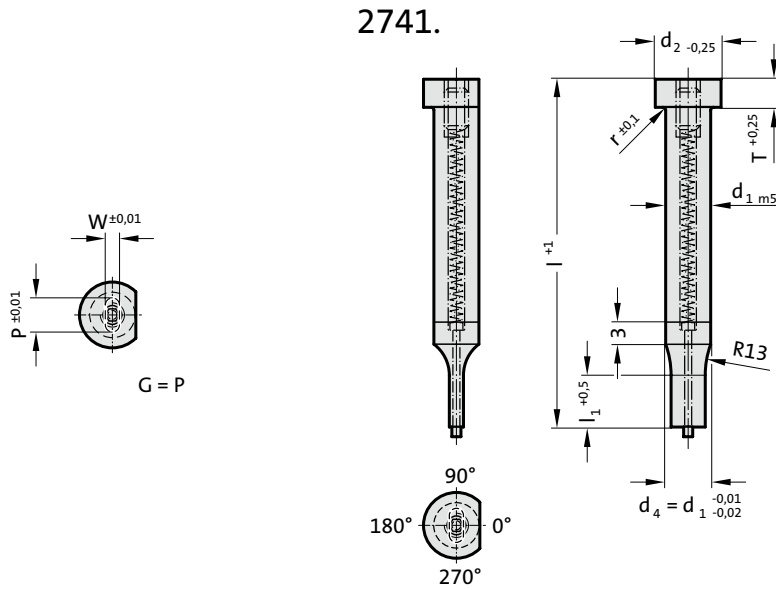

2741. Punch, stepped, slot, with ejector pin, ISO 8020

d ₁ / Order No	d ₂	W _{min}	G _{max}	l ₁ / Order No	r	T	l / (Order Code character)	71 (D)	80 (E)	90 (F)	100 (G)	120 (J)
5 / (3)	8	2	4.9	13 (3) 19 (4)	0.3	5		●	●	●	●	●
6 / (4)	9	2.5	5.9	13 (3) 19 (4)	0.3	5		●	●	●	●	●
8 / (5)	11	4	7.9	19 (4) 25 (5)	0.3	5		●	●	●	●	●
10 / (6)	13	4	9.9	19 (4) 25 (5)	0.3	5		●	●	●	●	●
13 / (7)	16	6	12.9	19 (4) 25 (5)	0.4	5		●	●	●	●	●
16 / (8)	19	8	15.9	19 (4) 25 (5)	0.4	5		●	●	●	●	●
20 / (9)	23	10	19.9	19 (4) 25 (5)	0.4	5		●	●	●	●	●
25 / (10)	28	12	24.9	19 (4) 25 (5)	0.4	5		●	●	●	●	●
32 / (11)	35	16	31.9	25 (5) 30 (6)	0.4	5		●	●	●	●	●

Ordering Code (example):

2741.9E5.1650.1220.B

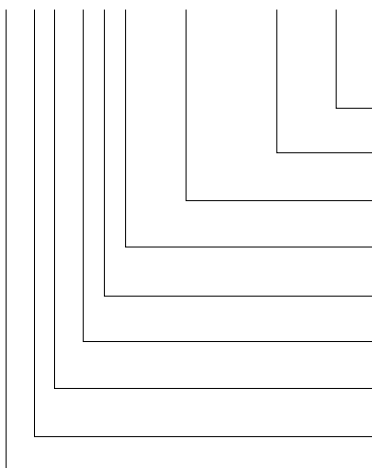

Angle:
90°
Shape: slot, Width W
W = 12,2 mm
Shape: slot, Length P
P = 16,5 mm
Punch cutting length: l₁
25 mm
Length: l
80 mm
Diameter: d₁
20 mm
Type:
ISO
Execution:
slot
Punch:
with ejector pin

Order Code character
= (B)
= 1220
= 1650
Order No
= (5)
Order Code character
= (E)
Order No
= (9)
Order No
= (1)
Order No
= (4)
= 27

Material:

HSS
Hardness:
Shaft 64 ± 2 HRC
Head 52 ± 5 HRC

Execution:

Punch head hot upset-forged. Shoulder, shaft and punch shape fine ground.
The anti-rotation surface parallel to P = 0° as standard.
Special dimensions on request.

PUNCH, STEPPED, RECTANGLE WITH RADIUSSED CORNERS, WITH EJECTOR PIN, ISO 8020



2751.

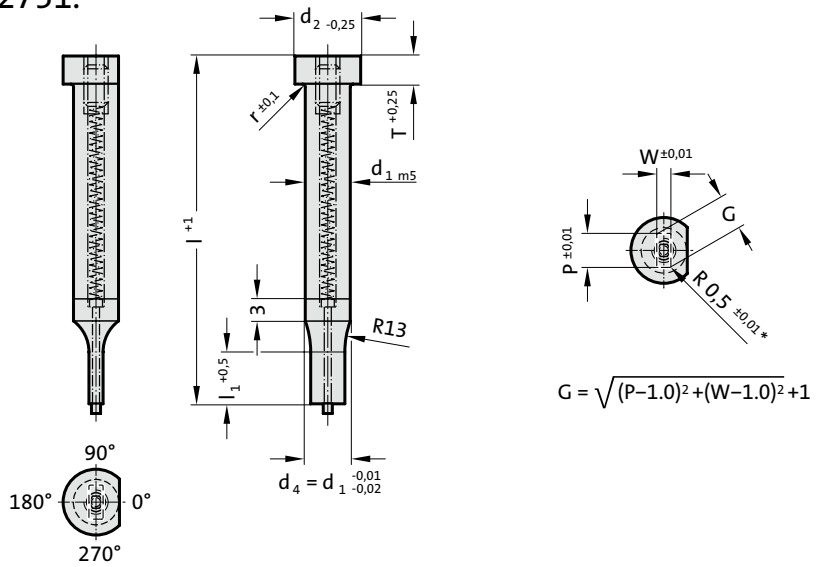

2751. Punch, stepped, rectangle with radiused corners, with ejector pin, ISO 8020

d ₁ / Order No	d ₂	W _{min}	G _{max}	l ₁ / Order No	r	T	l / (Order Code character)	71 (D)	80 (E)	90 (F)	100 (G)	120 (J)
5 / (3)	8	2	4.9	13 (3) 19 (4)	0.3	5		●	●	●	●	●
6 / (4)	9	2.5	5.9	13 (3) 19 (4)	0.3	5		●	●	●	●	●
8 / (5)	11	4	7.9	19 (4) 25 (5)	0.3	5		●	●	●	●	●
10 / (6)	13	4	9.9	19 (4) 25 (5)	0.3	5		●	●	●	●	●
13 / (7)	16	6	12.9	19 (4) 25 (5)	0.4	5		●	●	●	●	●
16 / (8)	19	8	15.9	19 (4) 25 (5)	0.4	5		●	●	●	●	●
20 / (9)	23	10	19.9	19 (4) 25 (5)	0.4	5		●	●	●	●	●
25 / (10)	28	12	24.9	19 (4) 25 (5)	0.4	5		●	●	●	●	●
32 / (11)	35	16	31.9	25 (5) 30 (6)	0.4	5		●	●	●	●	●

Material:

HSS

Hardness:

Shaft 64 ± 2 HRC

Head 52 ± 5 HRC

Execution:

Punch head hot upset-forged. Shoulder, shaft and punch shape fine ground.

The anti-rotation surface parallel to P = 0° as standard.

Special dimensions on request.

* For other radius options, see standardised special shapes.

Ordering Code (example):

2751.9F4.1550.1150.A

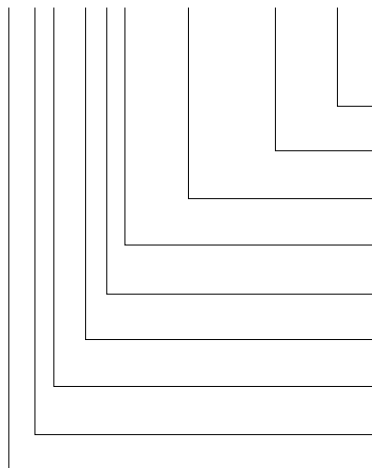

Angle:

0°

Shape: rectangle with radiused corners, Width W

W = 11,5 mm

Shape: rectangle with radiused corners, Length P

P = 15,5 mm

Punch cutting length: l₁

19 mm

Length: l

90 mm

Diameter: d₁

20 mm

Type:

ISO

Execution:

rectangle with radiused corners

Punch:

with ejector pin

Order Code character
= (A)

Order Code character
= 1150

Order Code character
= 1550

Order No

= (4)

Order Code character

= (F)

Order No

= (9)

Order No

= (1)

Order No

= (5)

= 27

PILOT PIN WITH TAPERED TIP, ISO 8020

2261.

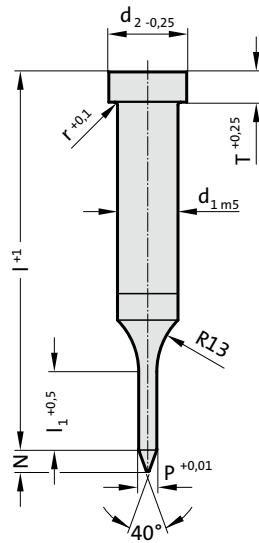

2261. Pilot pin with tapered tip, ISO 8020

d ₁ / Order No	d ₂	T	P	l ₁ / Order No	N	l / (Order Code character)	63 (C)	71 (D)	80 (E)	90 (F)	100 (G)	110 (H)	125 (K)	140 (L)
5 / (3)	8	5	1 - 4,9	13 (3)	4		●	●						
6 / (4)	9	5	1,6 - 5,9	13 (3)	5		●	●	●					
8 / (5)	11	5	2,5 - 7,9	13 (3)	6		●	●	●	●				
10 / (6)	13	5	4 - 9,9	13 (3) 19 (4)	8		●	●	●	●	●			
13 / (7)	16	5	5 - 12,9	13 (3) 19 (4)	10		●	●	●	●	●	●		
16 / (8)	19	5	8 - 15,9	13 (3) 19 (4) 25 (5)	15		●	●	●	●	●	●	●	
20 / (9)	23	5	12 - 19,9	13 (3) 19 (4) 25 (5)	20		●	●	●	●	●	●	●	●
25 / (10)	28	5	16,5 - 24,9	13 (3) 19 (4) 25 (5)	25		●	●	●	●	●	●	●	●
32 / (11)	35	5	20 - 31,9	19 (4) 25 (5)	30		●	●	●	●	●	●	●	●

Ordering Code (example):

2261.6G3.0710

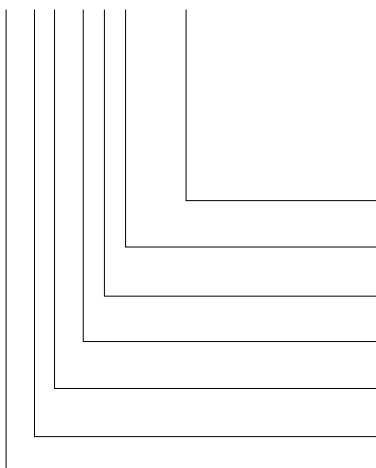

Shape: round

P = Ø 7,1 mm

Punch cutting length: l₁

13 mm

Length: l

100 mm

Diameter: d₁

10 mm

Type:

ISO

Execution:

Pilot pin with tapered tip

Punch:

without ejector pin

= 0710

Order No

= (3)

Order Code character

= (G)

Order No

= (6)

Order No

= (1)

Order No

= (6)

= 22

Material:

HSS

Hardness:

Shaft 64 ± 2 HRC

Head 52 ± 5 HRC

Execution:

Head hot upset-forged. Shoulder, shaft and pilot fine ground.

Special dimensions on request.

PILOT PIN WITH PARABOLIC TIP, ISO 8020



2271.

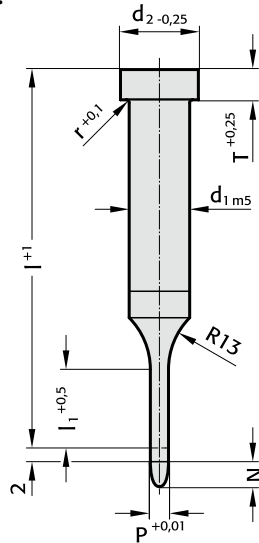

2271. Pilot pin with parabolic tip, ISO 8020

d ₁ / Order No	d ₂	T	P	l ₁ / Order No	l / (Order Code character)	50 (A)	56 (B)	63 (C)	71 (D)	80 (E)	90 (F)	100 (G)
5 / (3)	8	5	1 - 4,9	10 (2) 13 (3)		●	●	●	●			
6 / (4)	9	5	1,6 - 5,9	10 (2) 13 (3)		●	●	●	●	●		
8 / (5)	11	5	2,5 - 7,9	10 (2) 13 (3)		●	●	●	●	●		
10 / (6)	13	5	4 - 9,9	10 (2) 13 (3) 19 (4)		●	●	●	●	●	●	●
13 / (7)	16	5	5 - 12,9	10 (2) 13 (3) 19 (4)		●	●	●	●	●	●	●
16 / (8)	19	5	8 - 15,9	13 (3) 19 (4)		●	●	●	●	●	●	●
20 / (9)	23	5	12 - 19,9	13 (3) 19 (4)			●	●	●	●	●	●
25 / (10)	28	5	16,5 - 24,9	13 (3) 19 (4)			●	●	●	●	●	●
32 / (11)	35	5	20 - 31,9	19 (4)					●	●	●	●

Material:

HSS

Hardness:

Shaft 64 ± 2 HRC

Head 52 ± 5 HRC

Execution:

Head hot upset-forged. Shoulder, shaft and pilot fine ground.

Special dimensions on request.

Note:

The 2 mm length provides full guidance before the blanking punch contacts the sheet metal.

Length of parabolic tip N:

= 8 mm where P ≤ 10 mm

=12 mm where P 10,1 mm - 15 mm

=15 mm where P > 15 mm

Ordering Code (example):

2271.9F4.1870

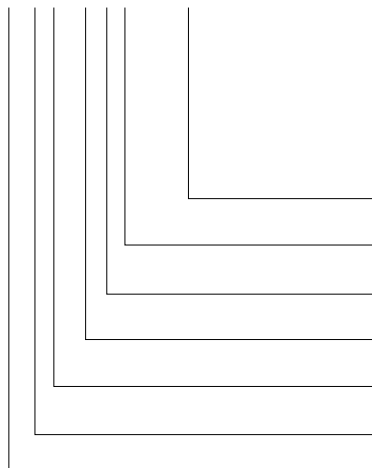

Shape: round

P = ∅ 18,7 mm

Punch cutting length: l₁
19 mm

Length: l

90 mm

Diameter: d₁

20 mm

Type:

ISO

Execution:

Pilot pin with parabolic tip

Punch:

without ejector pin

= 1870

Order No

= (4)

Order Code character

= (F)

Order No

= (9)

Order No

= (1)

Order No

= (7)

= 22

PILOT UNIT TO MERCEDES-BENZ STANDARD

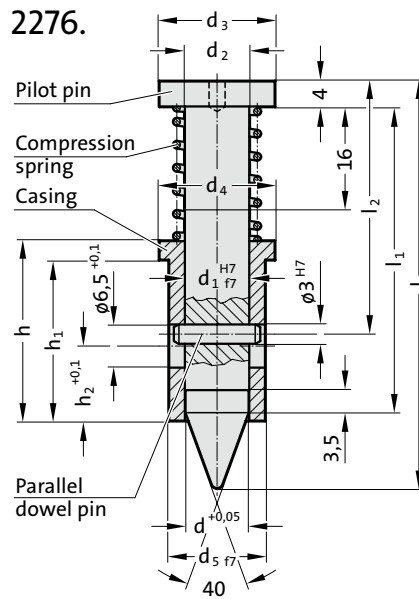

2276. Pilot unit to Mercedes-Benz Standard

Order No	d	d ₁	d ₂	d ₃	d ₄	d ₅	h	h ₁	h ₂	l ₁	l ₂	l	Spring force preloaded [daN]	Spring force pressed [daN]
2276.1.A.0980	9.8	10	10	18	18	15	28	25	12	47.5	39.3	63.2	4.9	6.2
2276.2.B.1580	15.8	16	16	24	30	26	28	25	12	54.5	46.3	72.5	4.8	5.6

Ordering Code (example):

2276.1.A.0980

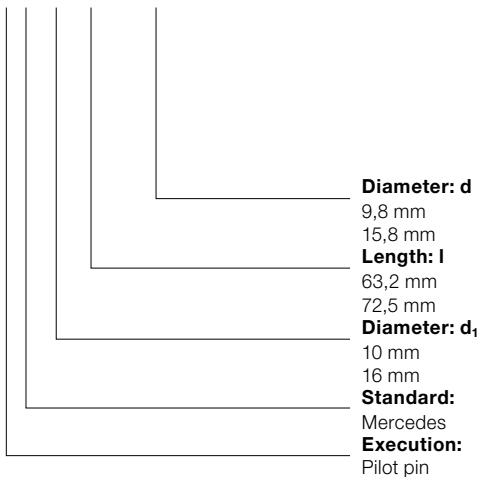

- = 0980
- = 1580
- Order Code character**
- = (A)
- = (B)
- Order No**
- = (1)
- = (2)
- Order No**
- = (6)
- Order No**
- = (7)
- = 22

Description:

The pilot unit provides exact positioning of sheet metal parts.

There are 2 sizes.

The pilot unit 10 (2276.1.) can be used for a hole diameter of 5 to 10 mm and is available as a finished item, 9.8 mm diameter.

The pilot unit 16 (2276.2.) is used for diameter > 10 - 16 mm and is available as a finished item, 15.8 mm diameter.

Smaller diameters have to be ground by the tool making department.

Material:

Sleeve: 1.3505
Hardness 58 ± 2 HRC
Pilot pin: 1.2550
Hardness 50 ± 2 HRC

Execution:

The pilot unit consists of:
Pilot pin, sleeve, compression spring, dowel pin.

MATRIXES



CUTTING BUSHINGS - ORDER EXAMPLE

Note: See table for standard dimensions
Special dimensions to order

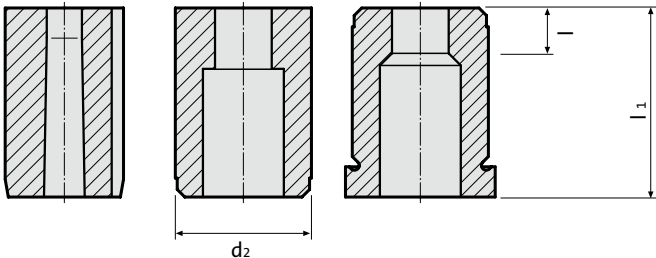

2 6 4 6 . 1 0 F 6 . 1 3 5 0 . 0 6 5 0 . A 2

Matrixes:
26 = matrixes

Execution:	Order No
○ blank (pilot hole bore)	= 0
○ round	= 1
□ square	= 2
▭ rectangular	= 3
○ slot	= 4
○ rectangle with radiused corners	= 5
special shapes	= 9

Type:	Order No
automotive standard	= 5
without shoulder ISO 8977	= 6
with shoulder ISO 8977	= 7

Shape cutting length: l	Order No
2	= 1
3	= 2
4	= 3
5	= 4
6	= 5
8	= 6
10	= 7
12	= 8
special	= X

Format: Slot length P = 13.5 mm

Format: Slot width W = 6.5 mm

Length: l ₁	Order Code character
13	= A
16	= B
20	= C
22	= D
25	= E
28	= F
30	= G
32	= H
35	= J
40	= K
special	= X

Diameter: d ₂	Order No
5	= 1
6	= 2
8	= 3
10	= 4
13	= 5
16	= 6
20	= 7
22	= 8
25	= 9
32	= 10
38	= 11
40	= 12
45	= 13
50	= 14
56	= 15
63	= 16
71	= 17
76	= 18
85	= 19
90	= 20
100	= 21

Angle:	Order Code character
0°	= A
90°	= B
180°	= C
270°	= D
special	= X

Anti-rotation element:	Order No
Pin ø3	= 1
Pin ø4	= 2
Pin ø6	= 3
polished Surface (continuous)	= 4
polished Surface top, 14 mm	= 5
polished Surface bottom, 14 mm	= 6
special	= X

Ordering Code (example):

2 6 4 6 . 1 0 F 6 . 1 3 5 0 . 0 6 5 0 . A 2

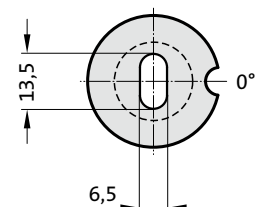
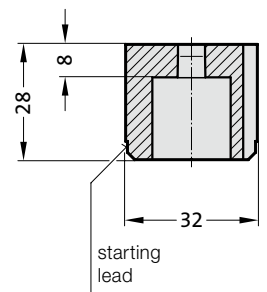
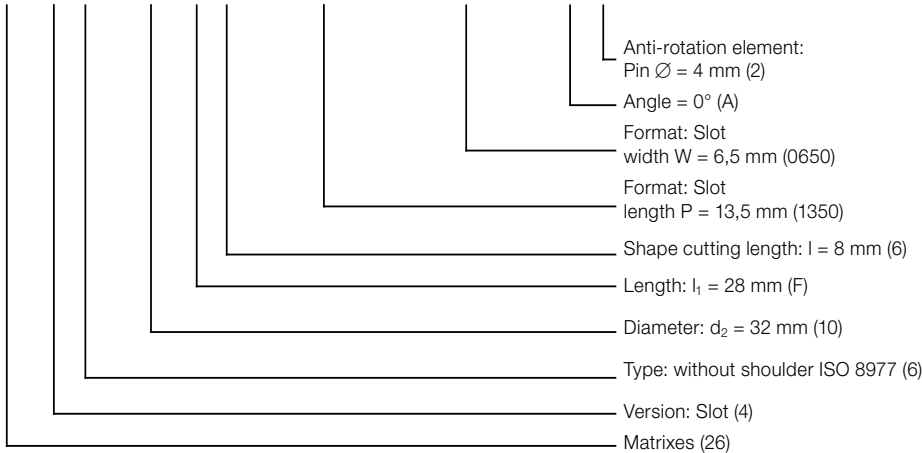

MATRIX WITHOUT SHOULDER, BLANK, ISO 8977

2606.

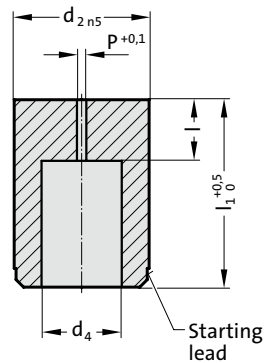

2606. Matrix without shoulder, blank, ISO 8977

d ₂ / Order No	d ₄	P	l / Order No	l ₁ / (Order Code character)	16 (B)	20 (C)	22 (D)	25 (E)	28 (F)	30 (G)	32 (H)	35 (J)	40 (K)
5 / (1)	2.8	0.8	2 (1)		●	●	●	●	●	●	●	●	
6 / (2)	3.5	1	3 (2)		●	●	●	●	●	●	●	●	
8 / (3)	4	1	4 (3)		●	●	●	●	●	●	●	●	●
10 / (4)	5.8	1	4 (3) 8 (6)		●	●	●	●	●	●	●	●	●
13 / (5)	8	1.2	5 (4) 8 (6)			●	●	●	●	●	●	●	●
16 / (6)	9.5	1.2	5 (4) 8 (6)			●	●	●	●	●	●	●	●
20 / (7)	12	1.5	8 (6) 12 (8)			●	●	●	●	●	●	●	●
22 / (8)	15	1.5	8 (6) 12 (8)			●	●	●	●	●	●	●	●
25 / (9)	17.3	1.5	8 (6) 12 (8)			●	●	●	●	●	●	●	●
32 / (10)	20.7	1.5	8 (6) 12 (8)			●	●	●	●	●	●	●	●
38 / (11)	27.7	1.5	8 (6) 12 (8)					●	●	●	●	●	●
40 / (12)	27.7	1.5	8 (6) 12 (8)					●	●	●	●	●	●
50 / (14)	37	1.5	8 (6) 12 (8)					●	●	●	●	●	●

Ordering Code (example):

2606.10F8

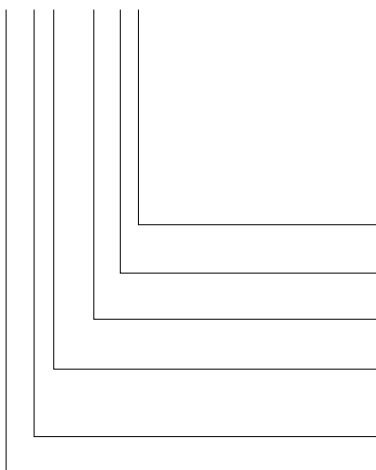

Shape cutting length: l
12 mm
Length: l₁
28 mm
Diameter: d₂
32 mm
Type:
without shoulder
ISO 8977
Execution:
blank (pilot hole bore)
Matrix

Order No
= (8)
Order Code character
= (F)
Order No
= (10)
Order No
= (6)
Order No
= (0)
Order No
= 26

Material:

HSS
Hardness 62 ± 2 HRC

Execution:

Diameter d₂, starting lead and face surfaces ground.
Diameter P is a bored pilot hole for wire EDM.
Special dimensions on request.

MATRIX WITHOUT SHOULDER, ROUND, ISO 8977



2616.

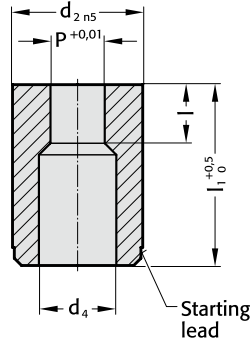

2616. Matrix without shoulder, round, ISO 8977

d ₂ / Order No	d ₄	P	l / Order No	l ₁ / (Order Code character)	16 (B)	20 (C)	22 (D)	25 (E)	28 (F)	30 (G)	32 (H)	35 (J)	40 (K)
5 / (1)	2.8	1 - 2,4	2 (1)		●	●	●	●	●	●	●	●	
6 / (2)	3.5	1,6 - 3	3 (2)		●	●	●	●	●	●	●	●	
8 / (3)	4	2 - 3,5	4 (3)		●	●	●	●	●	●	●	●	
10 / (4)	5.8	2,5 - 5	4 (3) 8 (6)		●	●	●	●	●	●	●	●	
13 / (5)	8	4 - 7	5 (4) 8 (6)			●	●	●	●	●	●	●	
16 / (6)	9.5	6 - 9	5 (4) 8 (6)			●	●	●	●	●	●	●	
20 / (7)	12	8 - 11	8 (6) 12 (8)			●	●	●	●	●	●	●	
22 / (8)	15	9 - 14	8 (6) 12 (8)			●	●	●	●	●	●	●	
25 / (9)	17.3	10,7 - 16	8 (6) 12 (8)			●	●	●	●	●	●	●	
32 / (10)	20.7	15 - 20	8 (6) 12 (8)			●	●	●	●	●	●	●	
38 / (11)	27.7	19 - 27	8 (6) 12 (8)					●	●	●	●	●	
40 / (12)	27.7	19 - 27	8 (6) 12 (8)					●	●	●	●	●	
50 / (14)	37	26 - 36	8 (6) 12 (8)					●	●	●	●	●	●

Material:

HSS
Hardness 62 ± 2 HRC

Execution:

Diameter d₂, starting lead and face surfaces ground.
Special dimensions on request.

Ordering Code (example): without anti-rotation element

2616.10F8.1510

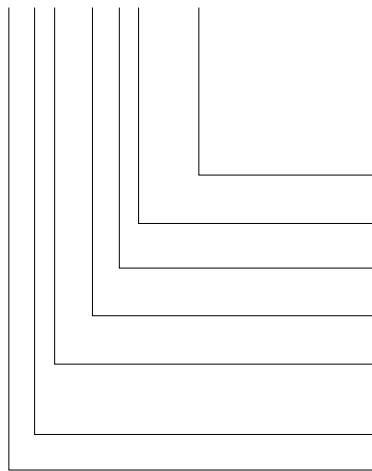

Shape: round
P = 015,1 mm
Shape cutting length: l
12 mm
Length: l₁
28 mm
Diameter: d₂
32 mm
Type:
without shoulder
ISO 8977
Execution:
round
Matrix

= 1510
Order No
= (8)
Order Code character
= (F)
Order No
= (10)
Order No
= (6)
Order No
= (1)
= 26

MATRIXES WITHOUT SHOULDER, CYLINDRICAL, ISO 8977, ANTI-ROTATION ELEMENTS

Anti-rotation element 1 (1)

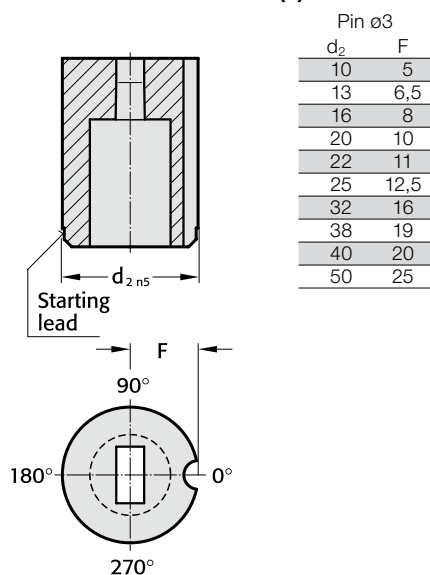

Anti-rotation element 2 (2)

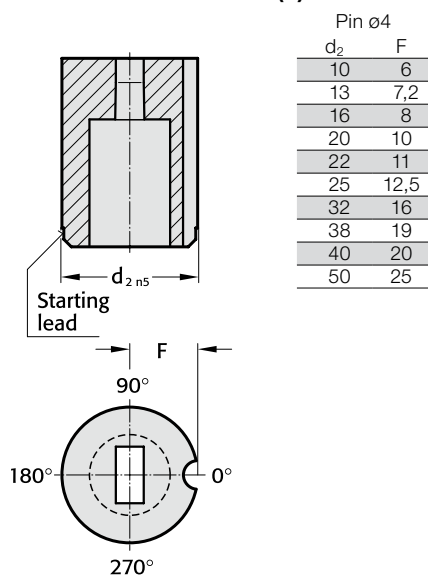

Anti-rotation element 3 (3)

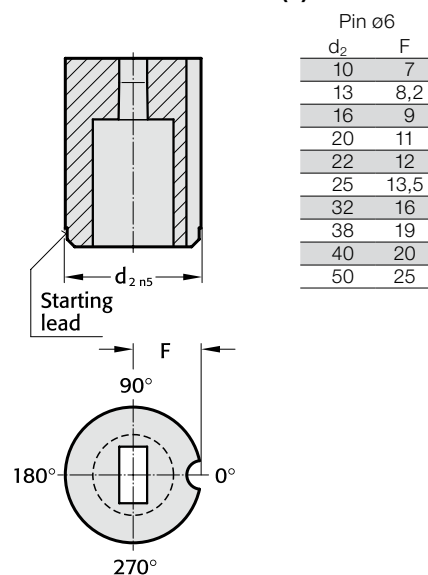

Anti-rotation element 4 (4)

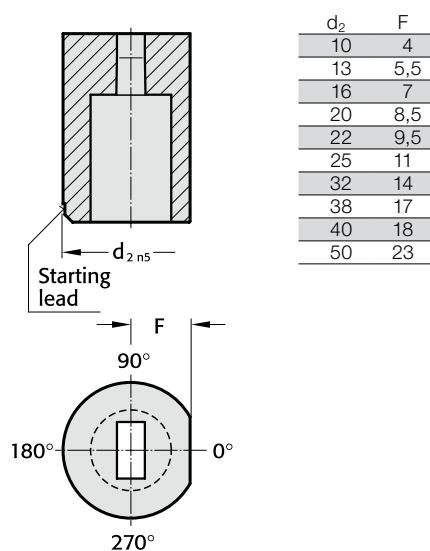

Anti-rotation element 5 (5)

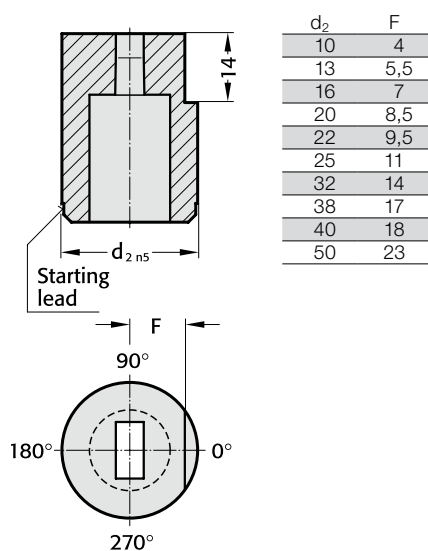

Anti-rotation element 6 (6)

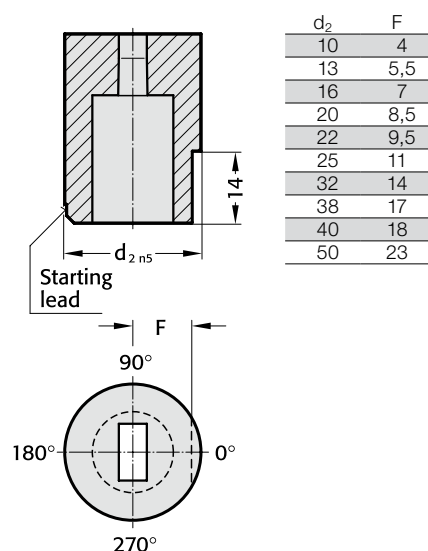

Ordering Code (example): with anti-rotation element from $d_2 \geq 10$ mm

2616.10F8.1510.A4

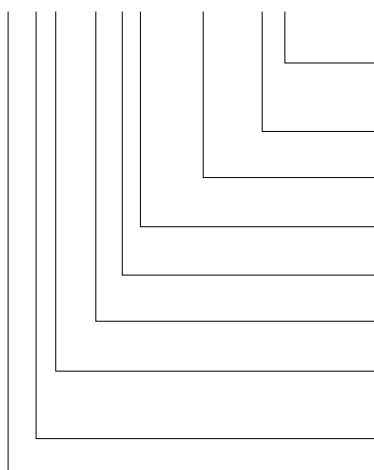

Anti-rotation element:

Polished surface
(continuous)

Angle:
 0°

Shape: round
 $P = \varnothing 15,1$ mm

Shape cutting length: l
12 mm

Length: l_1
28 mm

Diameter: d_2
32 mm

Type:
without shoulder
ISO 8977

Execution:
round

Matrix

Order No
= (4)

Order Code character
= (A)

= 1510

Order No
= (8)

Order Code character
= (F)

Order No
= (10)

Order No

= (6)

Order No

= (1)

= 26

MATRIX WITHOUT SHOULDER, SQUARE, ISO 8977



2626.

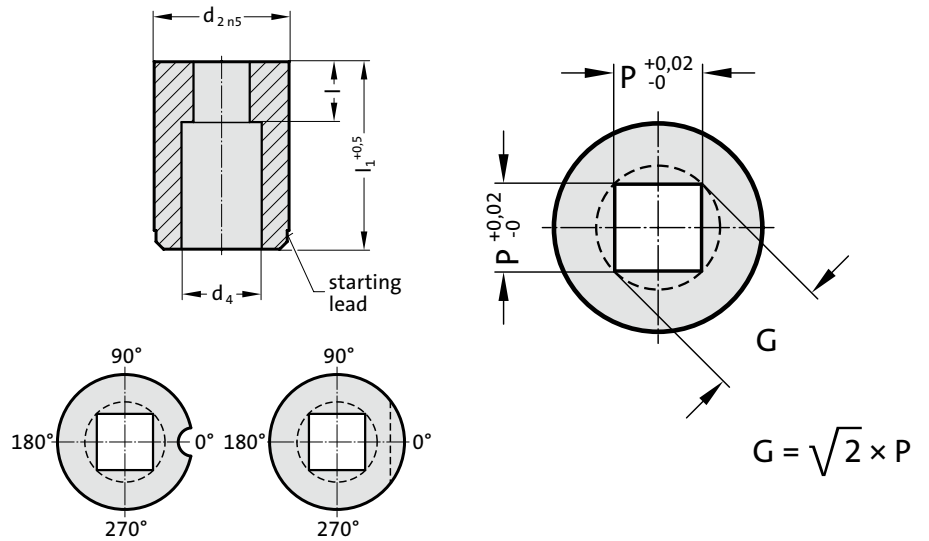

2626. Matrix without shoulder, square, ISO 8977

d ₂ / Order No	d ₄	P _{min}	G _{max}	l / Order No	l ₁ / (Order Code character)	16 (B)	20 (C)	22 (D)	25 (E)	28 (F)	30 (G)	32 (H)	35 (J)	40 (K)
10 / (4)	5.8	1.2	5	4 (3) 8 (6)		●	●	●	●	●	●	●	●	●
13 / (5)	8	2	7	5 (4) 8 (6)			●	●	●	●	●	●	●	●
16 / (6)	9.5	2.4	9	5 (4) 8 (6)			●	●	●	●	●	●	●	●
20 / (7)	12	3.2	11	8 (6) 12 (8)			●	●	●	●	●	●	●	●
22 / (8)	15	4	14	8 (6) 12 (8)			●	●	●	●	●	●	●	●
25 / (9)	17.3	4.8	16	8 (6) 12 (8)			●	●	●	●	●	●	●	●
32 / (10)	20.7	5.5	20	8 (6) 12 (8)			●	●	●	●	●	●	●	●
38 / (11)	27.7	6.4	27	8 (6) 12 (8)					●	●	●	●	●	●
40 / (12)	27.7	6.4	27	8 (6) 12 (8)					●	●	●	●	●	●
50 / (14)	37	9	36	8 (6) 12 (8)					●	●	●	●	●	●

Material:

HSS
Hardness 62 ± 2 HRC

Execution:

Diameter d₂, starting lead and face surfaces ground.
Special dimensions on request.

Note:

With kerf ≤ 0.04 mm, FIBRO rounds off sharp edges if the punch and piercing die bush are ordered together. This reduces the fitting time and the risk of an edge break during operation.

Ordering Code (example): with anti-rotation element

2626.10F8.1350.A3

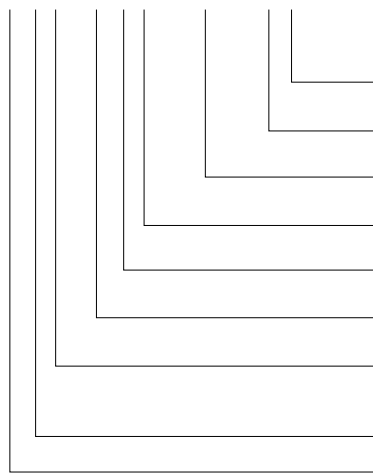

Anti-rotation element:

Pin Ø 6 mm

Angle:

0°

Shape: square, Length P

P = 13,5 mm

Shape cutting length: l

12 mm

Length: l₁

28 mm

Diameter: d₂

32 mm

Type:

without shoulder
ISO 8977

Execution:

square

Matrix

Order No

= (3)

Order Code character

= (A)

= 1350

Order No

= (8)

Order Code character

= (F)

Order No

= (10)

Order No

= (6)

Order No

= (2)

= 26

MATRIXES WITHOUT SHOULDER, CYLINDRICAL, ISO 8977, ANTI-ROTATION ELEMENTS

Anti-rotation element 1 (1)

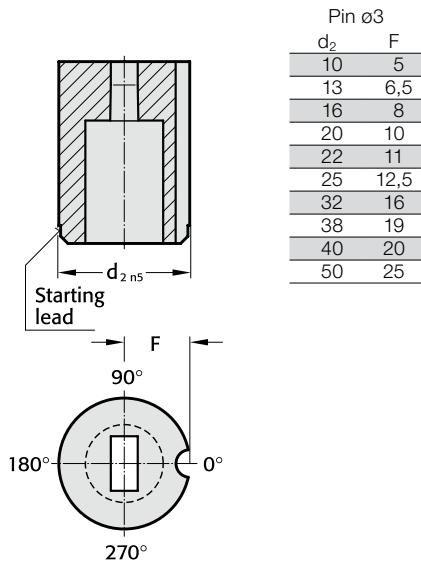

Anti-rotation element 2 (2)

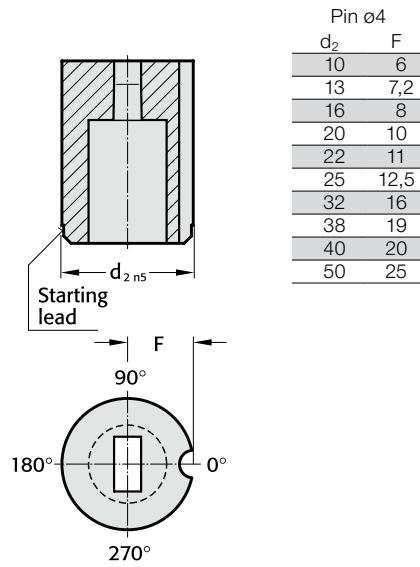

Anti-rotation element 3 (3)

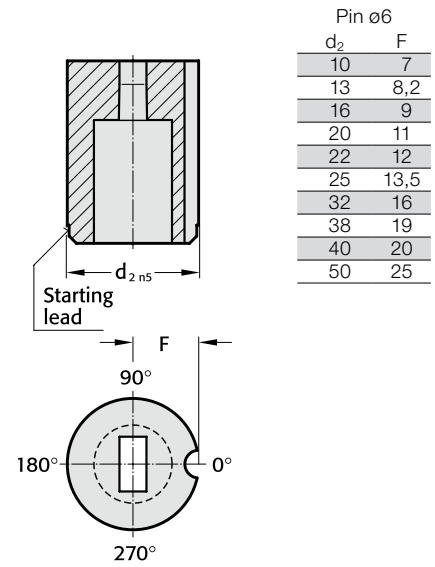

Anti-rotation element 4 (4)

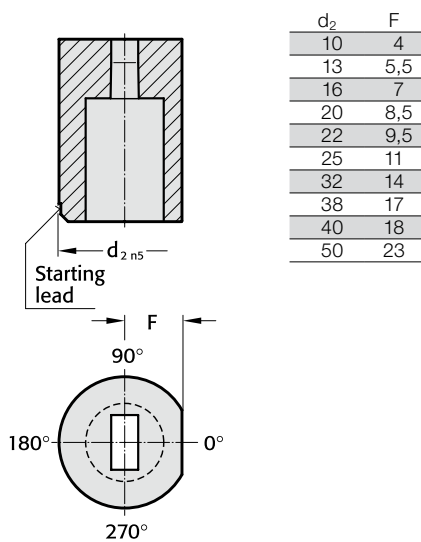

Anti-rotation element 5 (5)

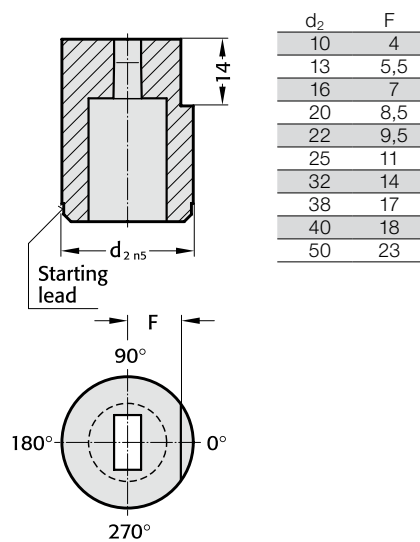

Anti-rotation element 6 (6)

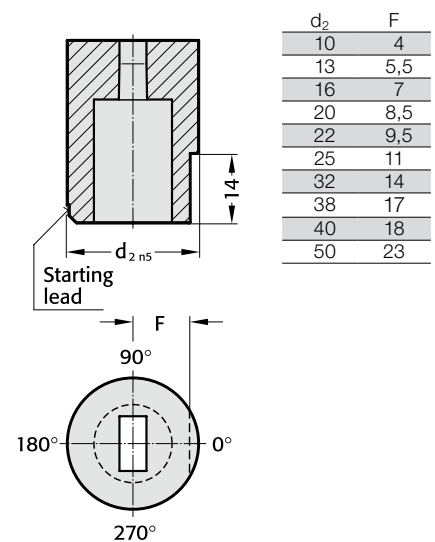

MATRIX WITHOUT SHOULDER, RECTANGULAR, ISO 8977



2636.

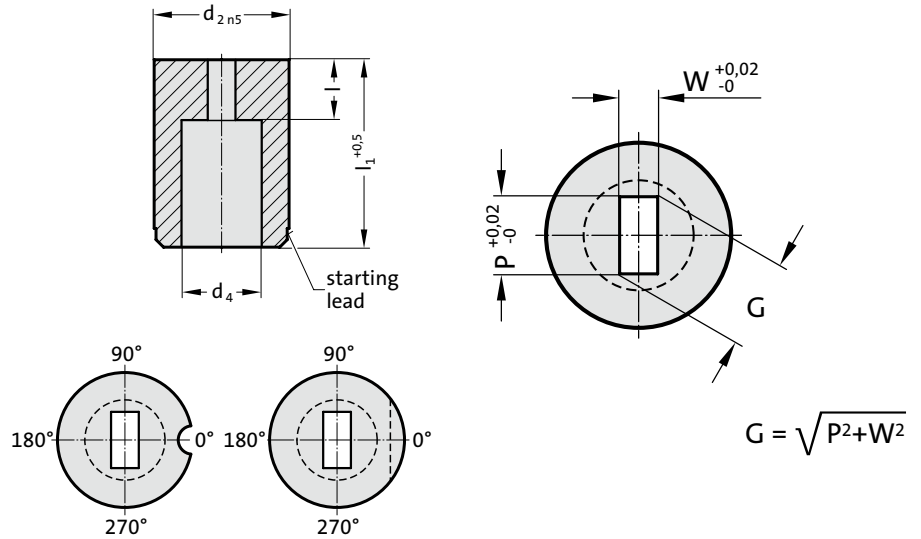

2636. Matrix without shoulder, rectangular, ISO 8977

d ₂ / Order No	d ₄	W _{min}	G _{max}	l / Order No	l ₁ / (Order Code character)	16 (B)	20 (C)	22 (D)	25 (E)	28 (F)	30 (G)	32 (H)	35 (J)	40 (K)
10 / (4)	5.8	1.2	5	4 (3) 8 (6)		●	●	●	●	●	●	●	●	●
13 / (5)	8	2	7	5 (4) 8 (6)			●	●	●	●	●	●	●	●
16 / (6)	9.5	2.4	9	5 (4) 8 (6)			●	●	●	●	●	●	●	●
20 / (7)	12	3.2	11	8 (6) 12 (8)			●	●	●	●	●	●	●	●
22 / (8)	15	4	14	8 (6) 12 (8)			●	●	●	●	●	●	●	●
25 / (9)	17.3	4.8	16	8 (6) 12 (8)			●	●	●	●	●	●	●	●
32 / (10)	20.7	5.5	20	8 (6) 12 (8)			●	●	●	●	●	●	●	●
38 / (11)	27.7	6.4	27	8 (6) 12 (8)					●	●	●	●	●	●
40 / (12)	27.7	6.4	27	8 (6) 12 (8)					●	●	●	●	●	●
50 / (14)	37	9	36	8 (6) 12 (8)					●	●	●	●	●	●

Material:

HSS
Hardness 62 ± 2 HRC

Execution:

Diameter d₂, starting lead and face surfaces ground.
Special dimensions on request.

Note:

With kerf ≤ 0.04 mm, FIBRO rounds off sharp edges if the punch and piercing die bush are ordered together. This reduces the fitting time and the risk of an edge break during operation.

Ordering Code (example): with anti-rotation element

2636.10F8.1350.0650.B4

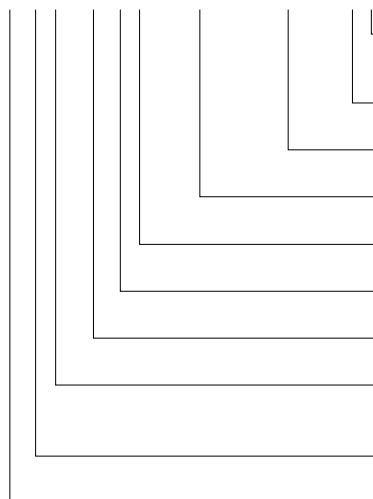

Anti-rotation element:

Polished surface (continuous)

Angle:

90°

Shape: rectangular, Width W

W = 6,5 mm

Shape: rectangular, Length P

P = 13,5 mm

Shape cutting length: l

12 mm

Length: l₁

28 mm

Diameter: d₂

32 mm

Type:

without shoulder
ISO 8977

Execution:

rectangular

Matrix

Order No

= (4)

Order Code character

= (B)

= 0650

= 1350

Order No

= (8)

Order Code character

= (F)

Order No

= (10)

Order No

= (6)

Order No

= (3)

= 26

MATRIXES WITHOUT SHOULDER, CYLINDRICAL, ISO 8977, ANTI-ROTATION ELEMENTS

Anti-rotation element 1 (1)

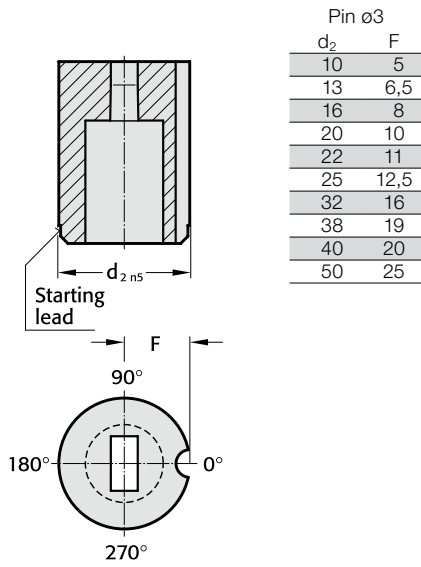

Anti-rotation element 2 (2)

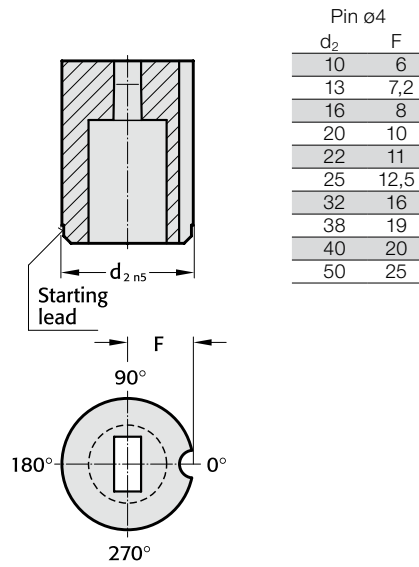

Anti-rotation element 3 (3)

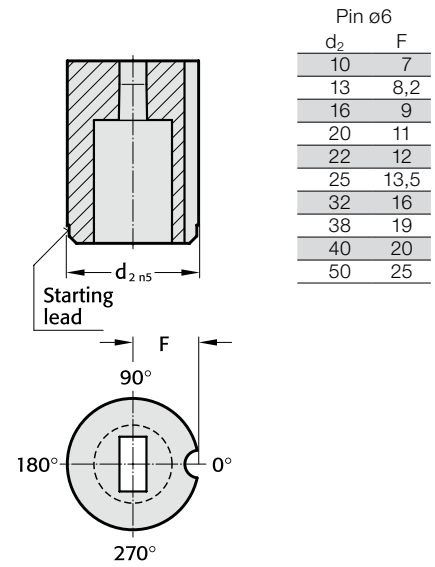

Anti-rotation element 4 (4)

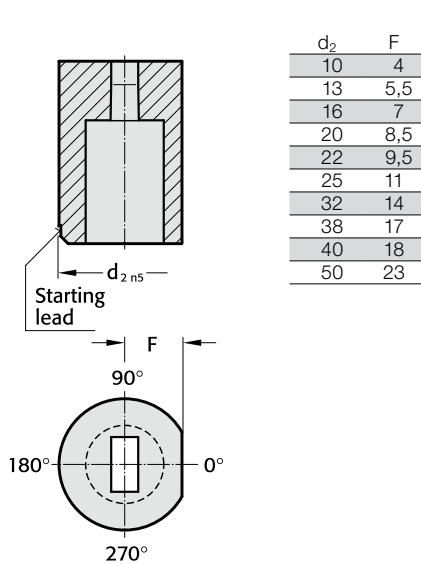

Anti-rotation element 5 (5)

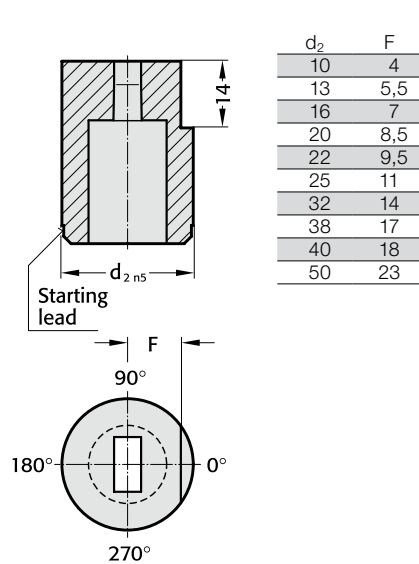

Anti-rotation element 6 (6)

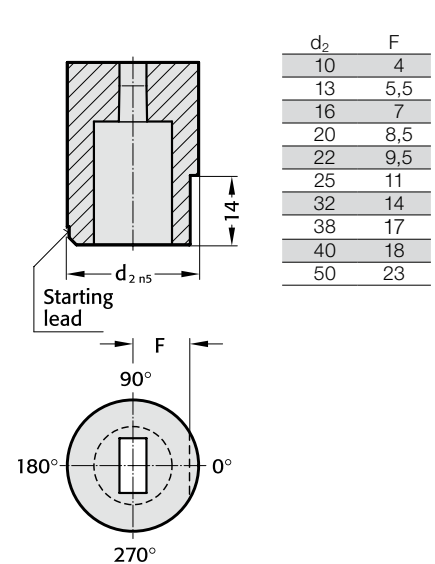

MATRIX WITHOUT SHOULDER, SLOT, ISO 8977



2646.

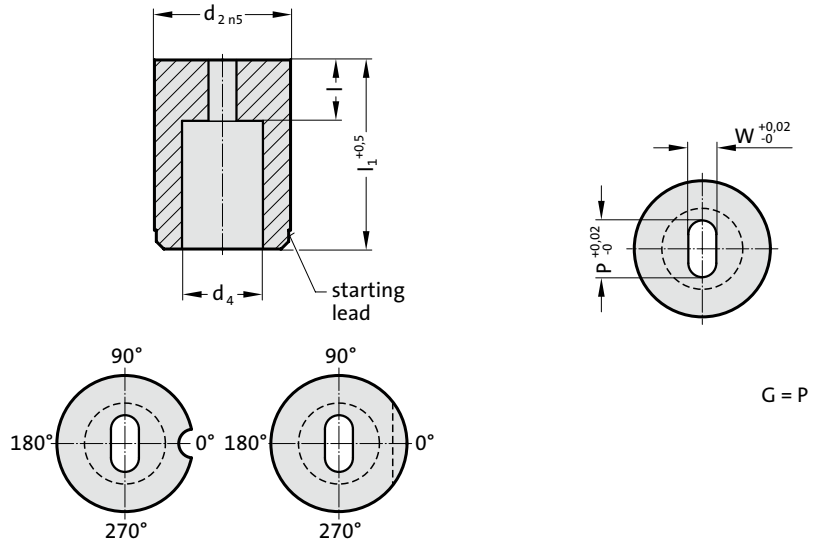

2646. Matrix without shoulder, slot, ISO 8977

d ₂ / Order No	d ₄	W _{min}	G _{max}	l / Order No	l ₁ / (Order Code character)	16 (B)	20 (C)	22 (D)	25 (E)	28 (F)	30 (G)	32 (H)	35 (J)	40 (K)
10 / (4)	5.8	1.2	5	4 (3) 8 (6)		●	●	●	●	●	●	●	●	●
13 / (5)	8	2	7	5 (4) 8 (6)			●	●	●	●	●	●	●	●
16 / (6)	9.5	2.4	9	5 (4) 8 (6)			●	●	●	●	●	●	●	●
20 / (7)	12	3.2	11	8 (6) 12 (8)			●	●	●	●	●	●	●	●
22 / (8)	15	4	14	8 (6) 12 (8)			●	●	●	●	●	●	●	●
25 / (9)	17.3	4.8	16	8 (6) 12 (8)			●	●	●	●	●	●	●	●
32 / (10)	20.7	5.5	20	8 (6) 12 (8)			●	●	●	●	●	●	●	●
38 / (11)	27.7	6.4	27	8 (6) 12 (8)					●	●	●	●	●	●
40 / (12)	27.7	6.4	27	8 (6) 12 (8)					●	●	●	●	●	●
50 / (14)	37	9	36	8 (6) 12 (8)					●	●	●	●	●	●

Material:

HSS
Hardness 62 ± 2 HRC

Execution:

Diameter d₂, starting lead and face surfaces ground.
Special dimensions on request.

Ordering Code (example): with anti-rotation element

2646.10F8.1350.0650.B2

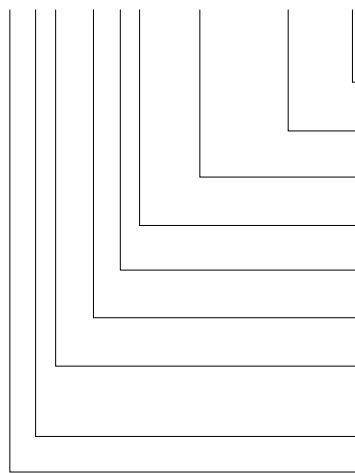

Anti-rotation element:
Pin Ø 4 mm
Angle:
90°
Shape: slot, Width W
W = 6,5 mm
Shape: slot, Length P
P = 13,5 mm
Shape cutting length: l
12 mm
Length: l₁
28 mm
Diameter: d₂
32 mm
Type:
without shoulder
ISO 8977
Execution:
slot
Matrix

Order No
= (2)
Order Code character
= (B)

= 0650

= 1350
Order No
= (8)
Order Code character
= (F)
Order No
= (10)
Order No
= (6)
Order No
= (4)
= 26

MATRIXES WITHOUT SHOULDER, CYLINDRICAL, ISO 8977, ANTI-ROTATION ELEMENTS

Anti-rotation element 1 (1)

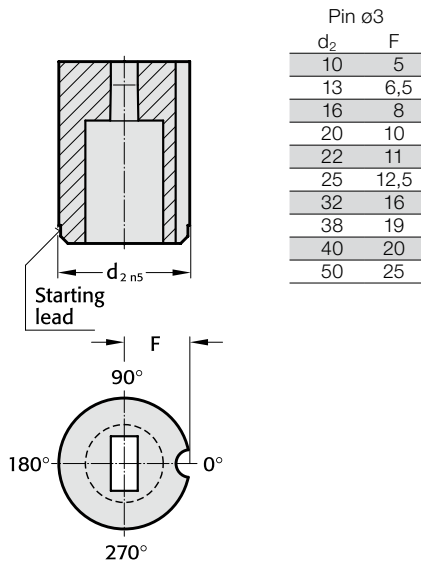

Anti-rotation element 2 (2)

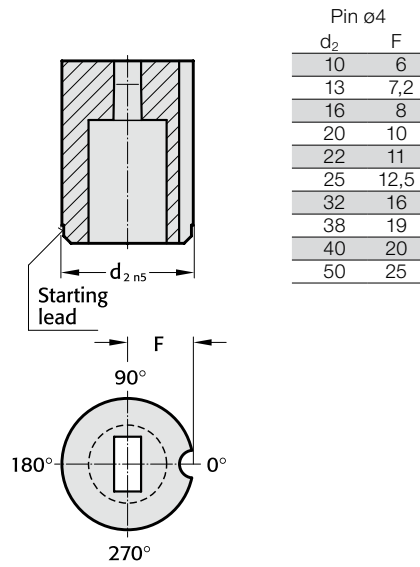

Anti-rotation element 3 (3)

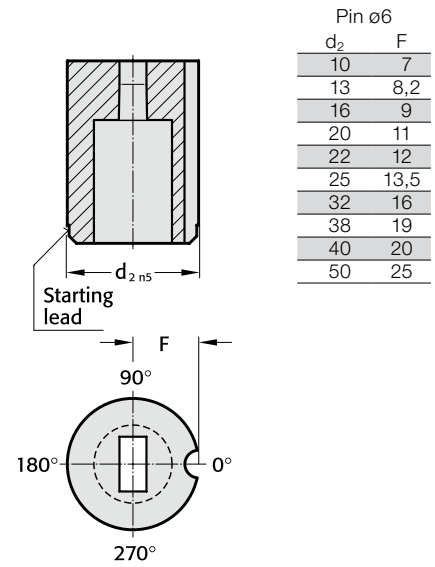

Anti-rotation element 4 (4)

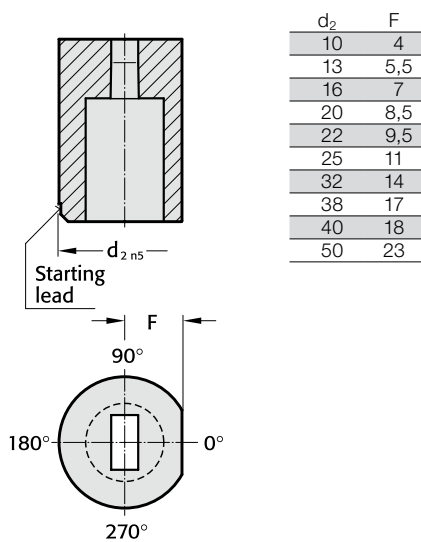

Anti-rotation element 5 (5)

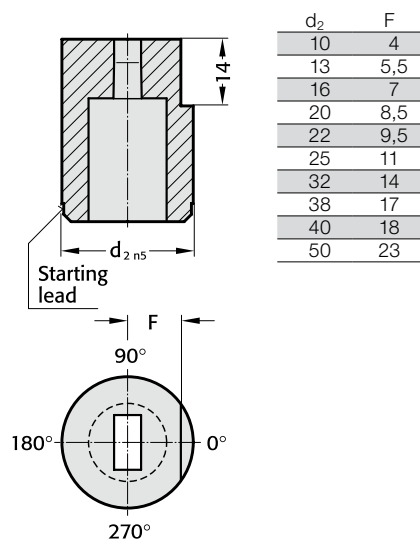

Anti-rotation element 6 (6)

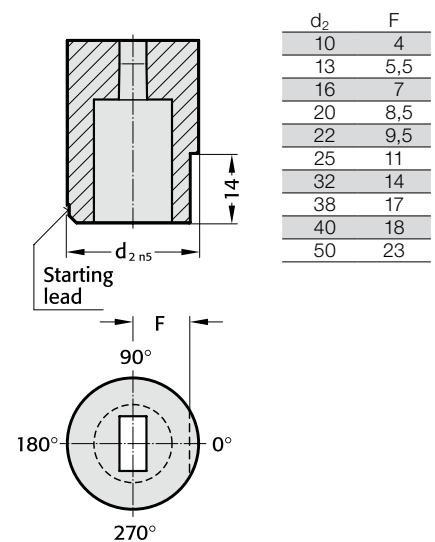

MATRIX WITHOUT SHOULDER, RECTANGLE WITH RADIUSSED CORNERS, ISO 8977



2656.

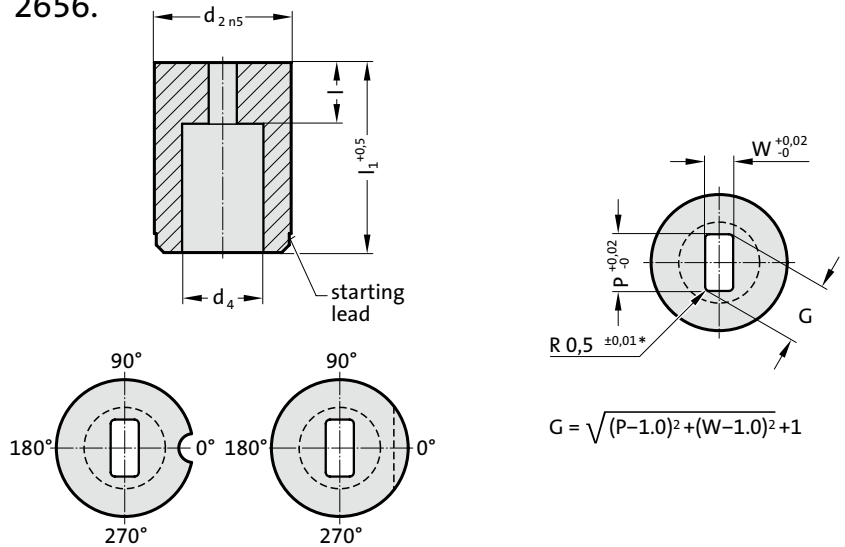

$$G = \sqrt{(P-1.0)^2 + (W-1.0)^2} + 1$$

2656. Matrix without shoulder, rectangle with radiussed corners, ISO 8977

d ₂ / Order No	d ₄	W _{min}	G _{max}	l / Order No	l ₁ / (Order Code character)	16 (B)	20 (C)	22 (D)	25 (E)	28 (F)	30 (G)	32 (H)	35 (J)	40 (K)
10 / (4)	5.8	1.2	5	4 (3) 8 (6)		●	●	●	●	●	●	●	●	●
13 / (5)	8	2	7	5 (4) 8 (6)			●	●	●	●	●	●	●	●
16 / (6)	9.5	2.4	9	5 (4) 8 (6)			●	●	●	●	●	●	●	●
20 / (7)	12	3.2	11	8 (6) 12 (8)			●	●	●	●	●	●	●	●
22 / (8)	15	4	14	8 (6) 12 (8)			●	●	●	●	●	●	●	●
25 / (9)	17.3	4.8	16	8 (6) 12 (8)			●	●	●	●	●	●	●	●
32 / (10)	20.7	5.5	20	8 (6) 12 (8)			●	●	●	●	●	●	●	●
38 / (11)	27.7	6.4	27	8 (6) 12 (8)					●	●	●	●	●	●
40 / (12)	27.7	6.4	27	8 (6) 12 (8)					●	●	●	●	●	●
50 / (14)	37	9	36	8 (6) 12 (8)					●	●	●	●	●	●

Material:

HSS
Hardness 62 ± 2 HRC

Execution:

Diameter d₂, starting lead and face surfaces ground.

Special dimensions on request.

* For other radius options, see standardised special shapes.

Ordering Code (example): with anti-rotation element

2656.10F8.1350.0650.A1

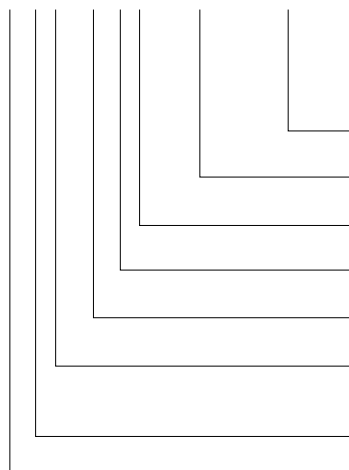

Anti-rotation element:

Pin Ø 3 mm

Angle:

0°

Shape: rectangle with radiussed corners, Width W

W = 6,5 mm

Shape: rectangle with radiussed corners, Length P

P = 13,5 mm

Shape cutting length: l

12 mm

Length: l₁

28 mm

Diameter: d₂

32 mm

Type:

without shoulder

ISO 8977

Execution:

rectangle with radiussed corners

Matrix

Order No

= (1)

Order Code character

= (A)

Order Code character

= (0650)

Order Code character

= (1350)

Order No

= (8)

Order Code character

= (F)

Order No

= (10)

Order No

= (6)

Order No

= (5)

Order No

= (26)

MATRIXES WITHOUT SHOULDER, CYLINDRICAL, ISO 8977, ANTI-ROTATION ELEMENTS

Anti-rotation element 1 (1)

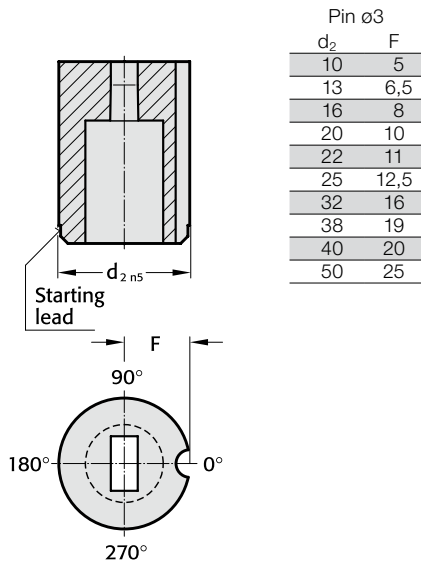

Anti-rotation element 2 (2)

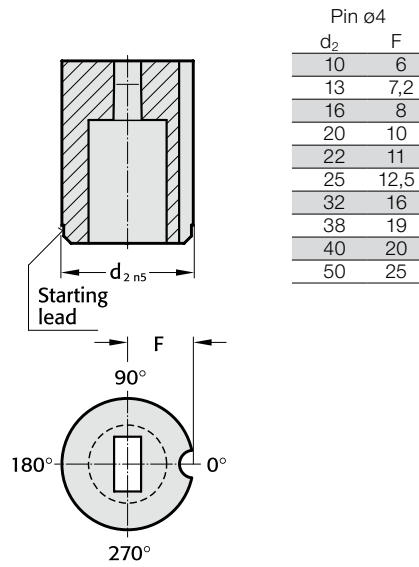

Anti-rotation element 3 (3)

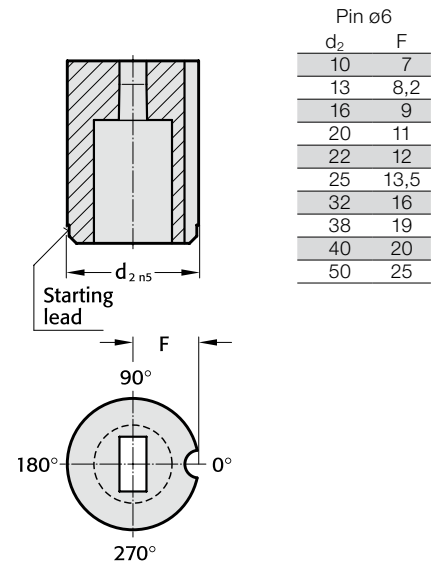

Anti-rotation element 4 (4)

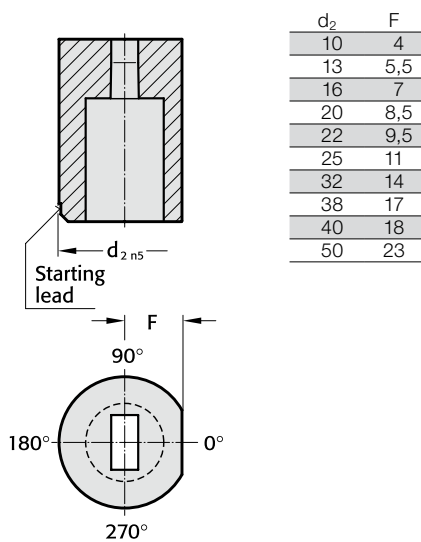

Anti-rotation element 5 (5)

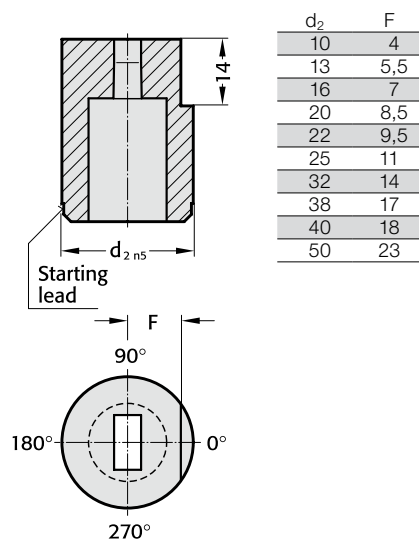

Anti-rotation element 6 (6)

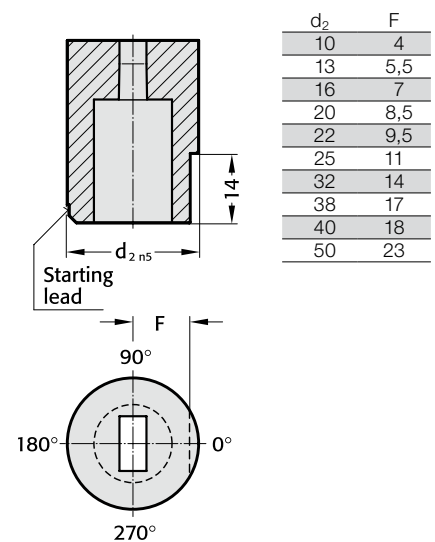

MATRIX WITH SHOULDER, BLANK, ISO 8977

2607.

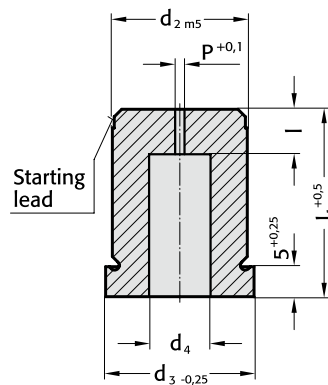

2607. Matrix with shoulder, blank, ISO 8977

d ₂ / Order No	d ₃	d ₄	P	l / Order No	l ₁ / (Order Code character)	16 (B)	20 (C)	22 (D)	25 (E)	28 (F)	30 (G)	32 (H)	35 (J)
5 / (1)	8	2.8	0.8	2 (1)		●	●	●	●	●	●	●	●
6 / (2)	9	3.5	1	3 (2)		●	●	●	●	●	●	●	●
8 / (3)	11	4	1	4 (3)		●	●	●	●	●	●	●	●
10 / (4)	13	5.8	1	4 (3) 8 (6)		●	●	●	●	●	●	●	●
13 / (5)	16	8	1.2	5 (4) 8 (6)			●	●	●	●	●	●	●
16 / (6)	19	9.5	1.2	5 (4) 8 (6)			●	●	●	●	●	●	●
20 / (7)	23	12	1.5	8 (6) 12 (8)			●	●	●	●	●	●	●
22 / (8)	25	15	1.5	8 (6) 12 (8)			●	●	●	●	●	●	●
25 / (9)	28	17.3	1.5	8 (6) 12 (8)			●	●	●	●	●	●	●
32 / (10)	35	20.7	1.5	8 (6) 12 (8)			●	●	●	●	●	●	●
38 / (11)	41	27.7	1.5	8 (6) 12 (8)			●	●	●	●	●	●	●
40 / (12)	43	27.7	1.5	8 (6) 12 (8)			●	●	●	●	●	●	●
50 / (14)	53	37	1.5	8 (6) 12 (8)			●	●	●	●	●	●	●

Ordering Code (example):

2607.11E6

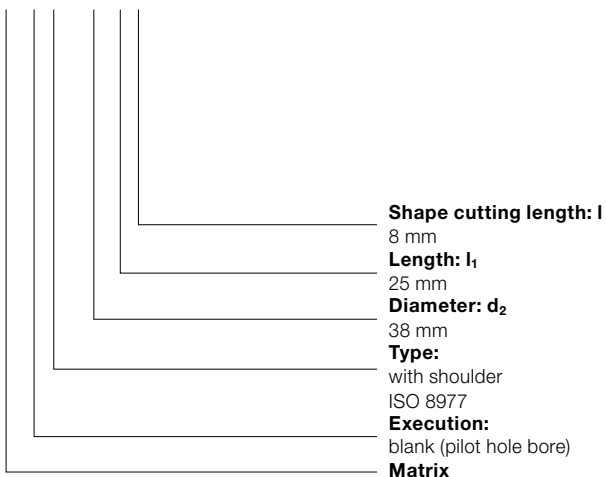

Order No
 = (6)
Order Code character
 = (E)
Order No
 = (11)
Order No
 = (7)
Order No
 = (0)
Matrix
 = 26

Material:

HSS
 Hardness 62 ± 2 HRC

Execution:

Diameter d₂, starting lead and face surfaces ground.
 Diameter P is a bored pilot hole for wire EDM.
 Special dimensions on request.

MATRIX WITH SHOULDER, ROUND, ISO 8977



2617.

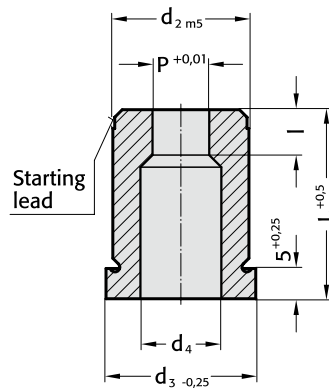

2617. Matrix with shoulder, round, ISO 8977

d ₂ / Order No	d ₃	d ₄	P	l / Order No	l ₁ / (Order Code character)	16 (B)	20 (C)	22 (D)	25 (E)	28 (F)	30 (G)	32 (H)	35 (J)
5 / (1)	8	2.8	1 - 2,4	2 (1)		●	●	●	●	●	●	●	●
6 / (2)	9	3.5	1,6 - 3	3 (2)		●	●	●	●	●	●	●	●
8 / (3)	11	4	2 - 3,5	4 (3)		●	●	●	●	●	●	●	●
10 / (4)	13	5.8	2,5 - 5	4 (3) 8 (6)		●	●	●	●	●	●	●	●
13 / (5)	16	8	4 - 7	5 (4) 8 (6)			●	●	●	●	●	●	●
16 / (6)	19	9.5	6 - 9	5 (4) 8 (6)			●	●	●	●	●	●	●
20 / (7)	23	12	8 - 11	8 (6) 12 (8)			●	●	●	●	●	●	●
22 / (8)	25	15	9 - 14	8 (6) 12 (8)			●	●	●	●	●	●	●
25 / (9)	28	17.3	10,7 - 16	8 (6) 12 (8)			●	●	●	●	●	●	●
32 / (10)	35	20.7	15 - 20	8 (6) 12 (8)			●	●	●	●	●	●	●
38 / (11)	41	27.7	19 - 27	8 (6) 12 (8)			●	●	●	●	●	●	●
40 / (12)	43	27.7	19 - 27	8 (6) 12 (8)			●	●	●	●	●	●	●
50 / (14)	53	37	26 - 36	8 (6) 12 (8)			●	●	●	●	●	●	●

Material:

HSS
Hardness 62 ± 2 HRC

Execution:

Diameter d₂, starting lead and face surfaces ground.
Special dimensions on request.

Ordering Code (example): without anti-rotation element

2617.10F8.1510

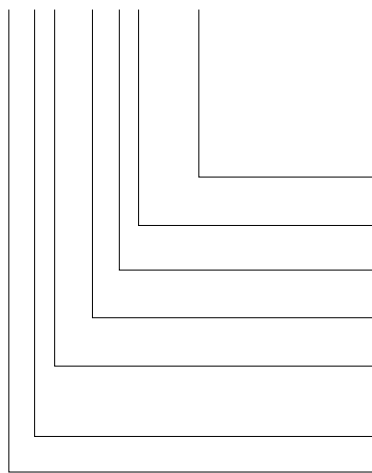

Shape: round
P = ø15,1 mm
Shape cutting length: l
12 mm
Length: l₁
28 mm
Diameter: d₂
32 mm
Type:
with shoulder
ISO 8977
Execution:
round
Matrix

= 1510
Order No
= (8)
Order Code character
= (F)
Order No
= (10)
Order No
= (7)
Order No
= (1)
= 26

MATRIXES WITH SHOULDER, CYLINDRICAL, ISO 8977, ANTI-ROTATION ELEMENTS

Anti-rotation element 1 (1)

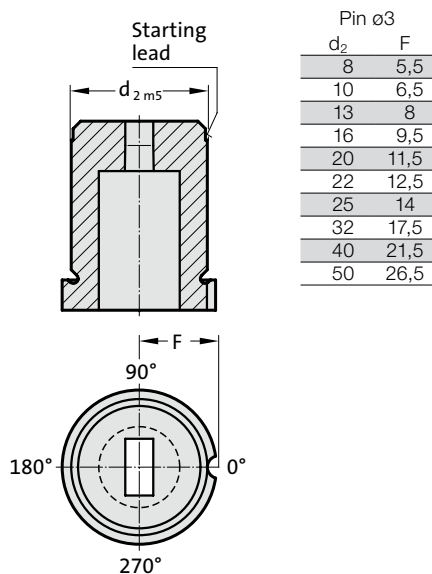

Anti-rotation element 2 (2)

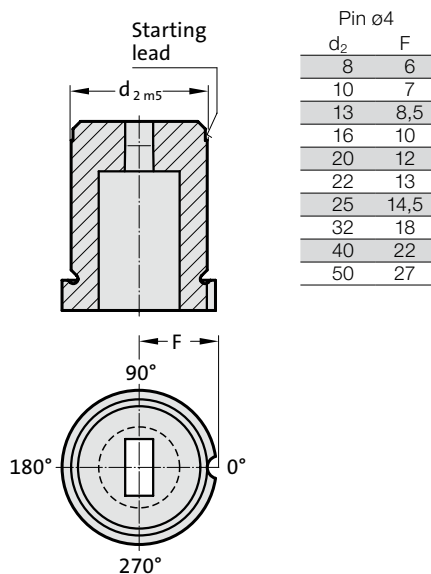

Anti-rotation element 3 (3)

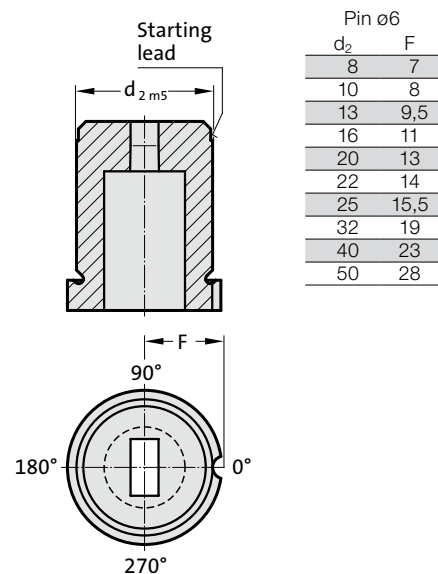

Anti-rotation element 4 (4)

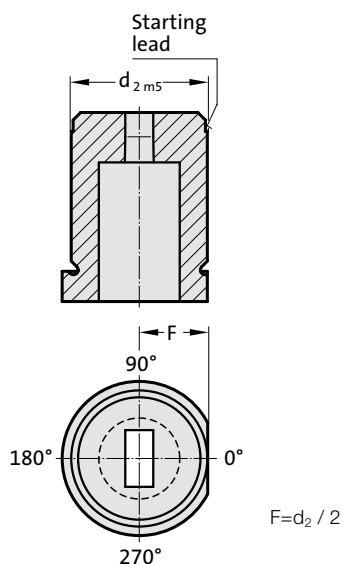

Ordering Code (example): with anti-rotation element from $d_2 \geq 8$ mm

2617.10F8.1510.A4

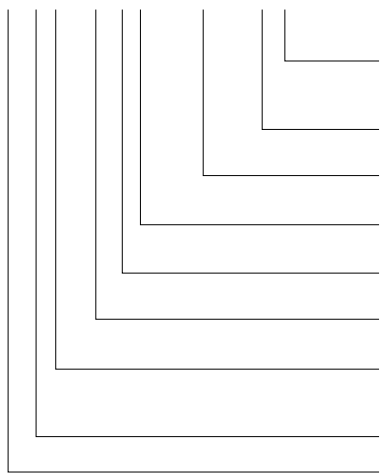

Anti-rotation element:
Polished surface
(continuous)
Angle:
 0°
Shape: round
 $P = \varnothing 15,1$ mm
Shape cutting length: l
12 mm
Length: l_1
28 mm
Diameter: d_2
32 mm
Type:
with shoulder
ISO 8977
Execution:
round
Matrix

Order No
= (4)
Order Code character
= (A)
= 1510
Order No
= (8)
Order Code character
= (F)
Order No
= (10)
Order No
= (7)
Order No
= (1)
= 26

MATRIX WITH SHOULDER, SQUARE, ISO 8977



2627.

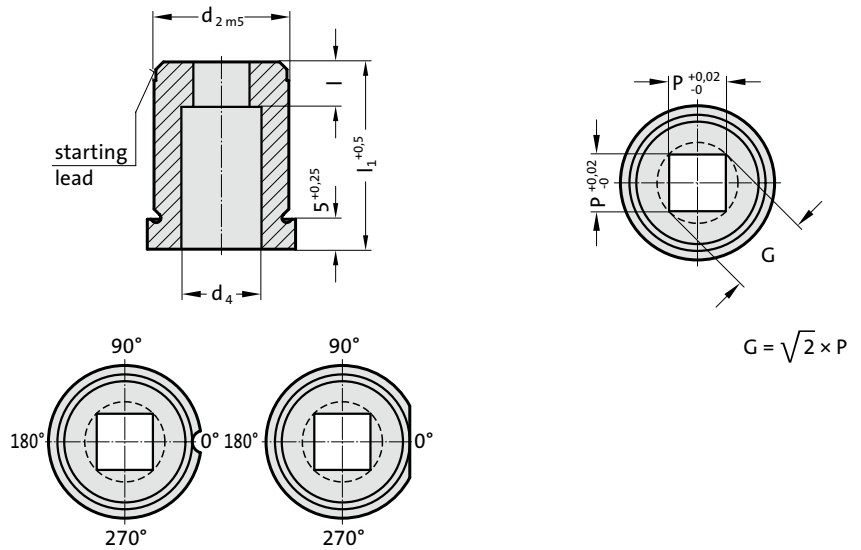

2627. Matrix with shoulder, square, ISO 8977

d ₂ / Order No	d ₃	d ₄	P _{min}	G _{max}	l / Order No	l ₁ / (Order Code character)	16 (B)	20 (C)	22 (D)	25 (E)	28 (F)	30 (G)	32 (H)	35 (J)
8 / (3)	11	4	1.2	3.5	4 (3)		●	●	●	●	●	●	●	●
10 / (4)	13	5.8	1.2	5	4 (3) 8 (6)		●	●	●	●	●	●	●	●
13 / (5)	16	8	2	7	5 (4) 8 (6)		●	●	●	●	●	●	●	●
16 / (6)	19	9.5	2.4	9	5 (4) 8 (6)		●	●	●	●	●	●	●	●
20 / (7)	23	12	3.2	11	8 (6) 12 (8)		●	●	●	●	●	●	●	●
22 / (8)	25	15	4	14	8 (6) 12 (8)		●	●	●	●	●	●	●	●
25 / (9)	28	17.3	4.8	16	8 (6) 12 (8)		●	●	●	●	●	●	●	●
32 / (10)	35	20.7	5.5	20	8 (6) 12 (8)		●	●	●	●	●	●	●	●
38 / (11)	41	27.7	6.4	27	8 (6) 12 (8)		●	●	●	●	●	●	●	●
40 / (12)	43	27.7	6.4	27	8 (6) 12 (8)		●	●	●	●	●	●	●	●
50 / (14)	53	37	6.4	36	8 (6) 12 (8)		●	●	●	●	●	●	●	●

Material:

HSS
Hardness 62 ± 2 HRC

Execution:

Diameter d₂, starting lead and face surfaces ground.
Special dimensions on request.

Note:

With kerf ≤ 0.04 mm, FIBRO rounds off sharp edges if the punch and piercing die bush are ordered together. This reduces the fitting time and the risk of an edge break during operation.

Ordering Code (example): with anti-rotation element

2627.10F8.1350.A3

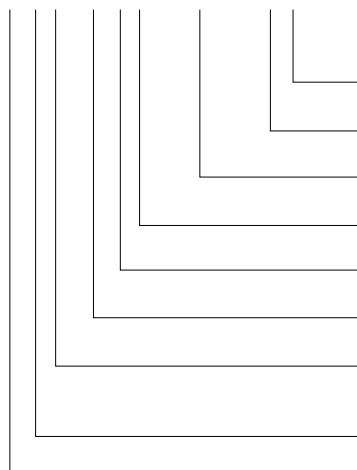

Anti-rotation element:

Pin Ø 6 mm

Angle:

0°

Shape: square, Length P

P = 13,5 mm

Shape cutting length: l

12 mm

Length: l₁

28 mm

Diameter: d₂

32 mm

Type:

with shoulder

ISO 8977

Execution:

square

Matrix

Order No

= (3)

Order Code character

= (A)

= 1350

Order No

= (8)

Order Code character

= (F)

Order No

= (10)

Order No

= (7)

Order No

= (2)

= 26

MATRIXES WITH SHOULDER, CYLINDRICAL, ISO 8977, ANTI-ROTATION ELEMENTS

Anti-rotation element 1 (1)

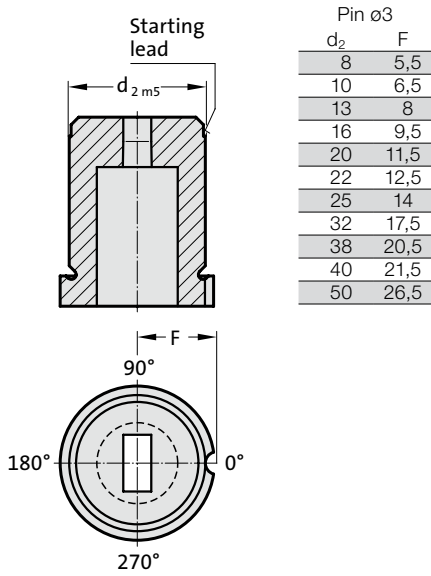

Anti-rotation element 2 (2)

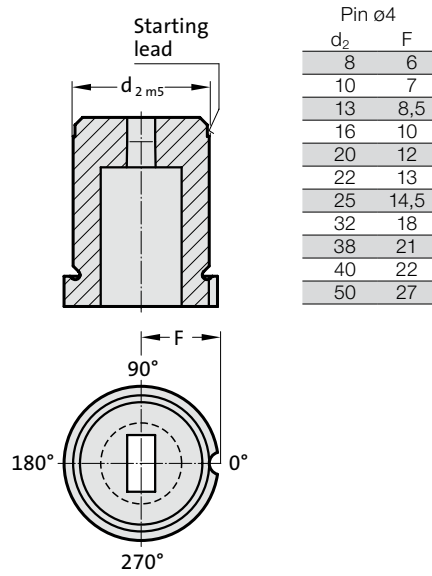

Anti-rotation element 3 (3)

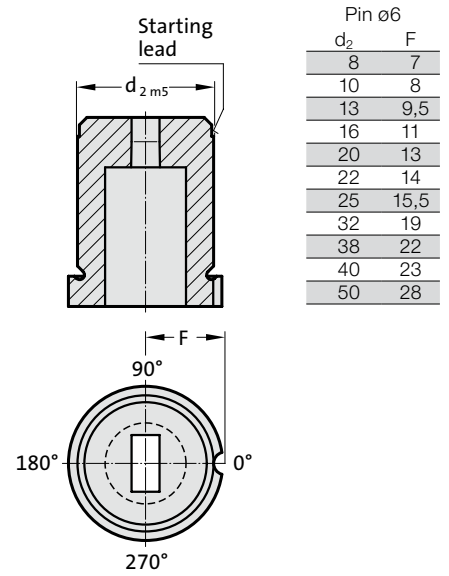

Anti-rotation element 4 (4)

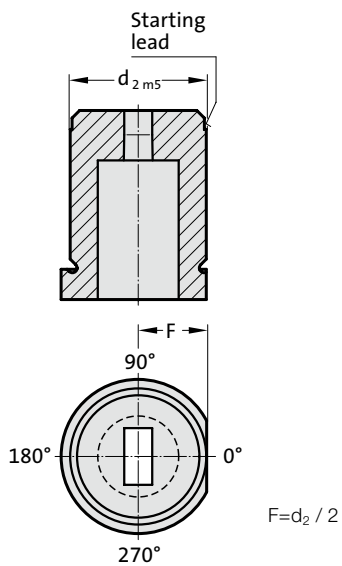

MATRIX WITH SHOULDER, RECTANGULAR, ISO 8977



2637.

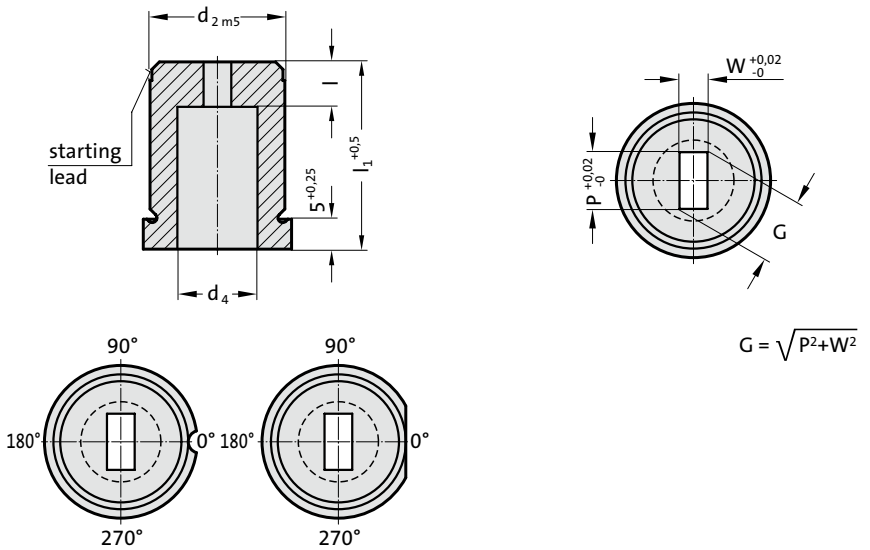

2637. Matrix with shoulder, rectangular, ISO 8977

d ₂ / Order No	d ₃	d ₄	W _{min}	G _{max}	l / Order No	l ₁ / (Order Code character)	16 (B)	20 (C)	22 (D)	25 (E)	28 (F)	30 (G)	32 (H)	35 (J)
8 / (3)	11	4	1.2	3.5	4 (3)		●	●	●	●	●	●	●	●
10 / (4)	13	5.8	1.2	5	4 (3) 8 (6)		●	●	●	●	●	●	●	●
13 / (5)	16	8	2	7	5 (4) 8 (6)		●	●	●	●	●	●	●	●
16 / (6)	19	9.5	2.4	9	5 (4) 8 (6)		●	●	●	●	●	●	●	●
20 / (7)	23	12	3.2	11	8 (6) 12 (8)		●	●	●	●	●	●	●	●
22 / (8)	25	15	4	14	8 (6) 12 (8)		●	●	●	●	●	●	●	●
25 / (9)	28	17.3	4.8	16	8 (6) 12 (8)		●	●	●	●	●	●	●	●
32 / (10)	35	20.7	5.5	20	8 (6) 12 (8)		●	●	●	●	●	●	●	●
38 / (11)	41	27.7	6.4	27	8 (6) 12 (8)		●	●	●	●	●	●	●	●
40 / (12)	43	27.7	6.4	27	8 (6) 12 (8)		●	●	●	●	●	●	●	●
50 / (14)	53	37	6.4	36	8 (6) 12 (8)		●	●	●	●	●	●	●	●

Material:

HSS
Hardness 62 ± 2 HRC

Execution:

Diameter d₂, starting lead and face surfaces ground.
Special dimensions on request.

Note:

With kerf ≤ 0.04 mm, FIBRO rounds off sharp edges if the punch and piercing die bush are ordered together. This reduces the fitting time and the risk of an edge break during operation.

Ordering Code (example): with anti-rotation element

2637.10F8.1350.0650.B2

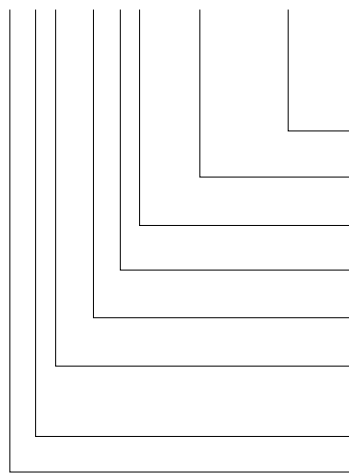

Anti-rotation element:

Pin Ø 4 mm

Angle:

90°

Shape: rectangular, Width W

W = 6,5 mm

Shape: rectangular, Length P

P = 13,5 mm

Shape cutting length: l

12 mm

Length: l₁

28 mm

Diameter: d₂

32 mm

Type:

with shoulder

ISO 8977

Execution:

rectangular

Matrix

Order No

= (2)

Order Code character

= (B)

= 0650

= 1350

Order No

= (8)

Order Code character

= (F)

Order No

= (10)

Order No

= (7)

Order No

= (3)

= 26

MATRIXES WITH SHOULDER, CYLINDRICAL, ISO 8977, ANTI-ROTATION ELEMENTS

Anti-rotation element 1 (1)

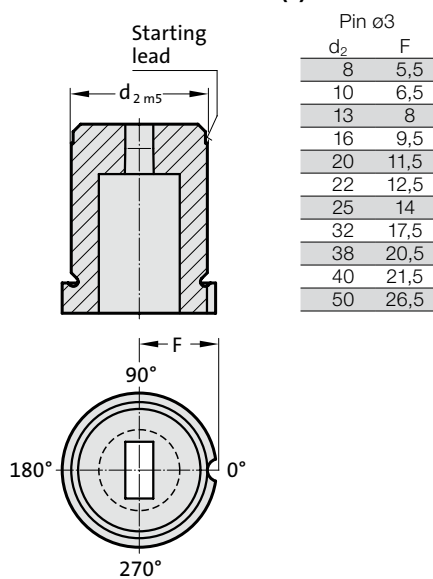

Anti-rotation element 2 (2)

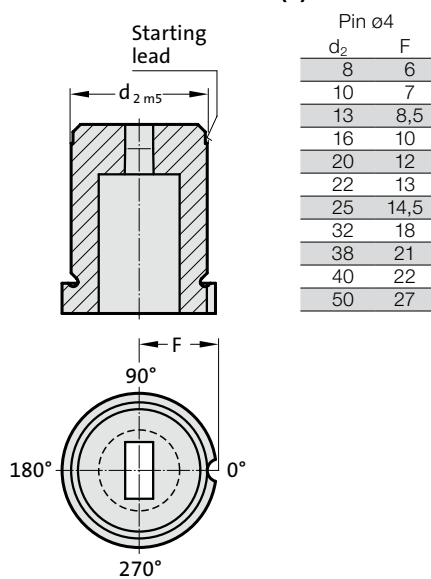

Anti-rotation element 3 (3)

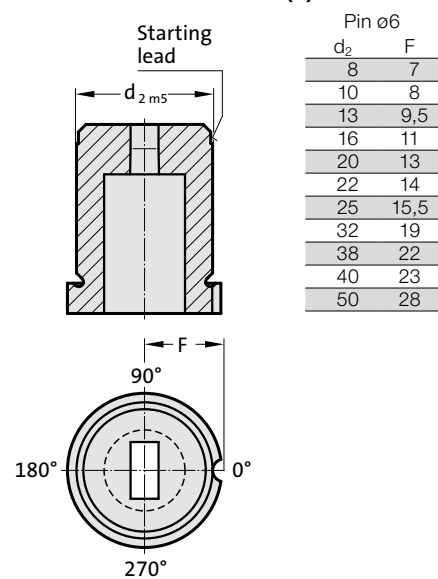

Anti-rotation element 4 (4)

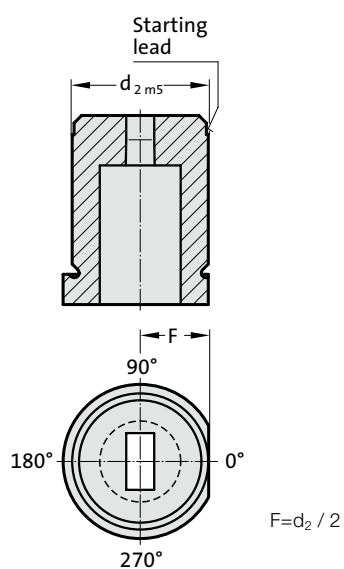

MATRIX WITH SHOULDER, SLOT, ISO 8977



2647.

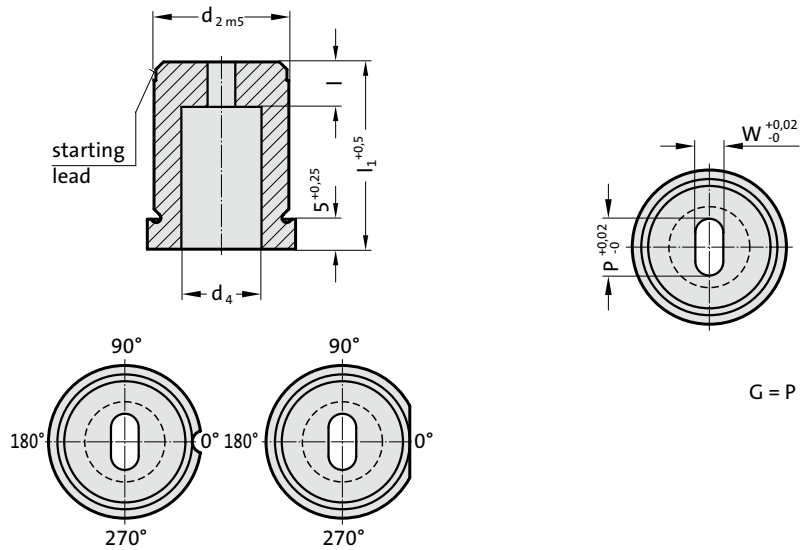

2647. Matrix with shoulder, slot, ISO 8977

d ₂ / Order No	d ₃	d ₄	W _{min}	G _{max}	l / Order No	l ₁ / (Order Code character)	16 (B)	20 (C)	22 (D)	25 (E)	28 (F)	30 (G)	32 (H)	35 (J)
8 / (3)	11	4	1.2	3.5	4 (3)		●	●	●	●	●	●	●	●
10 / (4)	13	5.8	1.2	5	4 (3) 8 (6)		●	●	●	●	●	●	●	●
13 / (5)	16	8	2	7	5 (4) 8 (6)		●	●	●	●	●	●	●	●
16 / (6)	19	9.5	2.4	9	5 (4) 8 (6)		●	●	●	●	●	●	●	●
20 / (7)	23	12	3.2	11	8 (6) 12 (8)		●	●	●	●	●	●	●	●
22 / (8)	25	15	4	14	8 (6) 12 (8)		●	●	●	●	●	●	●	●
25 / (9)	28	17.3	4.8	16	8 (6) 12 (8)		●	●	●	●	●	●	●	●
32 / (10)	35	20.7	5.5	20	8 (6) 12 (8)		●	●	●	●	●	●	●	●
38 / (11)	41	27.7	6.4	27	8 (6) 12 (8)		●	●	●	●	●	●	●	●
40 / (12)	43	27.7	6.4	27	8 (6) 12 (8)		●	●	●	●	●	●	●	●
50 / (14)	53	37	6.4	36	8 (6) 12 (8)		●	●	●	●	●	●	●	●

Material:

HSS
Hardness 62 ± 2 HRC

Execution:

Diameter d₂, starting lead and face surfaces ground.
Special dimensions on request.

Ordering Code (example): with anti-rotation element

2647.10F8.1350.0650.A3

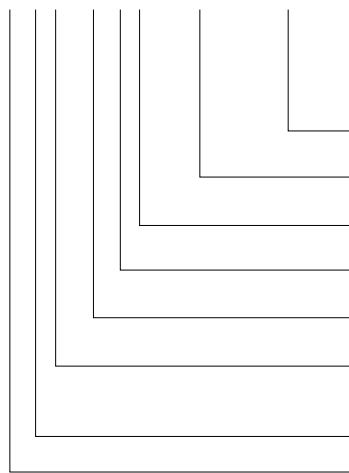

Anti-rotation element:
Pin Ø 6 mm
Angle:
0°
Shape: slot, Width W
W = 6,5 mm
Shape: slot, Length P
P = 13,5 mm
Shape cutting length: l
12 mm
Length: l₁
28 mm
Diameter: d₂
32 mm
Type:
with shoulder
ISO 8977
Execution:
slot
Matrix

Order No
= (3)
Order Code character
= (A)
= 0650
= 1350
Order No
= (8)
Order Code character
= (F)
Order No
= (10)
Order No
= (7)
Order No
= (4)
= 26

MATRIXES WITH SHOULDER, CYLINDRICAL, ISO 8977, ANTI-ROTATION ELEMENTS

Anti-rotation element 1 (1)

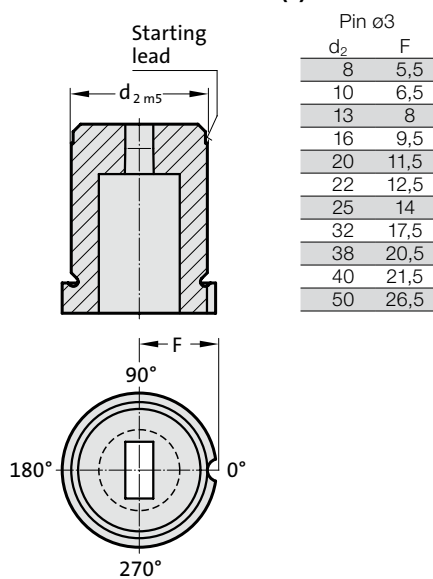

Anti-rotation element 2 (2)

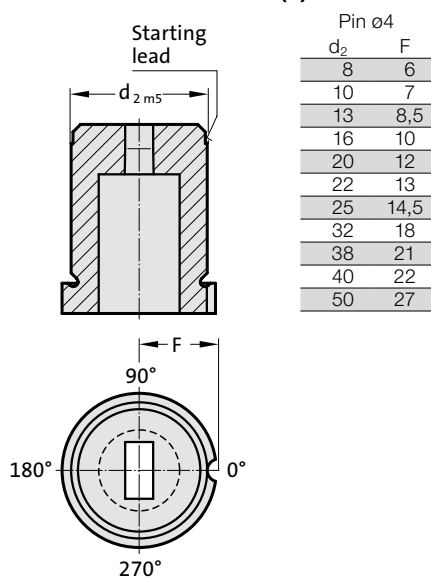

Anti-rotation element 3 (3)

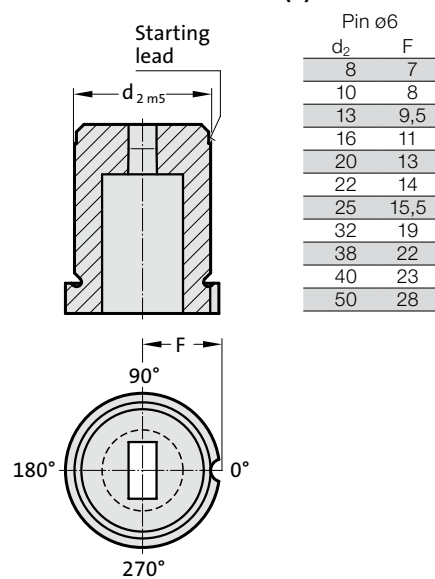

Anti-rotation element 4 (4)

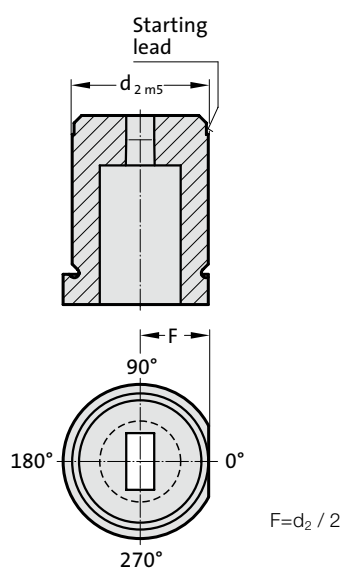

MATRIX WITH SHOULDER, RECTANGLE WITH RADIUSSED CORNERS, ISO 8977



2657.

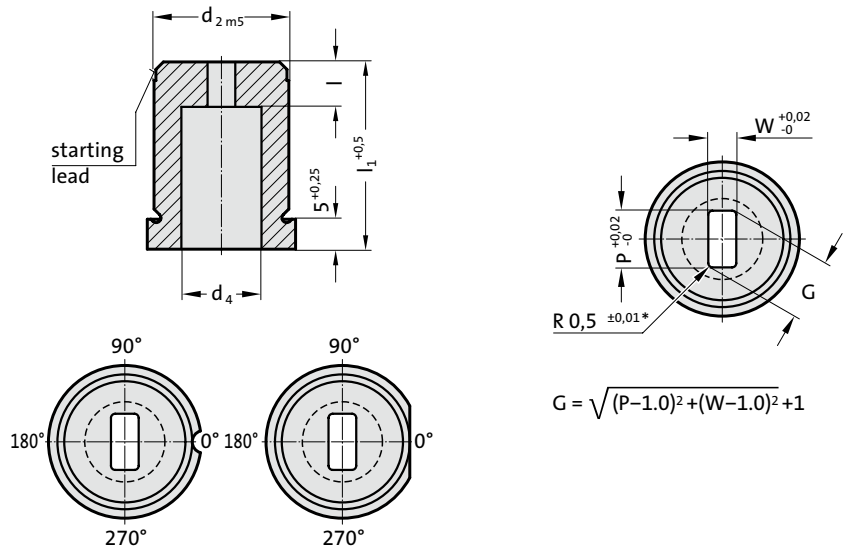

$$G = \sqrt{(P-1.0)^2 + (W-1.0)^2} + 1$$

2657. Matrix with shoulder, rectangle with radiused corners, ISO 8977

d ₂ / Order No	d ₃	d ₄	W _{min}	G _{max}	l / Order No	l ₁ / (Order Code character)	16 (B)	20 (C)	22 (D)	25 (E)	28 (F)	30 (G)	32 (H)	35 (J)
8 / (3)	11	4	1.2	3.5	4 (3)		●	●	●	●	●	●	●	●
10 / (4)	13	5.8	1.2	5	4 (3) 8 (6)		●	●	●	●	●	●	●	●
13 / (5)	16	8	2	7	5 (4) 8 (6)		●	●	●	●	●	●	●	●
16 / (6)	19	9.5	2.4	9	5 (4) 8 (6)		●	●	●	●	●	●	●	●
20 / (7)	23	12	3.2	11	8 (6) 12 (8)		●	●	●	●	●	●	●	●
22 / (8)	25	15	4	14	8 (6) 12 (8)		●	●	●	●	●	●	●	●
25 / (9)	28	17.3	4.8	16	8 (6) 12 (8)		●	●	●	●	●	●	●	●
32 / (10)	35	20.7	5.5	20	8 (6) 12 (8)		●	●	●	●	●	●	●	●
38 / (11)	41	27.7	6.4	27	8 (6) 12 (8)		●	●	●	●	●	●	●	●
40 / (12)	43	27.7	6.4	27	8 (6) 12 (8)		●	●	●	●	●	●	●	●
50 / (14)	53	37	6.4	36	8 (6) 12 (8)		●	●	●	●	●	●	●	●

Material:

HSS
Hardness 62 ± 2 HRC

Execution:

Diameter d₂, starting lead and face surfaces ground.

Special dimensions on request.

* For other radius options, see standardised special shapes.

Ordering Code (example): with anti-rotation element

2657.10F8.1350.0650.A1

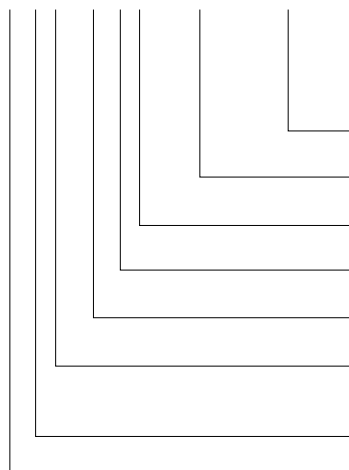

Anti-rotation element:

Pin Ø 3 mm

Angle:

0°

Shape: rectangle with radiused corners, Width W

W = 6,5 mm

Shape: rectangle with radiused corners, Length P

P = 13,5 mm

Shape cutting length: l

12 mm

Length: l₁

28 mm

Diameter: d₂

32 mm

Type:

with shoulder

ISO 8977

Execution:

rectangle with radiused corners

Matrix

Order No

= (3)

Order Code character

= (A)

Order Code character

= 0650

Order Code character

= 1350

Order No

= (8)

Order Code character

= (F)

Order No

= (10)

Order No

= (7)

Order No

= (5)

Order No

= 26

MATRIXES WITH SHOULDER, CYLINDRICAL, ISO 8977, ANTI-ROTATION ELEMENTS

Anti-rotation element 1 (1)

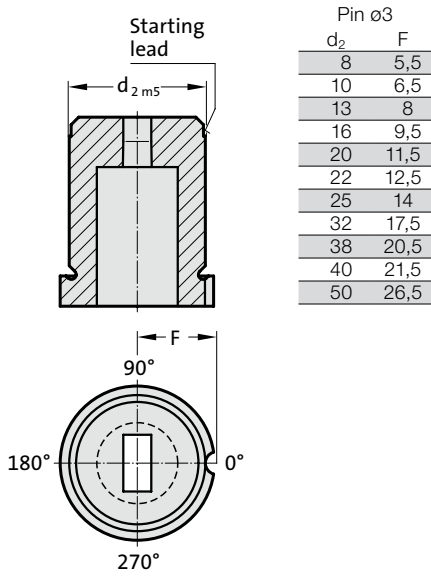

Anti-rotation element 2 (2)

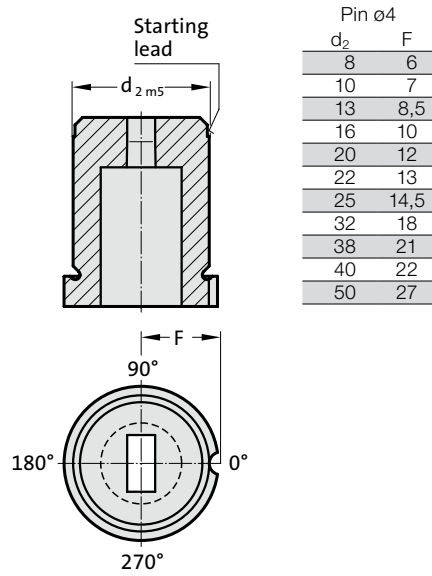

Anti-rotation element 3 (3)

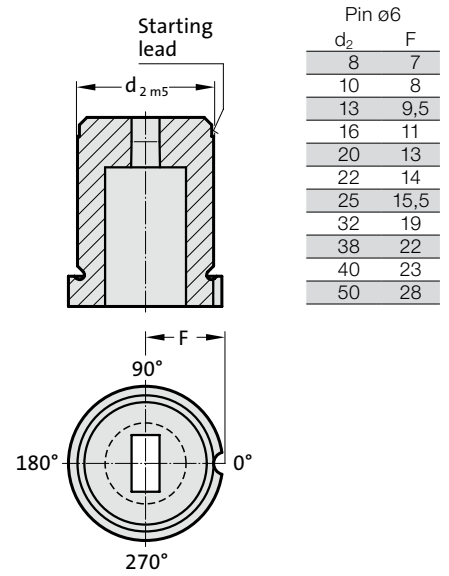

Anti-rotation element 4 (4)

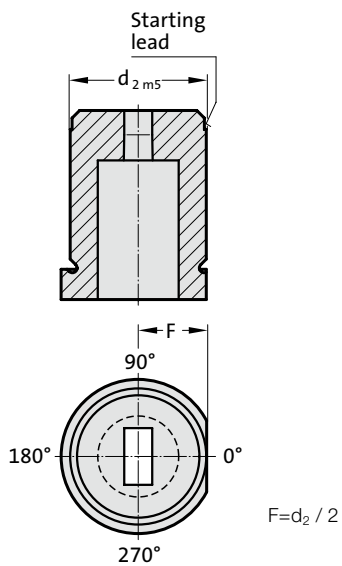

MATRIX WITHOUT SHOULDER, BLANK, AUTOMOTIVE STANDARD



2605.

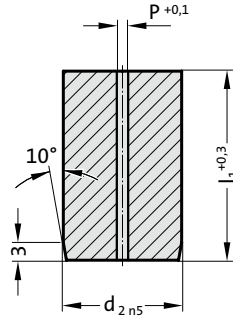

2605. Matrix without shoulder, blank, Automotive Standard

d ₂ / Order No	P	l ₁ / (Order Code character)	13 (A)	16 (B)	20 (C)	22 (D)	25 (E)	28 (F)	30 (G)	32 (H)	35 (J)	40 (K)
10 / (4)	0.8		●	●	●	●	●	●	●	●	●	
13 / (5)	0.8		●	●	●	●	●	●	●	●	●	
16 / (6)	1.5				●	●	●	●	●	●	●	
20 / (7)	1.5				●	●	●	●	●	●	●	
22 / (8)	1.5					●	●	●	●	●	●	
25 / (9)	1.5					●	●	●	●	●	●	
32 / (10)	1.5					●	●	●	●	●	●	
38 / (11)	1.5				●	●	●	●	●	●	●	●
40 / (12)	1.5					●	●	●	●	●	●	●
45 / (13)	1.5					●	●	●	●	●	●	●
50 / (14)	1.5					●	●	●	●	●	●	●
56 / (15)	1.5					●	●	●	●	●	●	●
63 / (16)	1.5					●	●	●	●	●	●	●
71 / (17)	1.5					●	●	●	●	●	●	●
76 / (18)	1.5						●	●	●	●	●	●
85 / (19)	1.5						●	●	●	●	●	●
90 / (20)	1.5						●	●	●	●	●	●
100 / (21)	1.5						●	●	●	●	●	●

Material:

HSS
Hardness 62 ± 2 HRC

Execution:

Diameter d₂ and face surfaces ground.
Diameter P is a bored pilot hole for wire EDM.
Special dimensions on request.

Ordering Code (example):

2605.10F

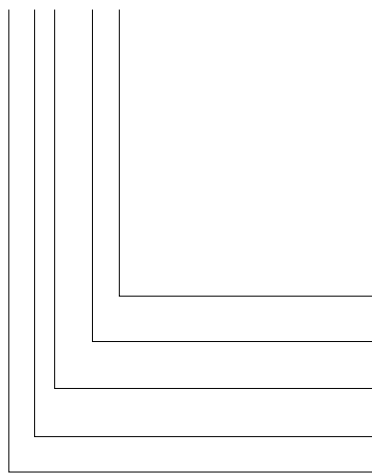

Length: l
28 mm
Diameter: d₂
32 mm
Type: without shoulder
Automotive Standard
Execution:
Blank (pilot hole bore)
Matrix

Order Code character
= (F)
Order No
= (10)
Order No
= (5)
Order No
= (0)
Matrix
= 26

MATRIX WITHOUT SHOULDER, ROUND, AUTOMOTIVE STANDARD



2615.

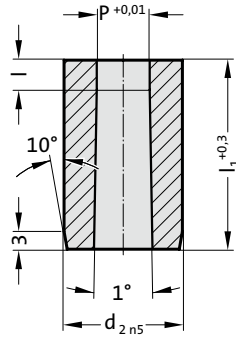

2615. Matrix without shoulder, round, Automotive Standard

d ₂ / Order No	P	l / Order No	l ₁ / (Order Code character)	13 (A)	16 (B)	20 (C)	22 (D)	25 (E)	28 (F)	30 (G)	32 (H)	35 (J)	40 (K)
10 / (4)	1,6 - 6,8	3 (2) 4 (3) 5 (4)		●	●	●	●	●	●	●	●	●	
13 / (5)	3 - 8,8	3 (2) 5 (4) 8 (6)		●	●	●	●	●	●	●	●	●	
16 / (6)	7,4 - 10,8	3 (2) 5 (4) 8 (6)				●	●	●	●	●	●	●	
20 / (7)	9,5 - 13,6	3 (2) 5 (4) 10 (7)				●	●	●	●	●	●	●	
22 / (8)	10,5 - 15	3 (2) 6 (5) 10 (7)				●	●	●	●	●	●	●	
25 / (9)	12 - 17	3 (2) 6 (5) 10 (7)				●	●	●	●	●	●	●	
32 / (10)	16 - 22	3 (2) 6 (5) 12 (8)				●	●	●	●	●	●	●	
38 / (11)	18 - 27	3 (2) 8 (6) 12 (8)				●	●	●	●	●	●	●	●
40 / (12)	18 - 27	3 (2) 8 (6) 12 (8)					●	●	●	●	●	●	●
45 / (13)	18 - 35	3 (2) 8 (6) 12 (8)					●	●	●	●	●	●	●
50 / (14)	18 - 40	3 (2) 8 (6) 12 (8)					●	●	●	●	●	●	●
56 / (15)	18 - 45	3 (2) 8 (6) 12 (8)					●	●	●	●	●	●	●
63 / (16)	18 - 50	3 (2) 8 (6) 12 (8)					●	●	●	●	●	●	●
71 / (17)	18 - 56	3 (2) 8 (6) 12 (8)					●	●	●	●	●	●	●
76 / (18)	25 - 60	3 (2) 8 (6) 12 (8)						●	●	●	●	●	●
85 / (19)	25 - 66	3 (2) 8 (6) 12 (8)						●	●	●	●	●	●
90 / (20)	32 - 70	3 (2) 8 (6) 12 (8)						●	●	●	●	●	●
100 / (21)	32 - 78	3 (2) 8 (6) 12 (8)						●	●	●	●	●	●

Material:

HSS
Hardness 62 ± 2 HRC

Execution:

Diameter d₂ and end faces ground.
Special dimensions on request.

Ordering Code (example): without / with anti-rotation element

2615.10F8.2190/.A3

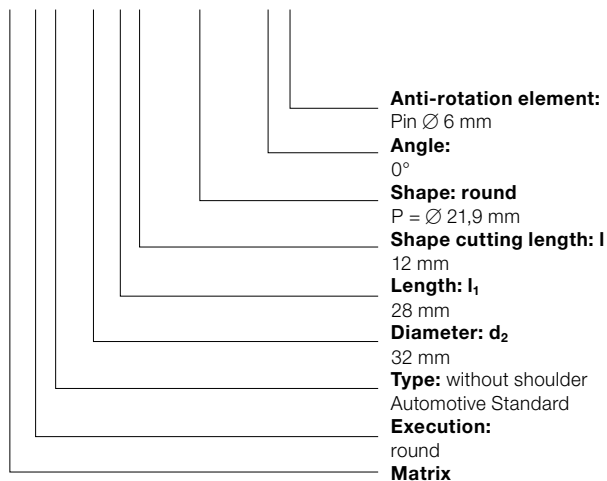

Anti-rotation element:

Pin Ø 6 mm

Angle:

0°

Shape: round

P = Ø 21,9 mm

Shape cutting length: l

12 mm

Length: l₁

28 mm

Diameter: d₂

32 mm

Type: without shoulder

Automotive Standard

Execution:

round

Matrix

Order No

= (3)

Order Code character

= (A)

= (2190)

Order No

= (8)

Order Code character

= (F)

Order No

= (10)

Order No

= (5)

Order No

= (1)

= 26

MATRIX WITHOUT SHOULDER, AUTOMOTIVE STANDARD, ANTI-ROTATION ELEMENTS

Anti-rotation element 1 (1)

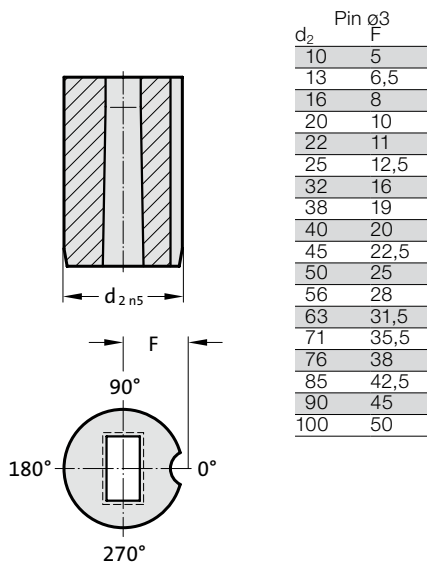

Anti-rotation element 2 (2)

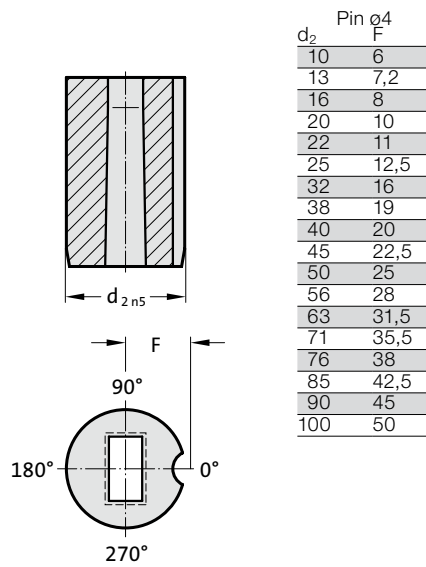

Anti-rotation element 3 (3)

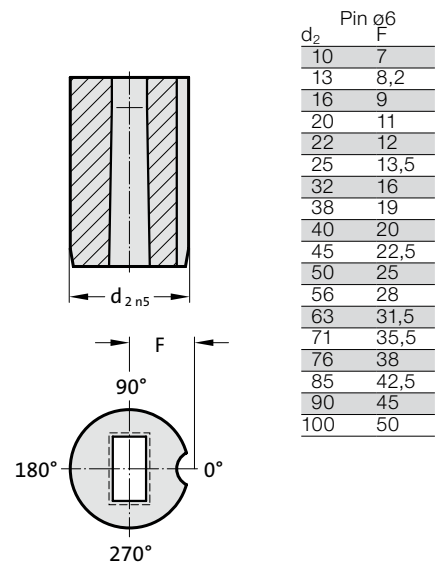

Anti-rotation element 4 (4)

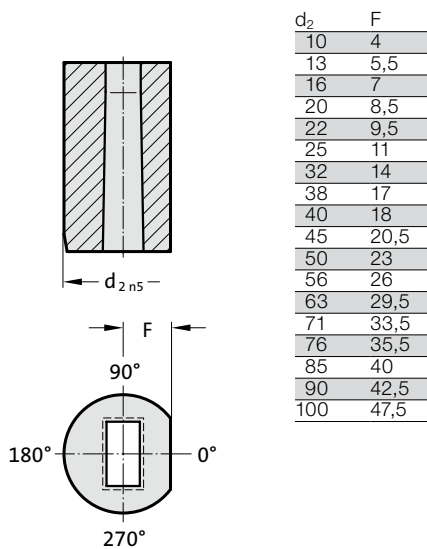

Anti-rotation element 5 (5)

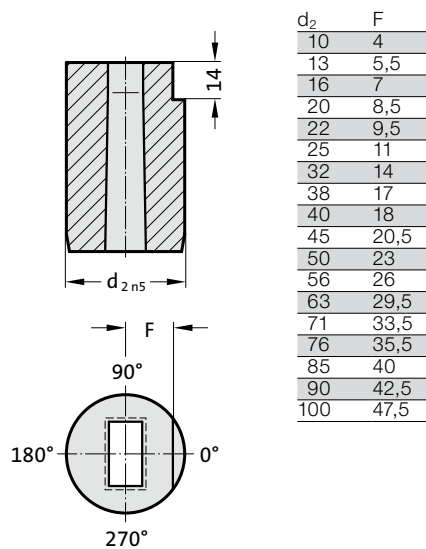

Anti-rotation element 6 (6)

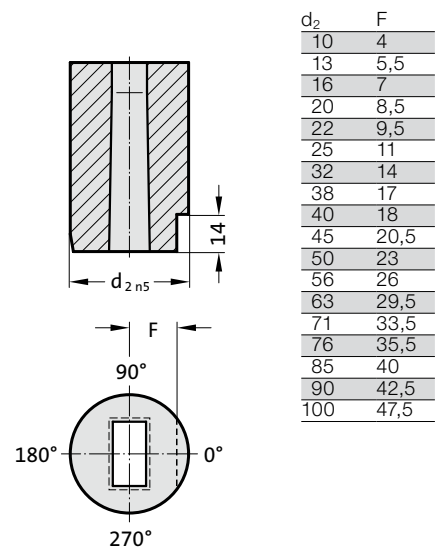

MATRIX WITHOUT SHOULDER, SQUARE, AUTOMOTIVE STANDARD



2625.

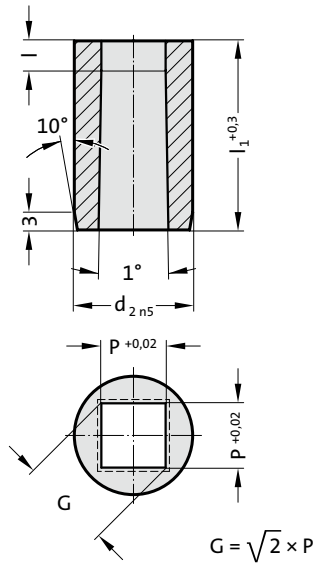

2625. Matrix without shoulder, square, Automotive Standard

d ₂ / Order No	P _{min}	G _{max}	l / Order No	l ₁ / (Order Code character)	13 (A)	16 (B)	20 (C)	22 (D)	25 (E)	28 (F)	30 (G)	32 (H)	35 (J)	40 (K)
10 / (4)	1.3	6.8	3 (2) 4 (3) 5 (4)		●	●	●	●	●	●	●	●	●	●
13 / (5)	1.9	8.8	3 (2) 5 (4) 8 (6)		●	●	●	●	●	●	●	●	●	●
16 / (6)	1.9	10.8	3 (2) 5 (4) 8 (6)				●	●	●	●	●	●	●	●
20 / (7)	1.9	13.6	3 (2) 5 (4) 10 (7)				●	●	●	●	●	●	●	●
22 / (8)	1.9	15	3 (2) 6 (5) 10 (7)				●	●	●	●	●	●	●	●
25 / (9)	1.9	17	3 (2) 6 (5) 10 (7)				●	●	●	●	●	●	●	●
32 / (10)	1.9	22	3 (2) 6 (5) 12 (8)				●	●	●	●	●	●	●	●
38 / (11)	1.9	27	3 (2) 8 (6) 12 (8)				●	●	●	●	●	●	●	●
40 / (12)	1.9	27	3 (2) 8 (6) 12 (8)				●	●	●	●	●	●	●	●
45 / (13)	2.4	35	3 (2) 8 (6) 12 (8)				●	●	●	●	●	●	●	●
50 / (14)	4	40	3 (2) 8 (6) 12 (8)				●	●	●	●	●	●	●	●
56 / (15)	4	45	3 (2) 8 (6) 12 (8)				●	●	●	●	●	●	●	●
63 / (16)	4	50	3 (2) 8 (6) 12 (8)				●	●	●	●	●	●	●	●
71 / (17)	4	56	3 (2) 8 (6) 12 (8)				●	●	●	●	●	●	●	●
76 / (18)	5.6	60	3 (2) 8 (6) 12 (8)				●	●	●	●	●	●	●	●
85 / (19)	5.6	66	3 (2) 8 (6) 12 (8)				●	●	●	●	●	●	●	●
90 / (20)	5.6	70	3 (2) 8 (6) 12 (8)				●	●	●	●	●	●	●	●
100 / (21)	5.6	78	3 (2) 8 (6) 12 (8)				●	●	●	●	●	●	●	●

Material:

HSS
Hardness 62 ± 2 HRC

Execution:

Diameter d₂ and end faces ground.
Special dimensions on request.

Note:

With kerf ≤ 0.04 mm, FIBRO rounds off sharp edges if the punch and piercing die bush are ordered together. This reduces the fitting time and the risk of an edge break during operation.

Ordering Code (example): with anti-rotation element

2625.10F8.1350.A3

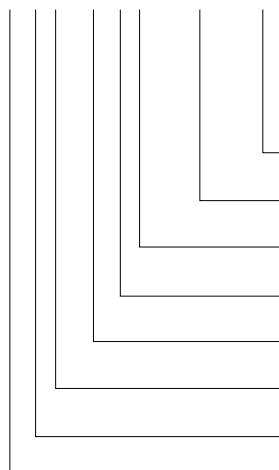

Anti-rotation element:
Pin ∅ 6 mm
Angle:
0°
Shape: square, Length P
P = 13,5 mm
Shape cutting length: l
12 mm
Length: l₁
28 mm
Diameter: d₂
32 mm
Type: without shoulder
Automotive Standard
Execution:
square
Matrix

Order No
= (3)
Order Code character
= (A)
= (1350)
Order No
= (8)
Order Code character
= (F)
Order No
= (10)
Order No
= (5)
Order No
= (2)
Order No
= (26)

MATRIX WITHOUT SHOULDER, AUTOMOTIVE STANDARD, ANTI-ROTATION ELEMENTS

Anti-rotation element 1 (1)

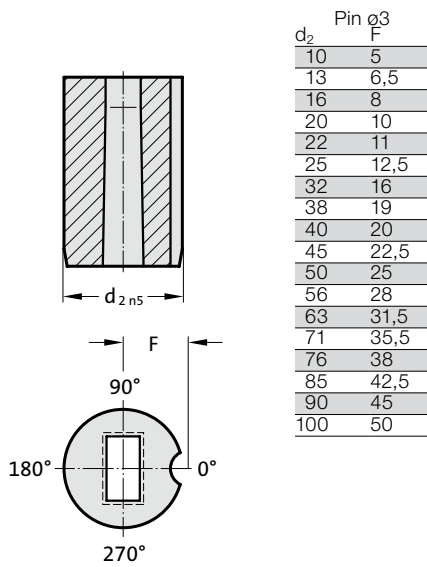

Anti-rotation element 2 (2)

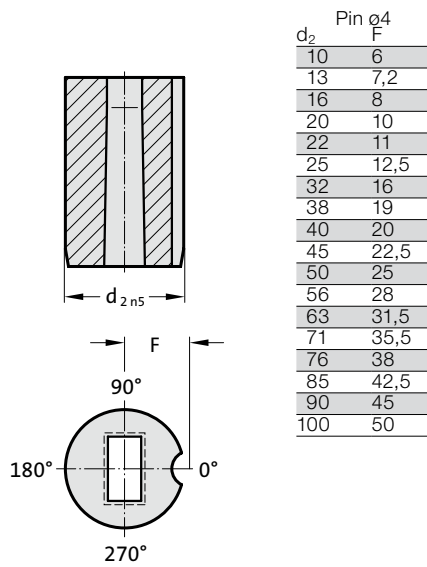

Anti-rotation element 3 (3)

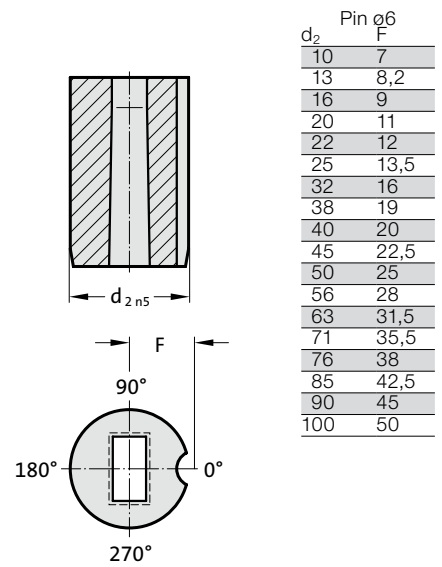

Anti-rotation element 4 (4)

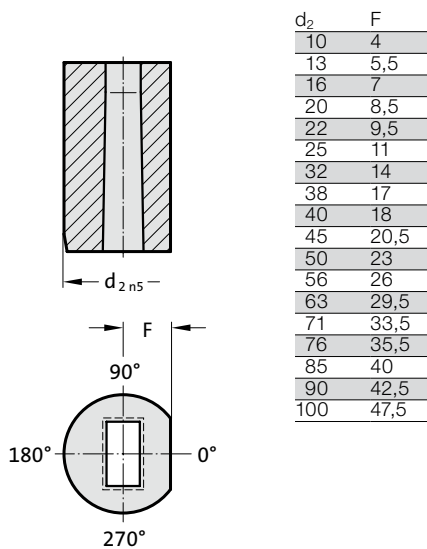

Anti-rotation element 5 (5)

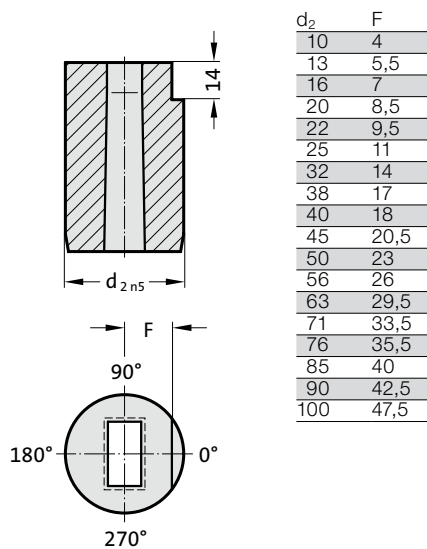

Anti-rotation element 6 (6)

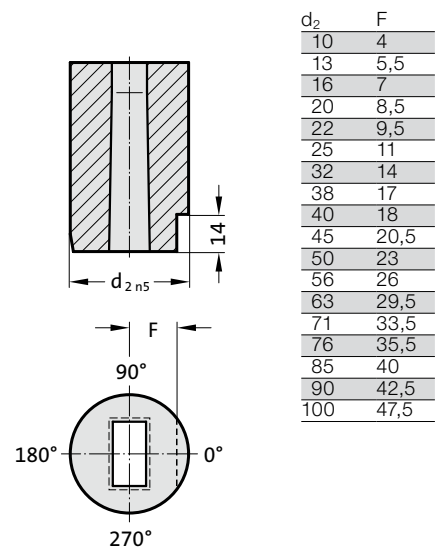

MATRIX WITHOUT SHOULDER, RECTANGULAR, AUTOMOTIVE STANDARD



2635.

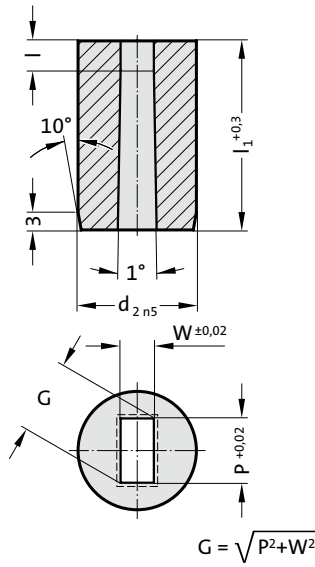

2635. Matrix without shoulder, rectangular, Automotive Standard

d ₂ / Order No	W _{min}	G _{max}	l / Order No	l ₁ / (Order Code character)	13 (A)	16 (B)	20 (C)	22 (D)	25 (E)	28 (F)	30 (G)	32 (H)	35 (J)	40 (K)
10 / (4)	1.3	6.8	3 (2) 4 (3) 5 (4)		●	●	●	●	●	●	●	●	●	
13 / (5)	1.9	8.8	3 (2) 5 (4) 8 (6)		●	●	●	●	●	●	●	●	●	
16 / (6)	1.9	10.8	3 (2) 5 (4) 8 (6)				●	●	●	●	●	●	●	
20 / (7)	1.9	13.6	3 (2) 5 (4) 10 (7)				●	●	●	●	●	●	●	
22 / (8)	1.9	15	3 (2) 6 (5) 10 (7)				●	●	●	●	●	●	●	
25 / (9)	1.9	17	3 (2) 6 (5) 10 (7)				●	●	●	●	●	●	●	
32 / (10)	1.9	22	3 (2) 6 (5) 12 (8)				●	●	●	●	●	●	●	
38 / (11)	1.9	27	3 (2) 8 (6) 12 (8)				●	●	●	●	●	●	●	●
40 / (12)	1.9	27	3 (2) 8 (6) 12 (8)					●	●	●	●	●	●	●
45 / (13)	2.4	35	3 (2) 8 (6) 12 (8)					●	●	●	●	●	●	●
50 / (14)	4	40	3 (2) 8 (6) 12 (8)					●	●	●	●	●	●	●
56 / (15)	4	45	3 (2) 8 (6) 12 (8)					●	●	●	●	●	●	●
63 / (16)	4	50	3 (2) 8 (6) 12 (8)					●	●	●	●	●	●	●
71 / (17)	4	56	3 (2) 8 (6) 12 (8)					●	●	●	●	●	●	●
76 / (18)	5.6	60	3 (2) 8 (6) 12 (8)						●	●	●	●	●	●
85 / (19)	5.6	66	3 (2) 8 (6) 12 (8)						●	●	●	●	●	●
90 / (20)	5.6	70	3 (2) 8 (6) 12 (8)						●	●	●	●	●	●
100 / (21)	5.6	78	3 (2) 8 (6) 12 (8)						●	●	●	●	●	●

Material:

HSS
Hardness 62 ± 2 HRC

Execution:

Diameter d₂ and end faces ground.
Special dimensions on request.

Note:

With kerf ≤ 0.04 mm, FIBRO rounds off sharp edges if the punch and piercing die bush are ordered together. This reduces the fitting time and the risk of an edge break during operation.

Ordering Code (example): with anti-rotation element

2635.10F8.1350.0650.A3

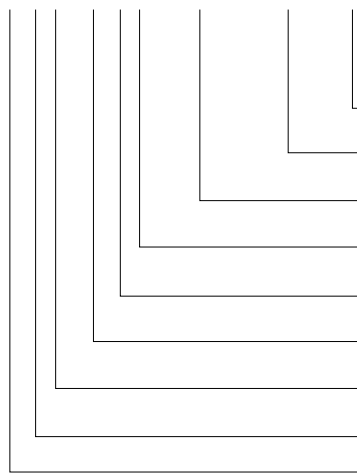

Anti-rotation element:

Pin ∅ 6 mm

Angle:

0°

Shape: rectangular, Width W

W = 6,5 mm

Shape: rectangular, Length P

P = 13,5 mm

Shape cutting length: l

12 mm

Length: l₁

28 mm

Diameter: d₂

32 mm

Type: without shoulder

Automotive Standard

Execution:

rectangular

Matrix

Order No

= (3)

Order Code character

= (A)

= (0650)

= (1350)

Order No

= (8)

Order Code character

= (F)

Order No

= (10)

Order No

= (5)

Order No

= (3)

= 26

MATRIX WITHOUT SHOULDER, AUTOMOTIVE STANDARD, ANTI-ROTATION ELEMENTS

Anti-rotation element 1 (1)

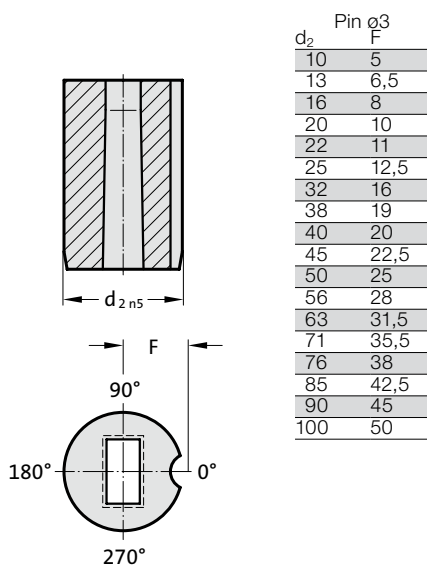

Anti-rotation element 2 (2)

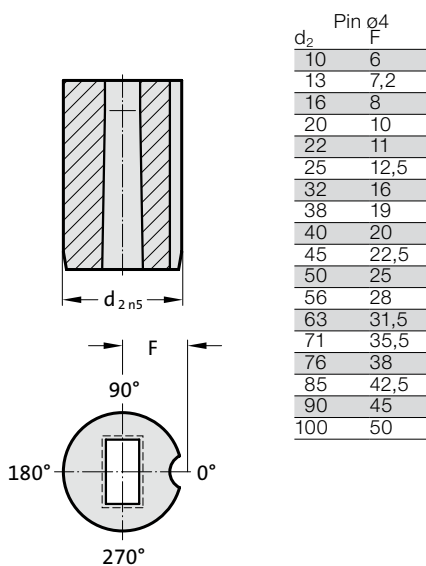

Anti-rotation element 3 (3)

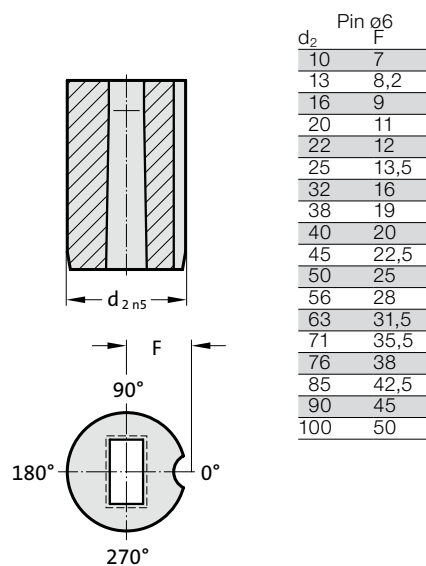

Anti-rotation element 4 (4)

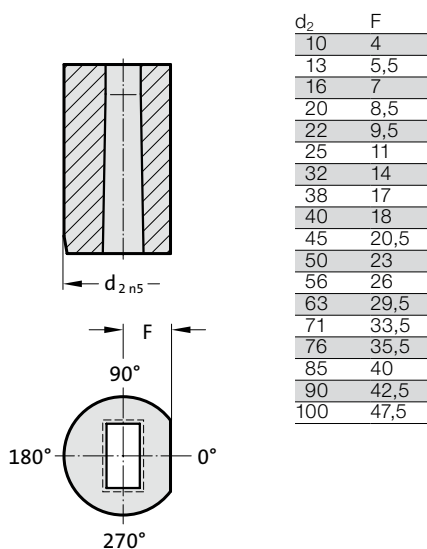

Anti-rotation element 5 (5)

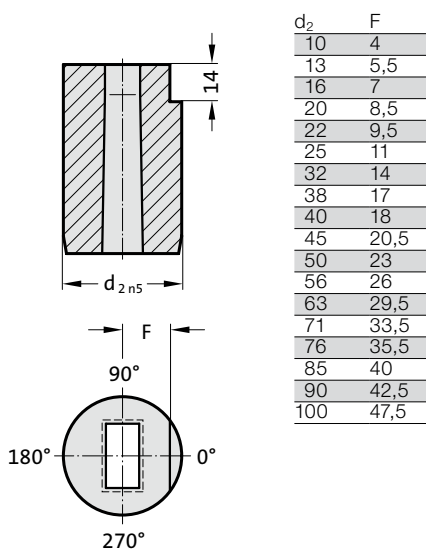

Anti-rotation element 6 (6)

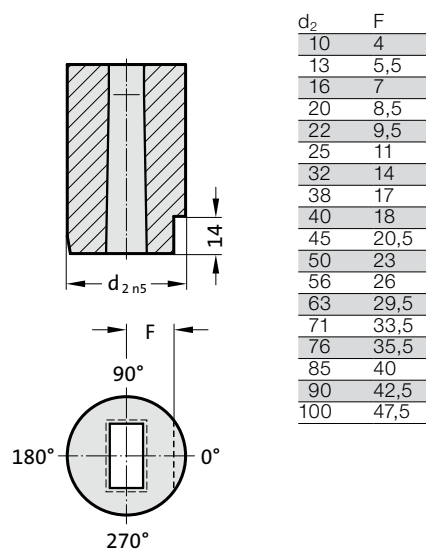

MATRIX WITHOUT SHOULDER, SLOT, AUTOMOTIVE STANDARD



2645.

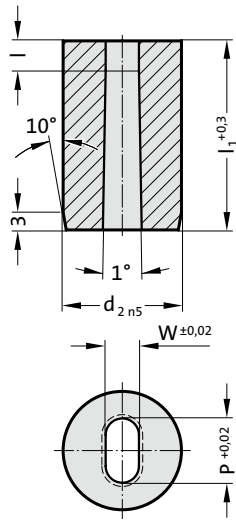

G = P

2645. Matrix without shoulder, slot, Automotive Standard

d ₂ / Order No	W _{min}	G _{max}	l / Order No	l ₁ / (Order Code character)	13 (A)	16 (B)	20 (C)	22 (D)	25 (E)	28 (F)	30 (G)	32 (H)	35 (J)	40 (K)
10 / (4)	1.3	6.8	3 (2) 4 (3) 5 (4)		●	●	●	●	●	●	●	●	●	●
13 / (5)	1.9	8.8	3 (2) 5 (4) 8 (6)		●	●	●	●	●	●	●	●	●	●
16 / (6)	1.9	10.8	3 (2) 5 (4) 8 (6)				●	●	●	●	●	●	●	●
20 / (7)	1.9	13.6	3 (2) 5 (4) 10 (7)				●	●	●	●	●	●	●	●
22 / (8)	1.9	15	3 (2) 6 (5) 10 (7)				●	●	●	●	●	●	●	●
25 / (9)	1.9	17	3 (2) 6 (5) 10 (7)				●	●	●	●	●	●	●	●
32 / (10)	1.9	22	3 (2) 6 (5) 12 (8)				●	●	●	●	●	●	●	●
38 / (11)	1.9	27	3 (2) 8 (6) 12 (8)				●	●	●	●	●	●	●	●
40 / (12)	1.9	27	3 (2) 8 (6) 12 (8)				●	●	●	●	●	●	●	●
45 / (13)	2.4	35	3 (2) 8 (6) 12 (8)				●	●	●	●	●	●	●	●
50 / (14)	4	40	3 (2) 8 (6) 12 (8)				●	●	●	●	●	●	●	●
56 / (15)	4	45	3 (2) 8 (6) 12 (8)				●	●	●	●	●	●	●	●
63 / (16)	4	50	3 (2) 8 (6) 12 (8)				●	●	●	●	●	●	●	●
71 / (17)	4	56	3 (2) 8 (6) 12 (8)				●	●	●	●	●	●	●	●
76 / (18)	5.6	60	3 (2) 8 (6) 12 (8)				●	●	●	●	●	●	●	●
85 / (19)	5.6	66	3 (2) 8 (6) 12 (8)				●	●	●	●	●	●	●	●
90 / (20)	5.6	70	3 (2) 8 (6) 12 (8)				●	●	●	●	●	●	●	●
100 / (21)	5.6	78	3 (2) 8 (6) 12 (8)				●	●	●	●	●	●	●	●

Material:

HSS

Hardness 62 ± 2 HRC

Execution:

Diameter d₂ and end faces ground.

Special dimensions on request.

Ordering Code (example): with anti-rotation element

2645.10F8.1350.0650.A3

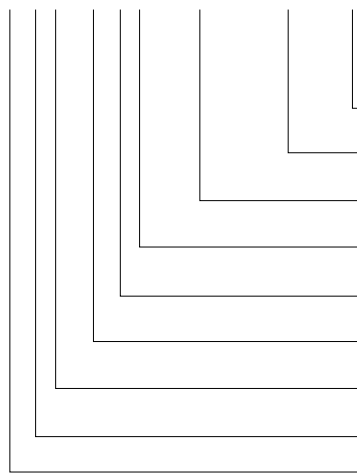

Anti-rotation element:

Pin ∅ 6 mm

Angle:

0°

Shape: slot, Width W

W = 6,5 mm

Shape: slot, Length P

P = 13,5 mm

Shape cutting length: l

12 mm

Length: l₁

28 mm

Diameter: d₂

32 mm

Type: without shoulder

Automotive Standard

Execution:

slot

Matrix

Order No

= (3)

Order Code character

= (A)

= (0650)

= (1350)

Order No

= (8)

Order Code character

= (F)

Order No

= (10)

Order No

= (5)

Order No

= (4)

= 26

MATRIX WITHOUT SHOULDER, AUTOMOTIVE STANDARD, ANTI-ROTATION ELEMENTS

Anti-rotation element 1 (1)

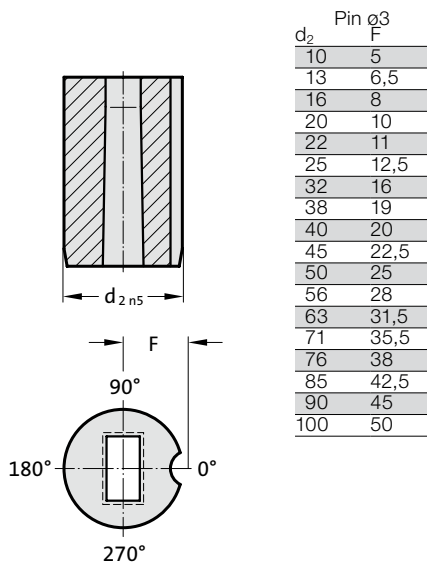

Anti-rotation element 2 (2)

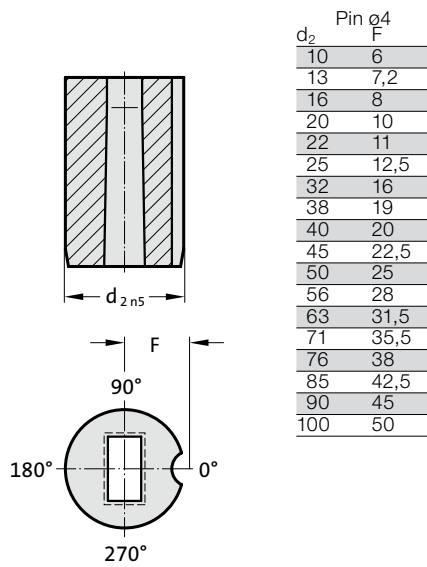

Anti-rotation element 3 (3)

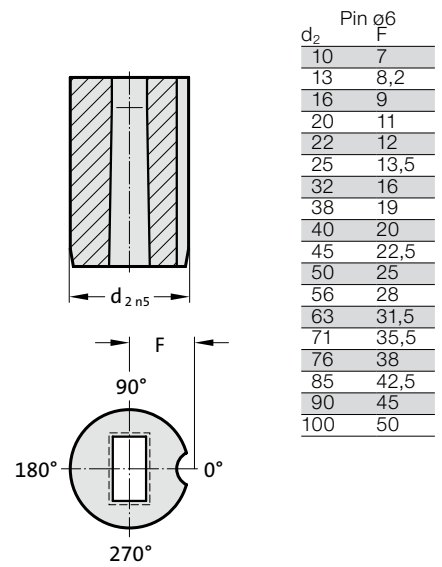

Anti-rotation element 4 (4)

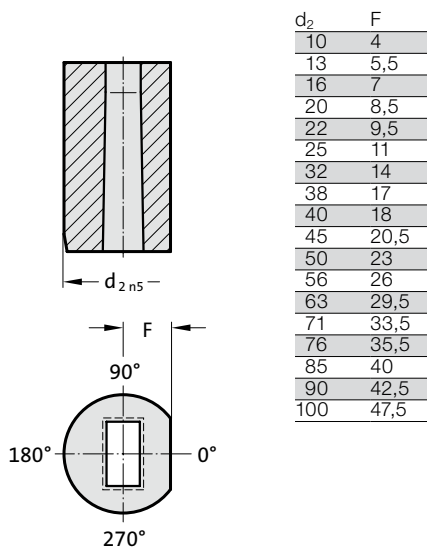

Anti-rotation element 5 (5)

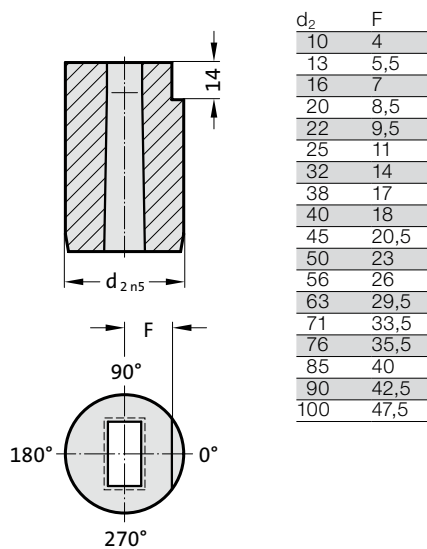

Anti-rotation element 6 (6)

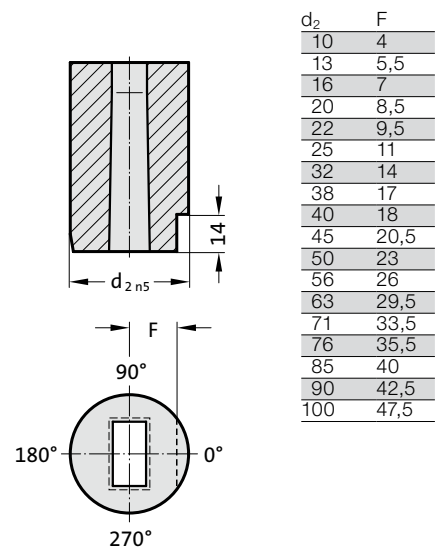

MATRIX WITHOUT SHOULDER, RECTANGLE WITH RADIUSED CORNERS, AUTOMOTIVE STANDARD



2655.

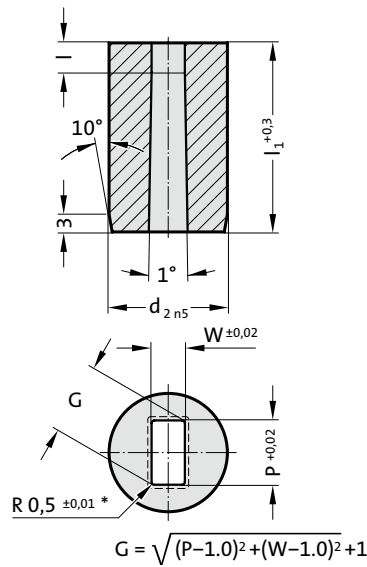

2655. Matrix without shoulder, rectangle with radiused corners, Automotive Standard

d ₂ / Order No	W _{min}	G _{max}	l / Order No	l ₁ / (Order Code character)	13 (A)	16 (B)	20 (C)	22 (D)	25 (E)	28 (F)	30 (G)	32 (H)	35 (J)	40 (K)
10 / (4)	1.3	6.8	3 (2) 4 (3) 5 (4)		●	●	●	●	●	●	●	●	●	●
13 / (5)	1.9	8.8	3 (2) 5 (4) 8 (6)		●	●	●	●	●	●	●	●	●	●
16 / (6)	1.9	10.8	3 (2) 5 (4) 8 (6)				●	●	●	●	●	●	●	●
20 / (7)	1.9	13.6	3 (2) 5 (4) 10 (7)				●	●	●	●	●	●	●	●
22 / (8)	1.9	15	3 (2) 6 (5) 10 (7)				●	●	●	●	●	●	●	●
25 / (9)	1.9	17	3 (2) 6 (5) 10 (7)				●	●	●	●	●	●	●	●
32 / (10)	1.9	22	3 (2) 6 (5) 12 (8)				●	●	●	●	●	●	●	●
38 / (11)	1.9	27	3 (2) 8 (6) 12 (8)				●	●	●	●	●	●	●	●
40 / (12)	1.9	27	3 (2) 8 (6) 12 (8)					●	●	●	●	●	●	●
45 / (13)	2.4	35	3 (2) 8 (6) 12 (8)					●	●	●	●	●	●	●
50 / (14)	4	40	3 (2) 8 (6) 12 (8)					●	●	●	●	●	●	●
56 / (15)	4	45	3 (2) 8 (6) 12 (8)					●	●	●	●	●	●	●
63 / (16)	4	50	3 (2) 8 (6) 12 (8)					●	●	●	●	●	●	●
71 / (17)	4	56	3 (2) 8 (6) 12 (8)					●	●	●	●	●	●	●
76 / (18)	5.6	60	3 (2) 8 (6) 12 (8)						●	●	●	●	●	●
85 / (19)	5.6	66	3 (2) 8 (6) 12 (8)						●	●	●	●	●	●
90 / (20)	5.6	70	3 (2) 8 (6) 12 (8)						●	●	●	●	●	●
100 / (21)	5.6	78	3 (2) 8 (6) 12 (8)						●	●	●	●	●	●

Material:

HSS
Hardness 62 ± 2 HRC

Execution:

Diameter d₂ and end faces ground.
Special dimensions on request.

* For other radius options, see standardised special shapes.

Ordering Code (example): with anti-rotation element

2655.10F8.1350.0650.A3

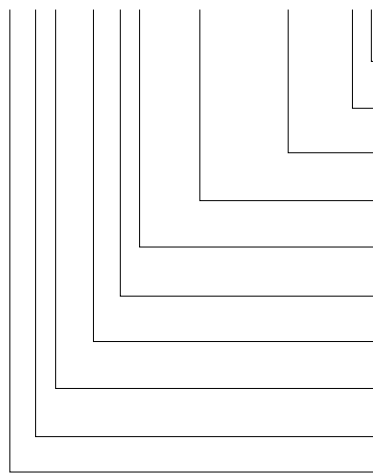

Anti-rotation element: Order No = (3)
Pin ∅ 6 mm

Angle: Order Code character = (A)
0°

Shape: rectangle with radiused corners, Width W
W = 6,5 mm
Order No = (0650)

Shape: rectangle with radiused corners, Length P
P = 13,5 mm
Order No = (1350)

Shape cutting length: l
12 mm
Order No = (8)

Length: l₁
28 mm
Order Code character = (F)

Diameter: d₂
32 mm
Order No = (10)

Type: without shoulder
Automotive Standard
Order No = (5)

Execution: Order No = (5)
rectangle with radiused corners

Matrixes
= 26

MATRIX WITHOUT SHOULDER, AUTOMOTIVE STANDARD, ANTI-ROTATION ELEMENTS

Anti-rotation element 1 (1)

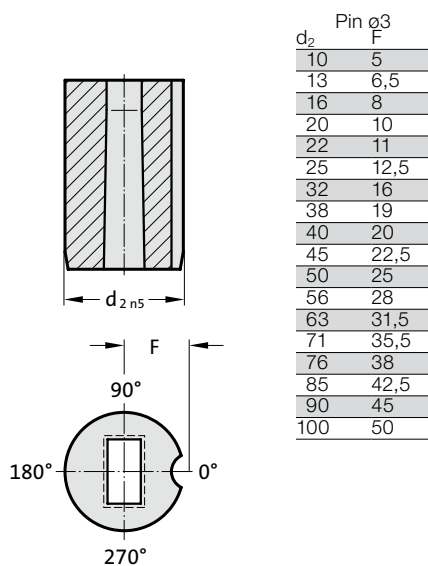

Anti-rotation element 2 (2)

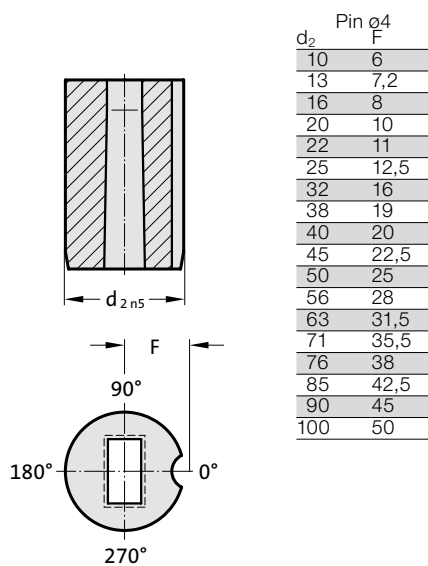

Anti-rotation element 3 (3)

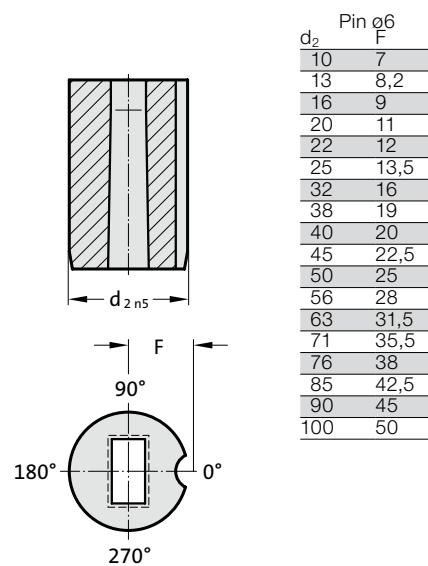

Anti-rotation element 4 (4)

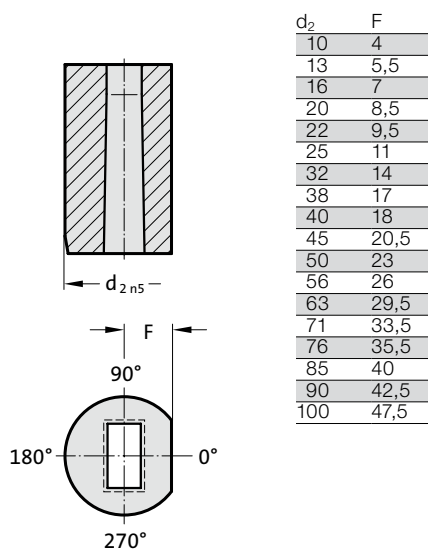

Anti-rotation element 5 (5)

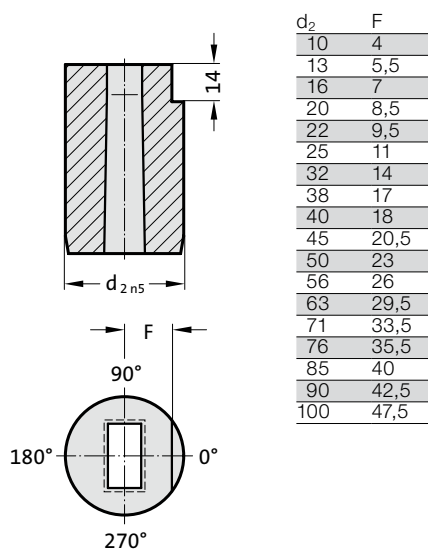

Anti-rotation element 6 (6)

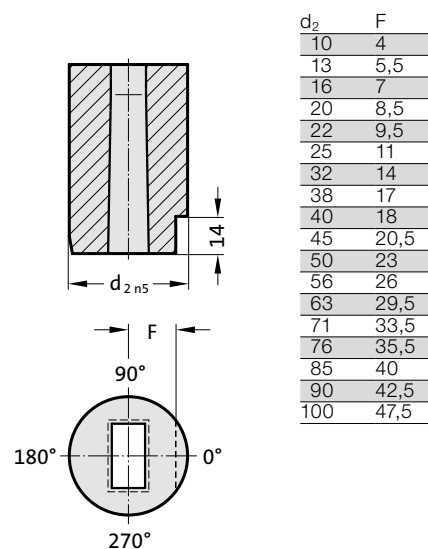

GUIDE BUSH FOR PUNCH, DIN 9845 SHAPE C



262.

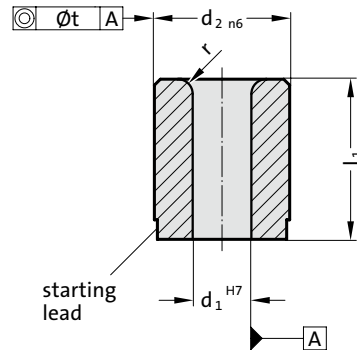

262. Guide bush for punch, DIN 9845 Shape C

d_1	Gradation	d_2	t	l_1	r
0,5 - 1	0,1	5	0,01	9	1
1,1 - 2	0,1	6	0,01	12	1
2,1 - 3	0,1	7	0,01	12	1
3,1 - 4	0,1	8	0,01	12	1
4,1 - 5	0,1	10	0,01	16	1
5,1 - 6	0,1	12	0,02	16	1,5
6,1 - 8	0,1	15	0,02	20	1,5
8,1 - 10	0,1	18	0,02	20	2
10,1 - 12	0,1	22	0,02	28	2
12,1 - 15	0,1	26	0,02	28	2
15,1 - 18	0,5	30	0,02	36	2

Material:

Case hardened steel
Hardness 740 ± 40 HV 10

Execution:

Diameters d_1 , d_2 and starting lead ground.

Ordering Code (example):

Guide bush for punch, DIN 9845 Shape C	=	262.1.
Diameter of conduit d_1	5.1 mm =	0510.
Length l_1	16 mm =	016
Order No	=	262.1. 0510. 016

GUIDE BUSH FOR PUNCH, ISO 8978

2621.

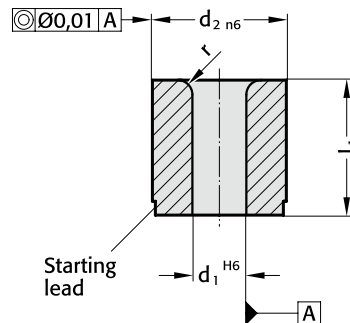

Material:

WS

Hardness 60 ± 2 HRC

Description of FIBRO materials for tool and die components see at the beginning of Chapter E.

Execution:

Diameters d_1 , d_2 and starting lead ground.

2621. Guide bush for punch, ISO 8978

		Gradation			
d_1	d_1	d_2	l_1	r	
1 - 2,4	0.1	5	8	1	
1,6 - 3	0.1	6	12.5	1	
2 - 3,5	0.1	8	12.5	1.5	
3 - 5	0.1	10	16	2	
4 - 7,2	0.1	13	16	2	
6 - 8,8	0.1	16	20	2	
7,5 - 11,3	0.1	20	20	2.5	
11 - 16,6	0.1	25	25	2.5	
15 - 20	0.5	32	25	4	
18 - 27	0.5	40	32	4	
26 - 36	0.5	50	40	4	

Ordering Code (example):

Guide bush for punch, ISO 8978	=	2621.1.
Diameter of conduit d_1	6 mm =	0600.
Outer diameter d_2	16 mm =	1600
Order No	=	2621.1. 0600. 1600

MATRIX WITHOUT COLLAR, DIN 9845 SHAPE A



260.

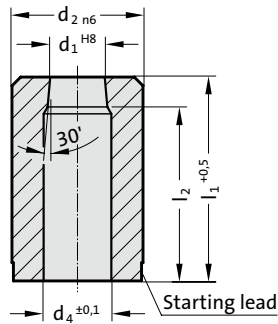

260. Matrix without collar, DIN 9845 Shape A

Gradation		d_2	l_1	20	28
d_1	d_1				
0,5 - 1	0.1	5	l_2	18	
1,1 - 2	0.1	6		17	25
2,1 - 3	0.1	7		17	25
3,1 - 4	0.1	8		17	25
4,1 - 5	0.1	10		16	24
5,1 - 6	0.1	12		16	24
6,1 - 8	0.1	15		16	24
8,1 - 10	0.1	18		16	24
10,1 - 12	0.1	22		15	23
12,1 - 15	0.1	26		15	23
15,1 - 18	0.1	30			

Material:

HSS

Order No 260.3.

Hardness 62 ± 2 HRC

Description of FIBRO materials for tool and die components see at the beginning of Chapter E.

Execution:

Diameters d_1 , d_2 and face surfaces ground.

d_4 : For $d_1 \leq 2$ mm, $d_4 = d_1 + 0,3$

For $d_1 = 2,1$ mm to 4,0 mm, $d_4 = d_1 + 0,5$

For $d_1 = 4,1$ mm to 8,0 mm, $d_4 = d_1 + 0,7$

For $d_1 \geq 8,1$ mm, $d_4 = d_1 + 1$

Other diameters on request.

Ordering Code (example):

Matrix without collar, DIN 9845 Shape A = 260.3.

Cutting diameter d_1 5.1 mm = 0510.

Length l_1 20 mm = 020

Order No = 260.3. 0510. 020

MATRIX WITH COLLAR, DIN 9845 SHAPE B

261.

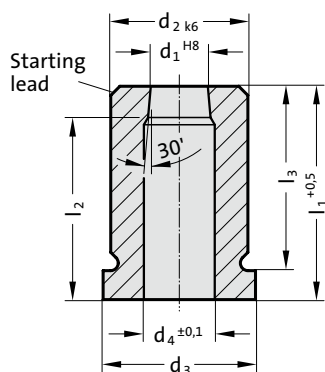

Material:

HSS

Order No 261.3.

Hardness 62 ± 2 HRC

 Description of FIBRO materials for tool and die components see at the beginning of Chapter E.

Execution:

Diameters d_1 , d_2 and face surfaces ground.

d_4 : For $d_1 \leq 2$ mm, $d_4 = d_1 + 0,3$

For $d_1 = 2,1$ mm to 4,0 mm, $d_4 = d_1 + 0,5$

For $d_1 = 4,1$ mm to 8,0 mm, $d_4 = d_1 + 0,7$

For $d_1 \geq 8,1$ mm, $d_4 = d_1 + 1$

Other diameters on request.

261. Matrix with collar, DIN 9845 Shape B

d_1	Gradation								
	d_1	d_2	d_3	l_1	20	28	l_1	20	28
0,5 - 1	0.1	5	7	l_2	18		l_3	16	
1,1 - 2	0.1	6	8		17	25		16	24
2,1 - 3	0.1	7	9		17	25		16	24
3,1 - 4	0.1	8	10		17	25		16	24
4,1 - 5	0.1	10	12		16	24		16	24
5,1 - 6	0.1	12	14		16	24		16	24
6,1 - 8	0.1	15	17		16	24		16	24
8,1 - 10	0.1	18	20		16	24		16	24
10,1 - 12	0.1	22	24		15	23		16	24
12,1 - 15	0.1	26	28		15	23		16	24
15,1 - 18	0.1	30	32			23			24

Ordering Code (example):

Matrix with collar, DIN 9845 Shape B = 261.3.

Cutting diameter d_1 5.1 mm = 0510.

Length l_1 20 mm = 020

Order No = 261.3.0510.020

MATRIX WITHOUT COLLAR, CYLINDRICAL



2602.

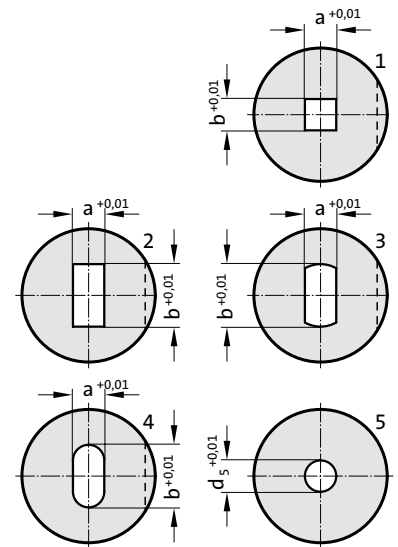
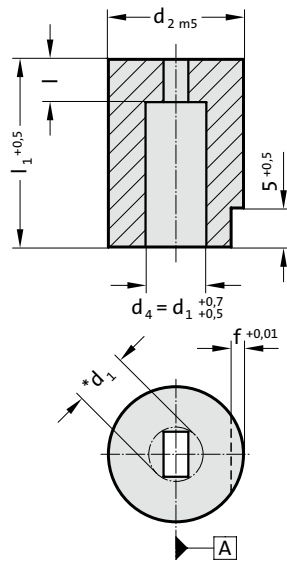

2602. Matrix without collar, cylindrical

d_1, d_5	d_2	l	f	l_1	16	19	22	25	28	32
1,8 - 3,2	8	3	1		●	●	●	●	●	●
2 - 5	10	3	1		●	●	●	●	●	●
3 - 7	13	3	1.5		●	●	●	●	●	●
5 - 8	16	5	1.5		●	●	●	●	●	●
7 - 11	20	5	1.5		●	●	●	●	●	●
11 - 16	25	5	2.5		●	●	●	●	●	●
16 - 19	32	7	2.5		●	●	●	●	●	●
19 - 28	40	7	2.5		●	●	●	●	●	●

Material:

HSS

Order No. 2602.3.

Hardness 64 ± 2 HRC

Execution:

Diameter d_2 and end faces ground.

Key flats parallel with reference axis "A" unless otherwise specified.

* d_1 = size over corners

With starting holes for wire-EDM as per 2601.

Ordering Code (example):

Matrix without collar, cylindrical	=	2602.3.
Mount diameter d_2	20 mm =	020.
Length l_1	16 mm =	016.
Cutting form Shape	square =	1.
Cutting form width a	320 =	0320.
Cutting form length b	320 =	0320
Order No	=	2602.3. 020. 016. 1. 0320. 0320

MATRIX WITH COLLAR, CYLINDRICAL

2612.

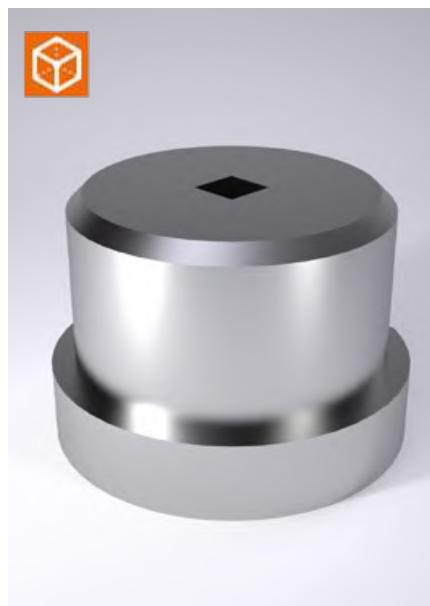
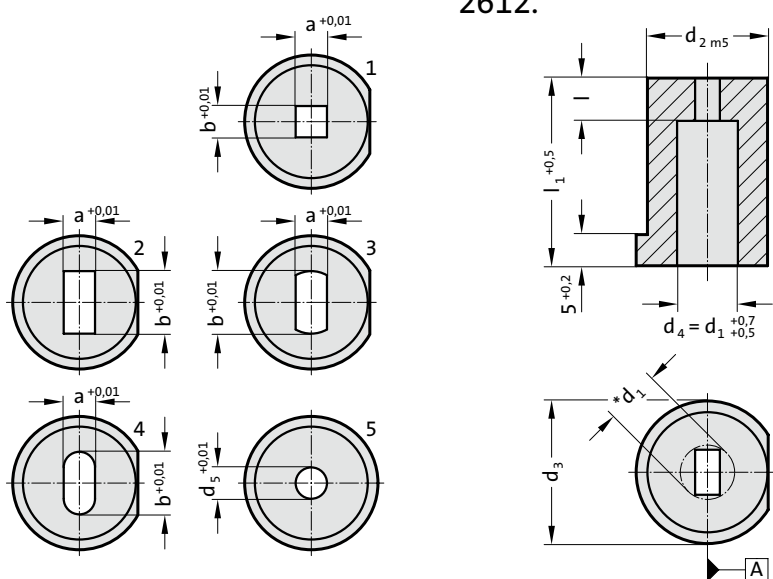

Material:

HSS

Order No. 2612.3.

Hardness 64 ± 2 HRC

Execution:

Diameter d_2 and end faces ground.

Key flats parallel with reference axis "A" unless otherwise specified.

* d_1 = size over corners

With starting holes for wire-EDM as per 2611.

2612. Matrix with collar, cylindrical

d_1, d_5	d_2	d_3	l	l_1	16	19	22	25	28	32
1,8 - 3,2	8	11	3		●	●	●	●	●	●
2 - 5	10	13	3		●	●	●	●	●	●
3 - 7	13	16	3		●	●	●	●	●	●
5 - 8	16	19	5		●	●	●	●	●	●
7 - 11	20	23	5		●	●	●	●	●	●
11 - 16	25	28	5		●	●	●	●	●	●
16 - 19	32	35	7		●	●	●	●	●	●
19 - 28	40	43	7		●	●	●	●	●	●

Ordering Code (example):

Matrix with collar, cylindrical	=	2612.3.
Mount diameter d_2	20 mm =	020.
Length l_1	16 mm =	016.
Cutting form Shape	square =	1.
Cutting form width a	320 =	0320.
Cutting form length b	320 =	0320
Order No	=	2612.3. 020. 016. 1. 0320. 0320

MATRIX WITHOUT COLLAR, CONICAL



2601.

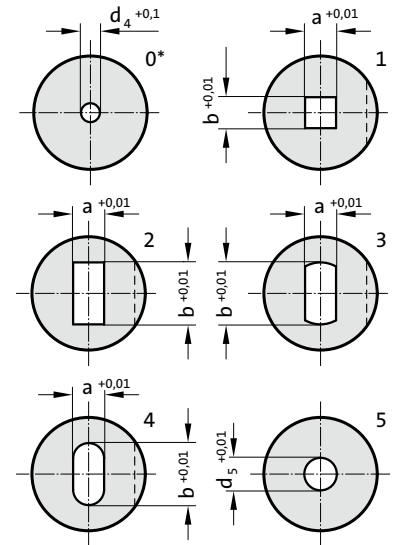
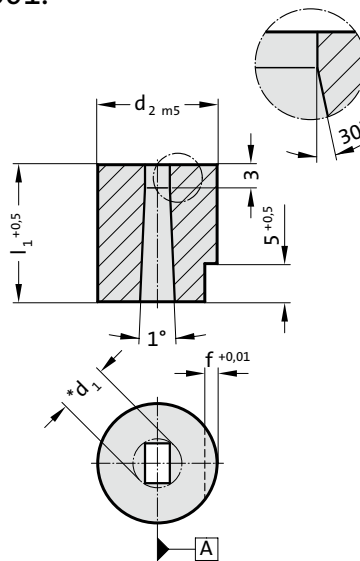

2601. Matrix without collar, conical

d_1, d_5	d_2	d_4	f	l_1	16	19	22	25	28	32
1,6 - 3,2	8	1	1		●	●	●	●	●	●
2 - 5	10	1	1		●	●	●	●	●	●
3 - 7	13	1.5	1.5		●	●	●	●	●	●
5 - 8	16	1.5	1.5		●	●	●	●	●	●
7 - 11	20	1.5	1.5		●	●	●	●	●	●
11 - 16	25	2.5	2.5		●	●	●	●	●	●
16 - 19	32	2.5	2.5		●	●	●	●	●	●
19 - 28	40	2.5	2.5		●	●	●	●	●	●

Material:

HSS
Order No. 2601.3.
Hardness 64 ± 2 HRC

Execution:

Diameter d_2 and end faces ground.
Key flats parallel with reference axis "A" unless otherwise specified.
* d_1 = size over corners
*0 = Execution only with starting hole for wire-EDM

Ordering Code (example):

Matrix without collar, conical	=	2601.3.
Mount diameter d_2	20 mm =	020.
Length l_1	16 mm =	016.
Cutting form Shape	square =	1.
Cutting form width a	320 =	0320.
Cutting form length b	320 =	0320
Order No	=	2601.3. 020. 016. 1. 0320. 0320

MATRIX WITH COLLAR, CONICAL

2611.

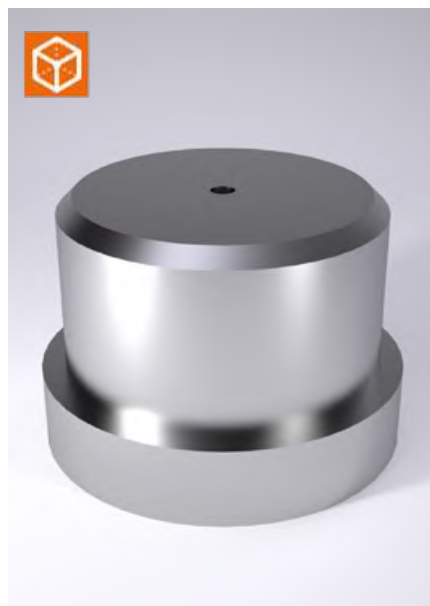
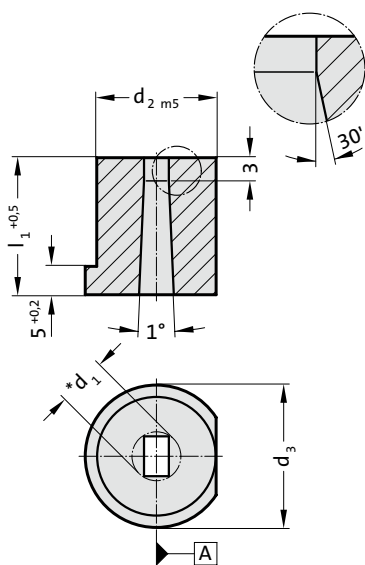
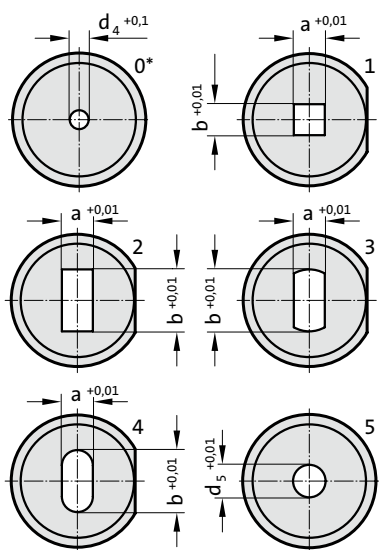

Material:

HSS

Order No. 2611.3.

Hardness 64 ± 2 HRC

Execution:

Diameter d_2 and end faces ground.

Key flats parallel with reference axis "A" unless otherwise specified.

* d_1 = size over corners

*0 = Execution only with starting hole for wire-EDM

2611. Matrix with collar, conical

d_1, d_5	d_2	d_3	d_4	l_1	16	19	22	25	28	32
1,6 - 3,2	8	11	1		●	●	●	●	●	●
2 - 5	10	13	1		●	●	●	●	●	●
3 - 7	13	16	1,5		●	●	●	●	●	●
5 - 8	16	19	1,5		●	●	●	●	●	●
7 - 11	20	23	1,5		●	●	●	●	●	●
11 - 16	25	28	2,5		●	●	●	●	●	●
16 - 19	32	35	2,5		●	●	●	●	●	●
19 - 28	40	43	2,5		●	●	●	●	●	●

Ordering Code (example):

Matrix with collar, conical = 2611.3.

Mount diameter d_2 20 mm = 020.

Length l_1 16 mm = 016.

Cutting form Shape square = 1.

Cutting form width a 320 = 0320.

Cutting form length b 320 = 0320.

Order No = 2611.3.020.016.1.0320.0320

STANDARDISED SPECIAL SHAPES



PUNCH/CUTTING BUSHINGS, STANDARDISED SPECIAL FORMS - EXAMPLE ORDERS

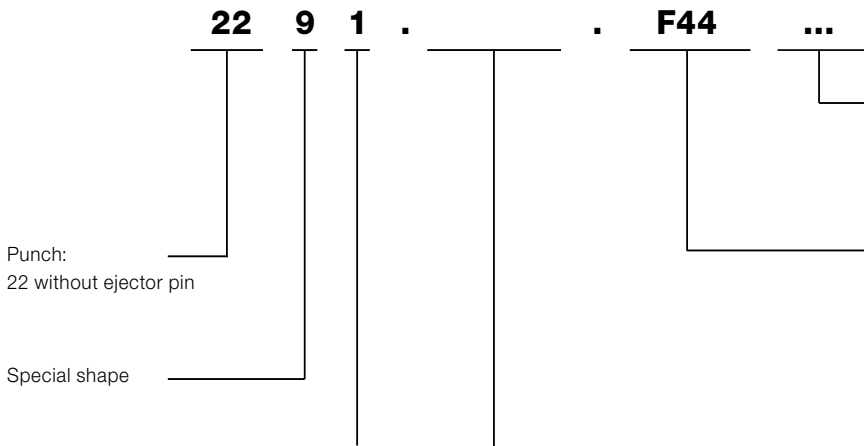

Attention!
All the parameters must be given for special shapes!

Special shape F 44

Punch:
22 without ejector pin

Special shape

Type:	Order No
ISO	= 1
ball-lock, light duty	= 2
ball-lock, heavy duty	= 3
ball-lock, larger cutting edge,= 4 light duty	
ball-lock, larger cutting edge,= 5 heavy duty	

You will find diameters and lengths on the pages of punches you have selected.

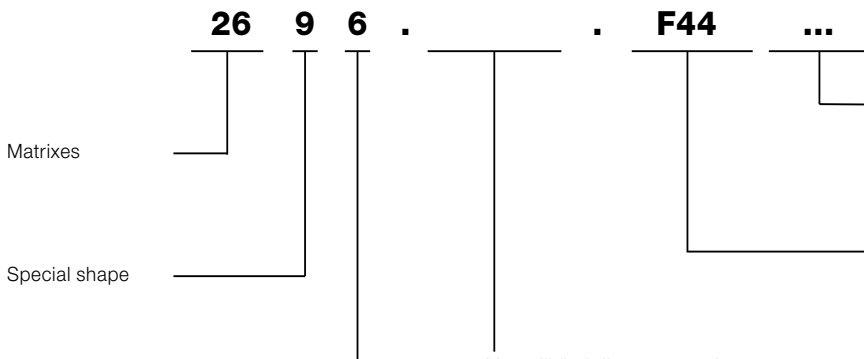
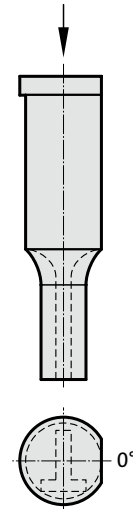

Attention!
All the parameters must be given for special shapes!

Special shape F 44

Matrixes

Special shape

Type:	Order No
automotive standard	= 5
without shoulder ISO 8977	= 6
with shoulder ISO 8977	= 7

You will find diameters and lengths on the pages of cutting bushes you have selected.

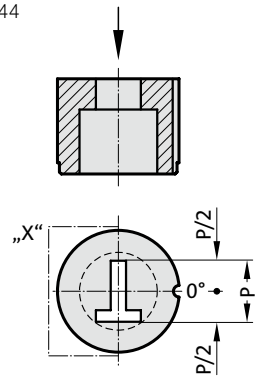

Cutting gap (a)

Roundings with the corresponding sharp corners reduce the cutting gap per side (a). If the cutting gap is 0.04 mm (a) or less, FIBRO will round the sharp edges if the cutting punch and the matrixes are ordered together. This reduces the installation time and the risk of an edge breaking during operation.

Note:

- (1) and (2) - roundings and sharp edges
- (1) rounding on the cutting punch of max. R0.2, corresponds to a sharp edge on the matrix
- (2) rounding on the cutting matrix of max. R0.2, corresponds to a sharp edge on the punch

View „X“

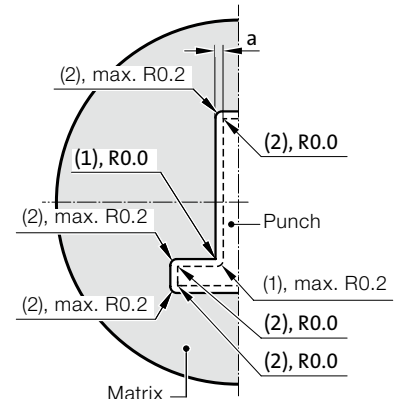

STANDARDISED SPECIAL SHAPES

90°

Round, flattened

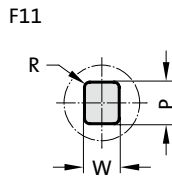
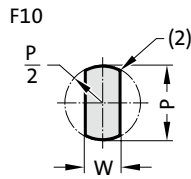

Key-hole shapes

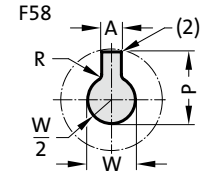
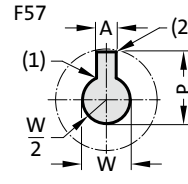
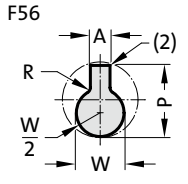
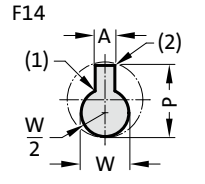
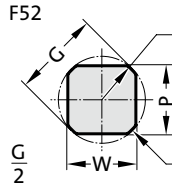
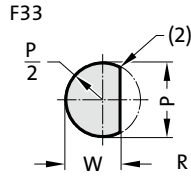
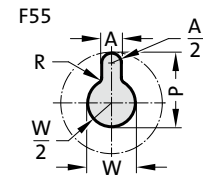
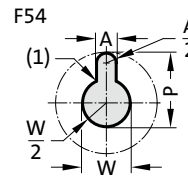
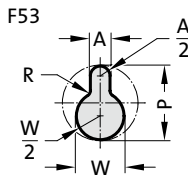
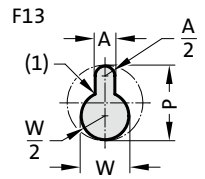

Various

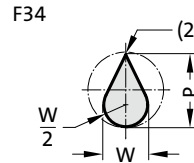
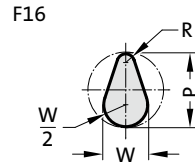
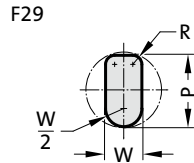
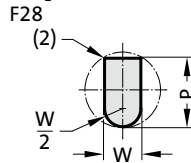
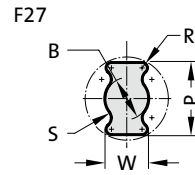
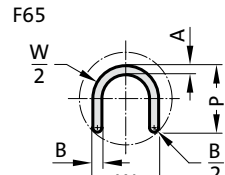
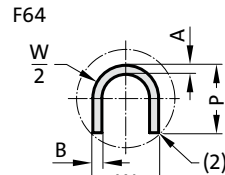
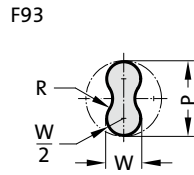
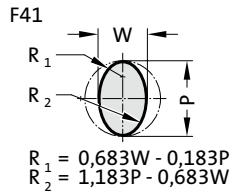

180° Triangles, trapezes

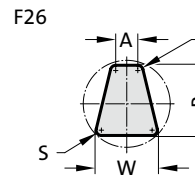
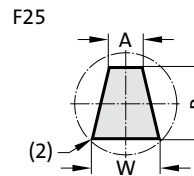
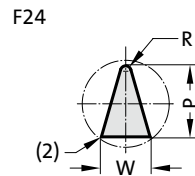
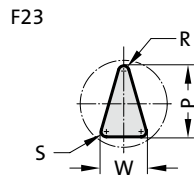
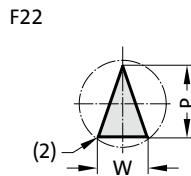

Key-hole

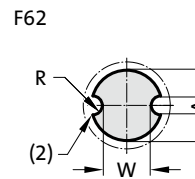
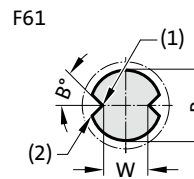
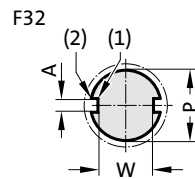
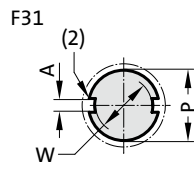
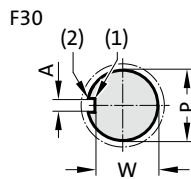

Polygons

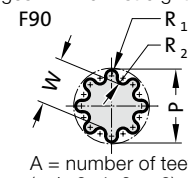
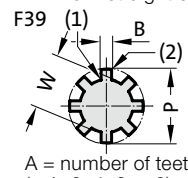
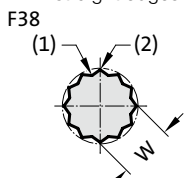
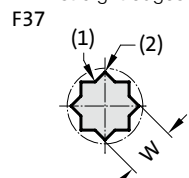
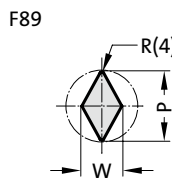
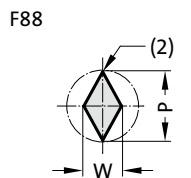
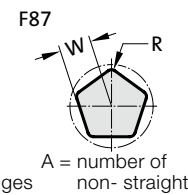
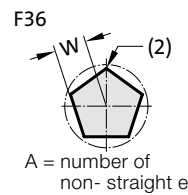
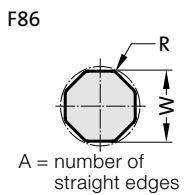
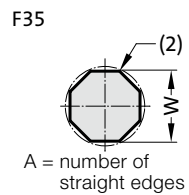
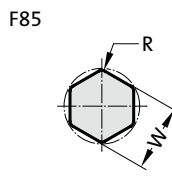
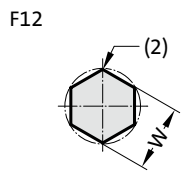

270°

0°

PUNCH/CUTTING BUSHINGS, STANDARDISED SPECIAL FORMS - EXAMPLE ORDERS

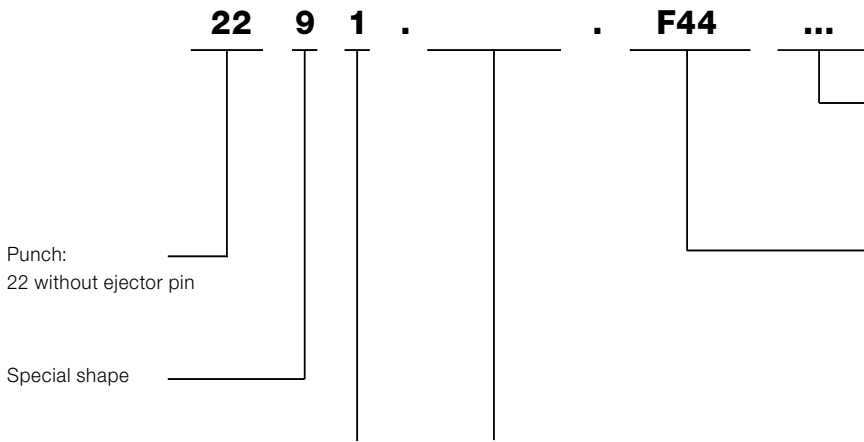

Attention!
All the parameters must be given for special shapes!

Punch:
22 without ejector pin

Special shape

Special shape F 44

Type:	Order No
ISO	= 1
ball-lock, light duty	= 2
ball-lock, heavy duty	= 3
ball-lock, larger cutting edge,= 4 light duty	
ball-lock, larger cutting edge,= 5 heavy duty	

You will find diameters and lengths on the pages of punches you have selected.

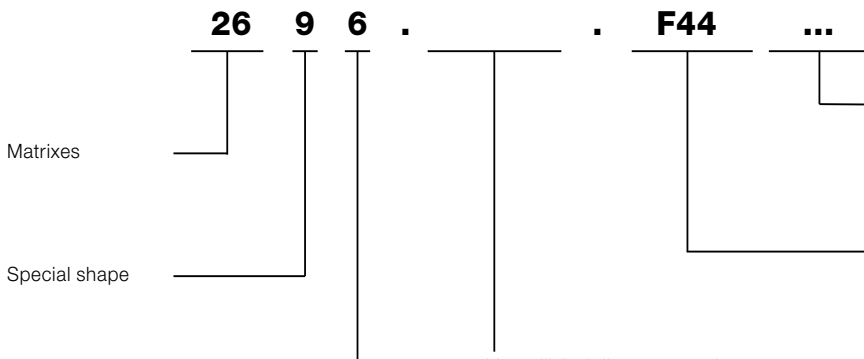
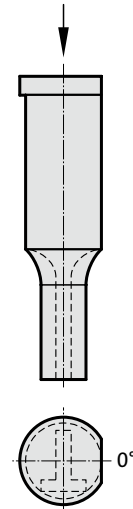

Attention!
All the parameters must be given for special shapes!

Matrixes

Special shape

Special shape F 44

Type:	Order No
automotive standard	= 5
without shoulder ISO 8977	= 6
with shoulder ISO 8977	= 7

You will find diameters and lengths on the pages of cutting bushes you have selected.

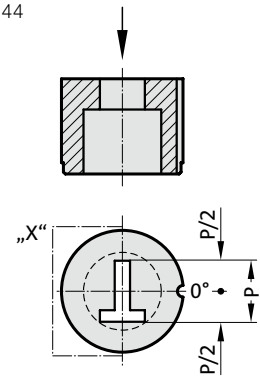

Cutting gap (a)

Roundings with the corresponding sharp corners reduce the cutting gap per side (a). If the cutting gap is 0.04 mm (a) or less, FIBRO will round the sharp edges if the cutting punch and the matrixes are ordered together. This reduces the installation time and the risk of an edge breaking during operation.

Note:

- (1) and (2) - roundings and sharp edges
- (1) rounding on the cutting punch of max. R0.2, corresponds to a sharp edge on the matrix
- (2) rounding on the cutting matrix of max. R0.2, corresponds to a sharp edge on the punch

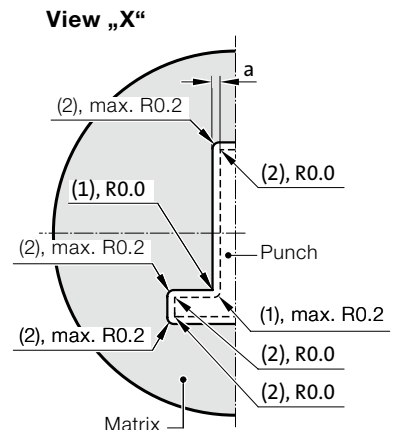

STANDARDISED SPECIAL SHAPES

90°

Multi key-hole shapes

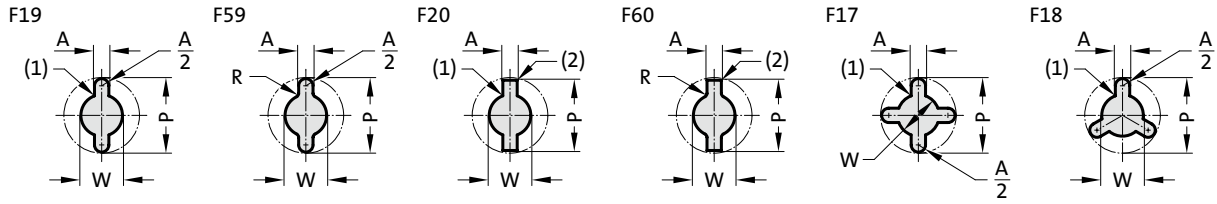

Double T-shapes

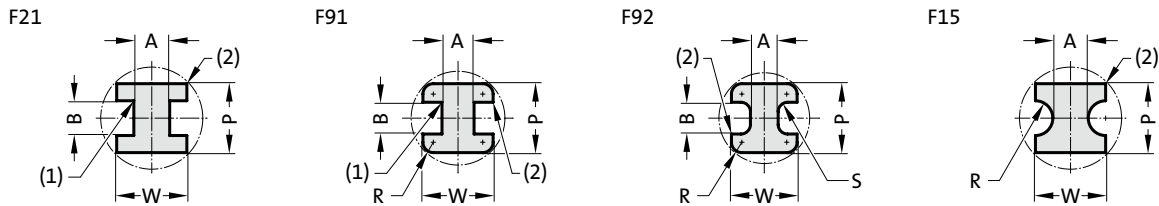

Simple T-shapes

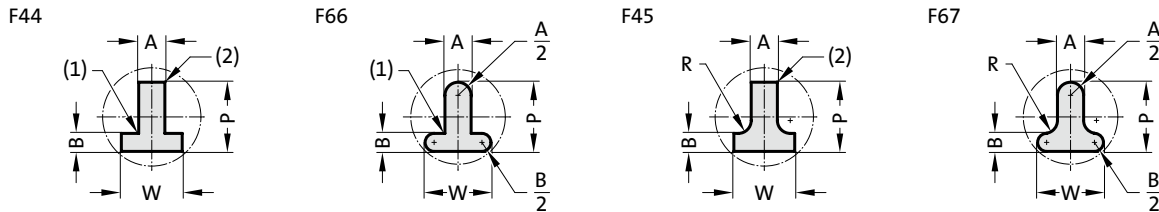

L-shapes

180°

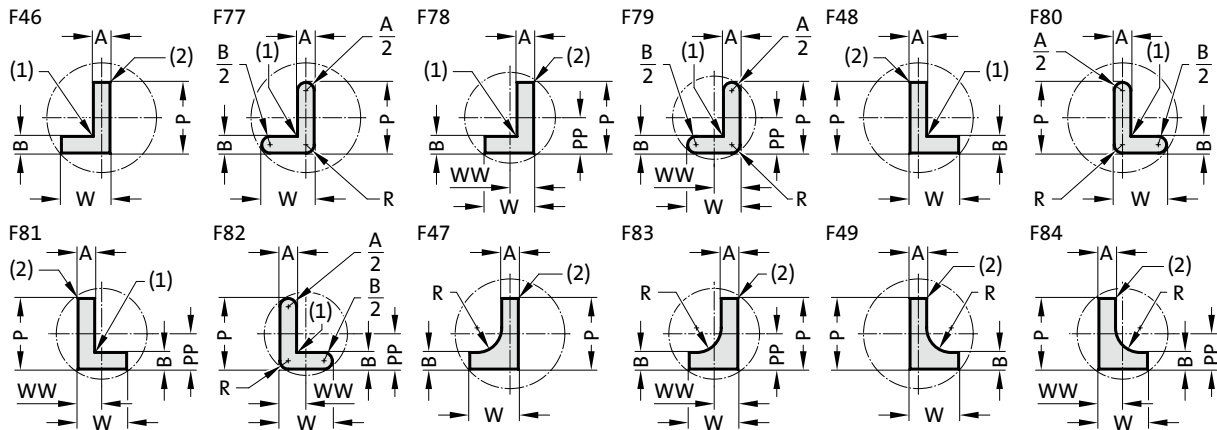

0°

U-shapes

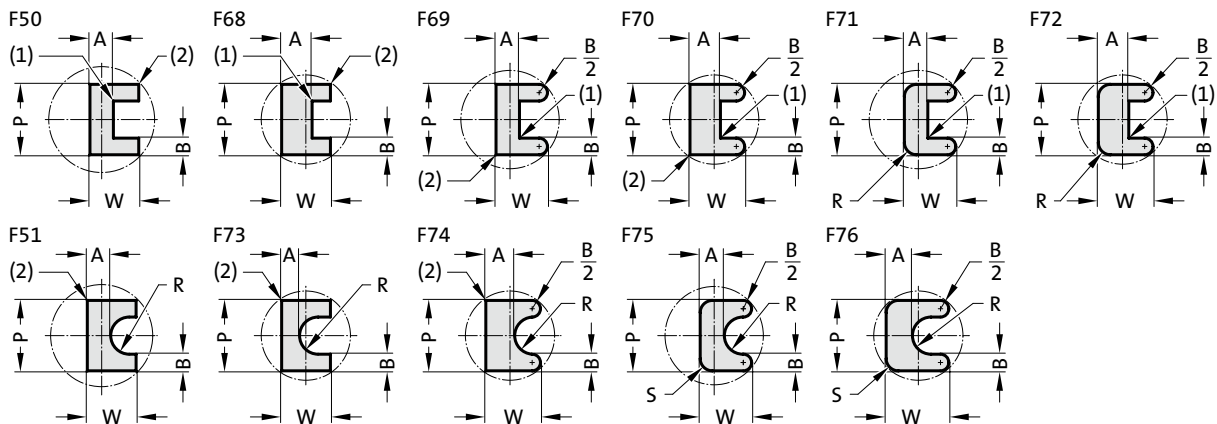

270°

DYNAMIC STRIPPING ELEMENT (DAE)



2618.

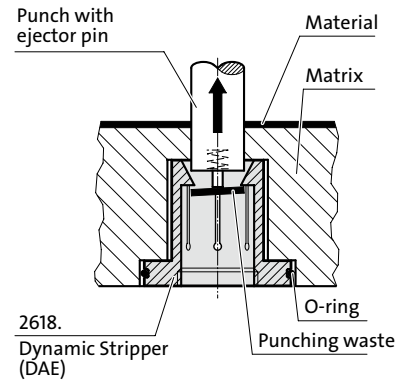
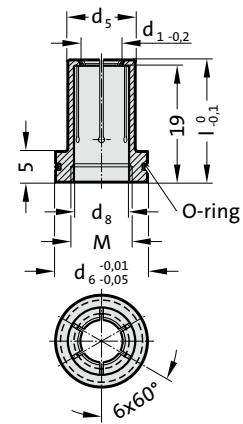

Description:

The dynamic stripper is used in blanking tools for punching operations using material up to 2 mm thick. The stripper is below the die. It is similar in shape to a segmented chuck. After the punching operation the punch enters the stripper with the punch waste still attached. The dynamic stripper opens up to receive the punch. On the return stroke the dynamic stripper strips the punch waste from the punch. The stripping element diameter d_1 is manufactured 0.2 mm smaller than the diameter p of the punch. To ensure reliable stripping the minimum entry depth into the dynamic stripper must be no less than 1 mm.

The dynamic stripper can help to protect both the tool and the product from damage and also accelerate the production rate.

Material:

Steel, hardened

Mounting example

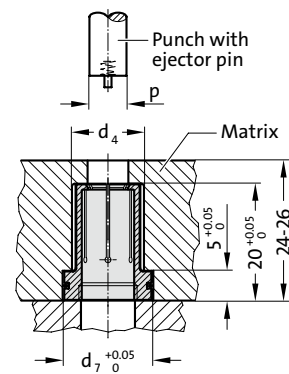

Mounting example

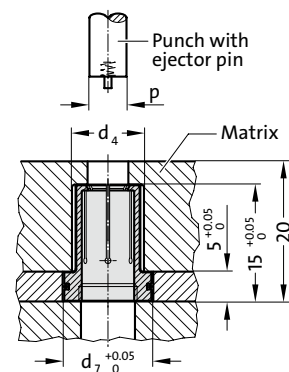

DYNAMIC STRIPPING ELEMENT (DAE)

2618. Dynamic stripping element (DAE)

Cutting punch p	DAE d ₁ Order-Ø	d ₅	d ₆	l	M	Matrix d ₄	d ₇
3.00-3.09	3	7	11	19.95	6	8	11
3.10-3.19	3.1	7	11	19.95	6	8	11
3.20-3.29	3.2	7	11	19.95	6	8	11
3.30-3.39	3.3	7	11	19.95	6	8	11
3.40-3.49	3.4	7	11	19.95	6	8	11
3.50-3.59	3.5	7	11	19.95	6	8	11
3.60-3.69	3.6	7	11	19.95	6	8	11
3.70-3.79	3.7	7	11	19.95	6	8	11
3.80-3.89	3.8	7	11	19.95	6	8	11
3.90-3.99	3.9	7	11	19.95	6	8	11
4.00-4.09	4	7	11	19.95	6	8	11
4.10-4.19	4.1	8	12	19.95	8	9	12
4.20-4.29	4.2	8	12	19.95	8	9	12
4.30-4.39	4.3	8	12	19.95	8	9	12
4.40-4.49	4.4	8	12	19.95	8	9	12
4.50-4.59	4.5	8	12	19.95	8	9	12
4.60-4.69	4.6	8	12	19.95	8	9	12
4.70-4.79	4.7	8	12	19.95	8	9	12
4.80-4.89	4.8	8	12	19.95	8	9	12
4.90-4.99	4.9	8	12	19.95	8	9	12
5.00-5.09	5	8	12	19.95	8	9	12
5.10-5.19	5.1	9	13	19.95	8	10	13
5.20-5.29	5.2	9	13	19.95	8	10	13
5.30-5.39	5.3	9	13	19.95	8	10	13
5.40-5.49	5.4	9	13	19.95	8	10	13
5.50-5.59	5.5	9	13	19.95	8	10	13
5.60-5.69	5.6	9	13	19.95	8	10	13
5.70-5.79	5.7	9	13	19.95	8	10	13
5.80-5.89	5.8	9	13	19.95	8	10	13
5.90-5.99	5.9	9	13	19.95	8	10	13
6.00-6.09	6	9	13	19.95	8	10	13
6.10-6.19	6.1	10	14	19.95	10	11	14
6.20-6.29	6.2	10	14	19.95	10	11	14
6.30-6.39	6.3	10	14	19.95	10	11	14
6.40-6.49	6.4	10	14	19.95	10	11	14
6.50-6.59	6.5	10	14	19.95	10	11	14
6.60-6.69	6.6	10	14	19.95	10	11	14
6.70-6.79	6.7	10	14	19.95	10	11	14
6.80-6.89	6.8	10	14	19.95	10	11	14
6.90-6.99	6.9	10	14	19.95	10	11	14
7.00-7.09	7	10	14	19.95	10	11	14
7.10-7.19	7.1	11	15	19.95	10	12	15
7.20-7.29	7.2	11	15	19.95	10	12	15
7.30-7.39	7.3	11	15	19.95	10	12	15
7.40-7.49	7.4	11	15	19.95	10	12	15
7.50-7.59	7.5	11	15	19.95	10	12	15
7.60-7.69	7.6	11	15	19.95	10	12	15
7.70-7.79	7.7	11	15	19.95	10	12	15
7.80-7.89	7.8	11	15	19.95	10	12	15
7.90-7.99	7.9	11	15	19.95	10	12	15
8.00-8.09	8	11	15	19.95	10	12	15

Ordering Code (example):

Dynamic stripping element (DAE)	=	2618.
Outer diameter d ₅	9 mm =	09.
Order length BL	20 mm =	020.
Order diameter d ₁	5.5 mm =	0550
Order No	=	2618. 09. 020. 0550

MATRIXES FOR DYNAMIC STRIPPER (DAE) - ORDERING CODE (EXAMPLE)

Note:

See table for standard dimensions

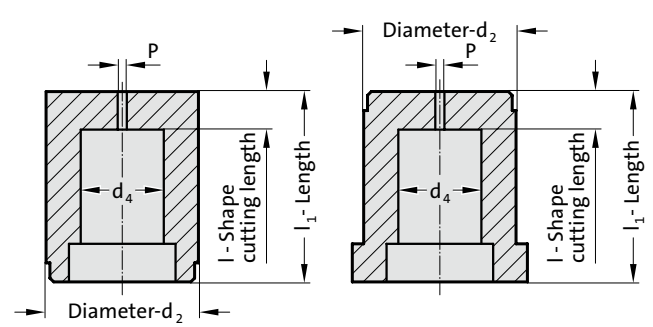
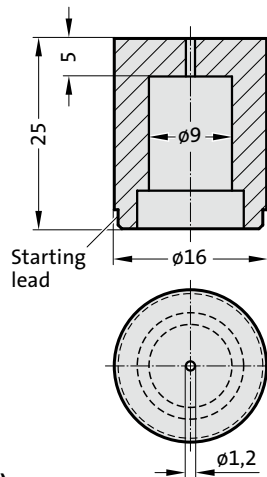

Ordering Code (example):

2618.06.6E4.09

- (09) $d_4 = 9$ mm
 - (4) **Shape cutting length:**
 $l = 5$ mm
 - (E) **Length:**
 $l_1 = 25$ mm
 - (6) **Diameter:**
 $d_2 = 16$ mm
 - (6) **Type:**
without collar for DAE
 - (0) **Execution:**
Blank
(pilot hole bore)
- Matrix for Dynamic Stripper (DAE)**
(2618)

- Shape cutting length: l Order No
5 = 4
 - Length: l_1 Order Code character
25 = E
 - Diameter: d_2 Order No
13 = 5
16 = 6
20 = 7
 - Type: Order No
without collar for DAE = 6
with collar for DAE = 7
 - Execution: Order No
blank (pilot hole bore) = 0
- Matrices for Dynamic Stripper (DAE)

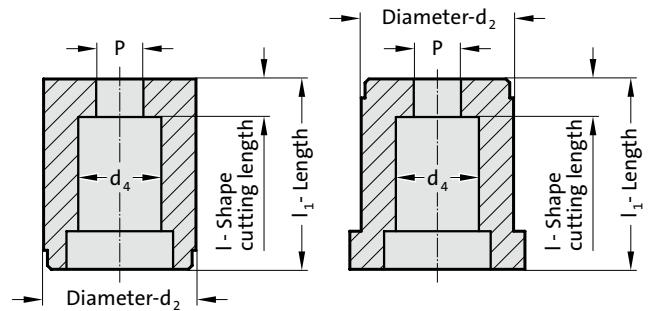
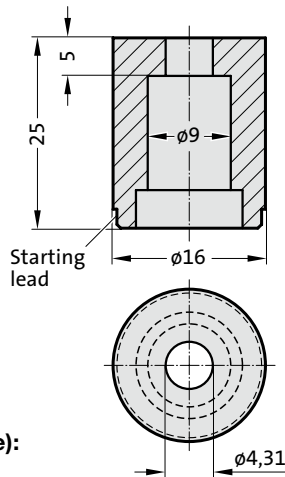

Ordering Code (example):

2618.16.6E4.0431

- (0431) **Format:**
round, $P = 4,31$ mm
 - (4) **Shape cutting length:**
 $l = 5$ mm
 - (E) **Length:**
 $l_1 = 25$ mm
 - (6) **Diameter:**
 $d_2 = 16$ mm
 - (6) **Type:**
without collar for DAE
 - (1) **Execution:**
round
- Matrix for Dynamic Stripper (DAE)**
(2618)

- Format: round, $P = 4,31$ mm
 - Shape cutting length: l Order No
5 = 4
 - Length: l_1 Order Code character
25 = E
 - Diameter: d_2 Order No
13 = 5
16 = 6
20 = 7
 - Type: Order No
without collar for DAE = 6
with collar for DAE = 7
 - Execution: Order No
round = 1
- Matrices for Dynamic Stripper (DAE)

MATRIX WITHOUT COLLAR FOR DYNAMIC STRIPPER (DAE), BLANK

2618.06.

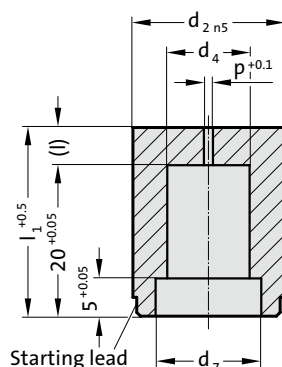

2618.06. Matrix without collar for dynamic stripper (DAE), blank

d ₂ / Order No	d ₄	d ₇	p	l / (Order No)	l ₁ / (Order Code character)
13 / (5)	8	11	1.2	5 / (4)	25/(E)
16 / (6)	9	12	1.2	5 / (4)	25/(E)
16 / (6)	10	13	1.5	5 / (4)	25/(E)
20 / (7)	11	14	1.5	5 / (4)	25/(E)
20 / (7)	12	15	1.5	5 / (4)	25/(E)

Ordering Code (example):

2618.06.6E4.09

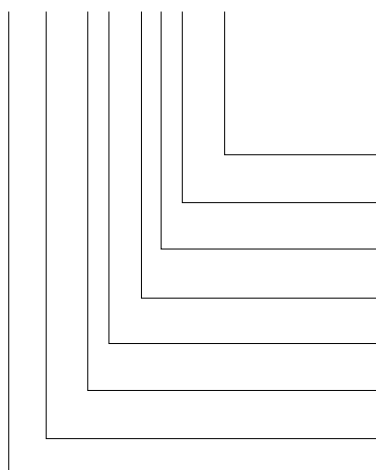

Diameter d₄
 9 mm = 09
Shape cutting length: l
 5 mm = (4)
Length: l₁
 25 mm = (E)
Diameter d₂
 16 mm = (6)
Type:
 without collar for DAE = (6)
Execution:
 blank (pilot hole bore) for Dynamic Stripper (DAE) = (0)
Matrix
 = 18
 = 26

Material:

HSS
 Hardness 62 ± 2 HRC

Execution:

Diameter d₂, starting lead and face surfaces ground.
 Diameter P is a bored pilot hole for wire EDM.

Note:

Order dynamic stripping element (DAE) separately.

MATRIX WITH COLLAR FOR DYNAMIC STRIPPER (DAE), BLANK



2618.07.

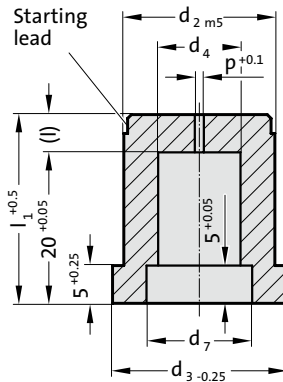

2618.07. Matrix with collar for dynamic stripper (DAE), blank

d ₂ / Order No	d ₃	d ₄	d ₇	p	l / (Order No)	l ₁ / (Order Code character)
13 / (5)	16	8	11	1.2	5 / (4)	25/(E)
16 / (6)	19	9	12	1.2	5 / (4)	25/(E)
16 / (6)	19	10	13	1.5	5 / (4)	25/(E)
20 / (7)	23	11	14	1.5	5 / (4)	25/(E)
20 / (7)	23	12	15	1.5	5 / (4)	25/(E)

Material:

HSS
Hardness 62 ± 2 HRC

Execution:

Diameter d₂, starting lead and face surfaces ground.
Diameter P is a bored pilot hole for wire EDM.

Note:

Order dynamic stripping element (DAE) separately.

Ordering Code (example):

2618.07.6E4.09

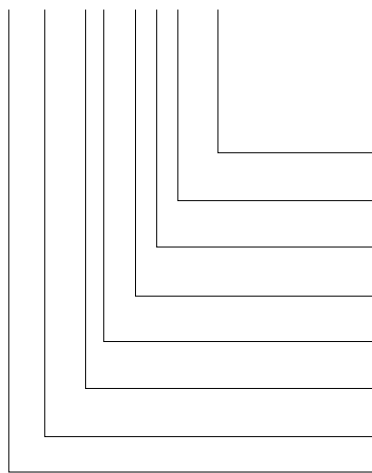

Diameter d₄
9 mm
Shape cutting length: l
5 mm
Length: l₁
25 mm
Diameter d₂
16 mm
Type:
with collar for DAE
Execution:
blank (pilot hole bore)
for Dynamic Stripper
(DAE)
Matrix

= 09
Order No
= (4)
Order Code character
= (E)
Order No
= (6)
Order No
= (7)
Order No
= (0)
= 18
= 26

MATRIX WITHOUT COLLAR FOR DYNAMIC STRIPPER (DAE), ROUND

2618.16.

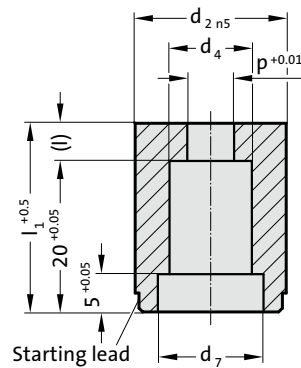

2618.16. Matrix without collar for dynamic stripper (DAE), round

d ₂ / Order No	d ₄	d ₇	l / (Order No)	l ₁ / (Order Code character)	Matrix	DAE	d ₁
					Diameter steps 0.01		
13 / (5)	8	11	5 / (4)	25/(E)	P	7	3-4
16 / (6)	9	12	5 / (4)	25/(E)	3 - 4,29	8	4,1-5
16 / (6)	10	13	5 / (4)	25/(E)	4,3 - 5,29	9	5,1-6
20 / (7)	11	14	5 / (4)	25/(E)	5,3 - 6,29	10	6,1-7
20 / (7)	12	15	5 / (4)	25/(E)	6,3 - 7,29	11	7,1-8
					7,3 - 8,29		

Ordering Code (example):

2618.16.6E4.0431

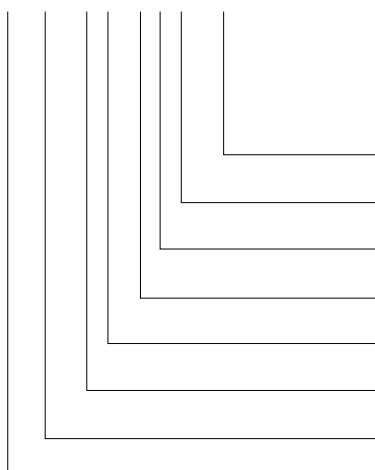

Shape: round

P = ø4,31 mm

Shape cutting length: l

5 mm

Length: l₁

25 mm

Diameter d₂

16 mm

Type:

without collar for DAE

Execution:

round
for Dynamic Stripper
(DAE)

Matrix

= 0431

Order No

= (4)

Order Code character

= (E)

Order No

= (6)

Order No

= (6)

Order No

= (1)

= 18

= 26

Material:

HSS

Hardness 62 ± 2 HRC

Execution:

Diameter d₂, starting lead and end faces
ground.

Note:

Order dynamic stripping element (DAE)
separately.

MATRIX WITH COLLAR FOR DYNAMIC STRIPPER (DAE), ROUND



2618.17.

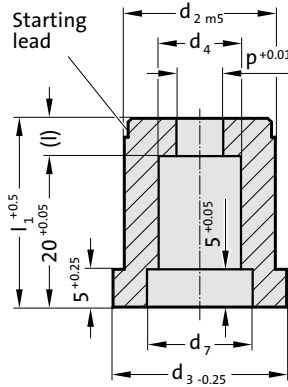

2618.17. Matrix with collar for dynamic stripper (DAE), round

d ₂ / Order No	d ₃	d ₄	d ₇	l / (Order No)	l ₁ / (Order Code character)	Matrix Diameter steps 0.01 P	DAE d ₅	d ₁ Gradation 0.1
13 / (5)	16	8	11	5 / (4)	25/(E)	3 - 4,29	7	3-4
16 / (6)	19	9	12	5 / (4)	25/(E)	4,3 - 5,29	8	4,1-5
16 / (6)	19	10	13	5 / (4)	25/(E)	5,3 - 6,29	9	5,1-6
20 / (7)	23	11	14	5 / (4)	25/(E)	6,3 - 7,29	10	6,1-7
20 / (7)	23	12	15	5 / (4)	25/(E)	7,3 - 8,29	11	7,1-8

Material:

HSS
Hardness 62 ± 2 HRC

Execution:

Diameter d₂, starting lead and end faces ground.

Note:

Order dynamic stripping element (DAE) separately.

Ordering Code (example):

2618.17.6E4.0431

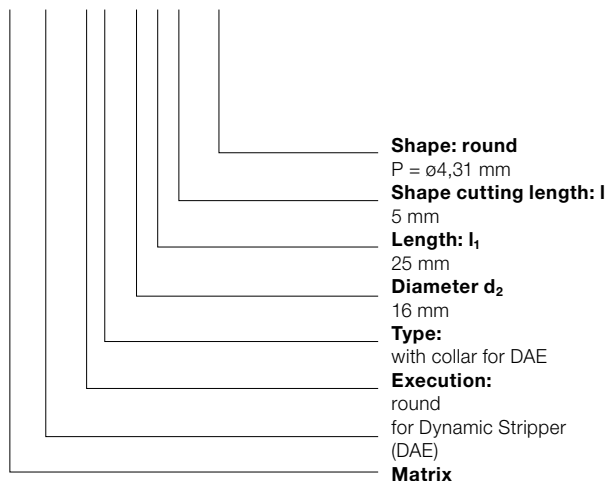

= 0431
Order No
 = (4)
Order Code character
 = (E)
Order No
 = (6)
Order No
 = (7)
Order No
 = (1)
 = 18
 = 26

TRIANGLE RETAINERS FOR BALL-LOCK PUNCHES



TRIANGLE RETAINER FOR BALL-LOCK PUNCHES, LIGHT DUTY

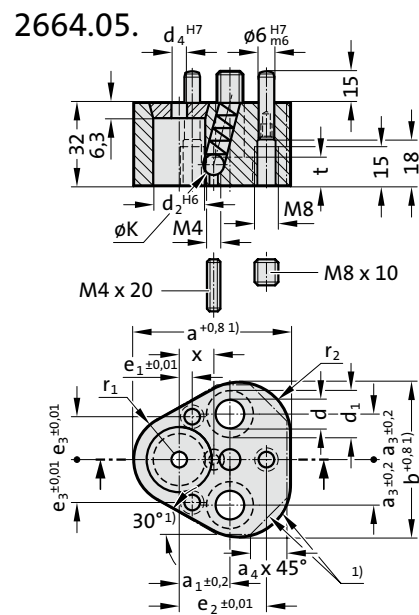
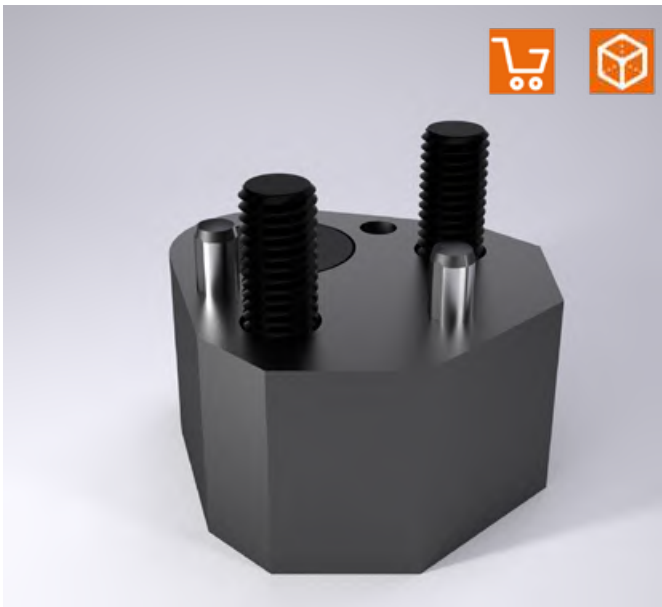

Execution:

Version for metal thicknesses up to 3 mm. The punch locating hole d_2 is manufactured to a tolerance of ± 0.01 mm relative to the 6 stud holes H7. This ensures the interchangeability of the locating plate with other polygon versions.

Note:

Special punch retainers available to order.

1) Contours may vary. Maximum dimensions are specified in the table.

2664.05. Triangle retainer for ball-lock punches, light duty

Order No	d	d ₁	d ₂	d ₄	a	a ₁	a ₃	a ₄	b	e ₁	e ₂	e ₃	ØK	t	r ₁	r ₂	x
2664.05.10	9	15	10	6	44.5	19	11.1	10	43.7	7.5	26.925	9	8	9	9.5	12	8.2
2664.05.13	9	15	13	6	50.8	19	14.3	12	50	6.5	29.97	12	8	9	12.7	15.2	9.5
2664.05.16	9	15	16	6	54	19	15.9	13	53.2	6	31.75	13.5	8	9	14.3	16.8	11.2
2664.05.20	11	18	20	6	60.3	19	17.5	14	59.5	5	33.53	16.5	8	11	17.5	20	13.2
2664.05.25	13.5	20	25	6	69.9	23.8	19.8	16	69.1	7	40.64	22	8	13.5	22.2	24.7	15.7
2664.05.32	13.5	20	32	6	69.9	23.8	19.8	16	69.1	7	40.64	22	8	13.5	22.2	24.7	19.25
2664.05.38	13.5	20	38	6	77.4	27	24	18	76.6	10	43.993	26	8	13.5	26	28.5	22.25

TRIANGLE RETAINER FOR BALL-LOCK PUNCHES, HEAVY DUTY

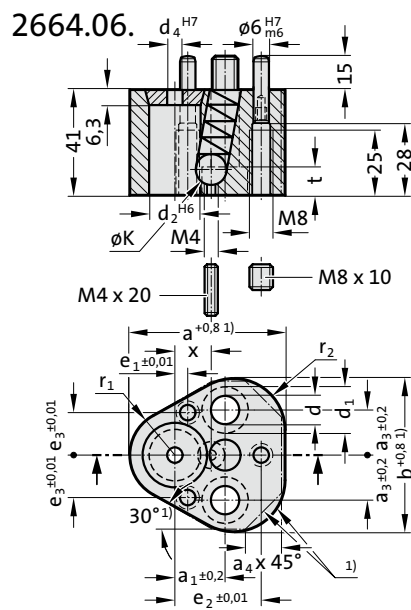

Execution:

Version for metal thicknesses ≥ 3 mm/max. 6 mm. The punch locating hole d_2 is manufactured to a tolerance of ± 0.01 mm relative to the 6 stud holes H7. This ensures the interchangeability of the locating plate with other polygon versions.

Note:

Special punch retainers available to order.

1) Contours may vary. Maximum dimensions are specified in the table.

2664.06. Triangle retainer for ball-lock punches, heavy duty

Order No	d	d ₁	d ₂	d ₄	a	a ₁	a ₃	a ₄	b	e ₁	e ₂	e ₃	ØK	t	r ₁	r ₂	x
2664.06.10	9	15	10	6	44.5	19	11.1	10	43.7	7.5	26.925	9	10	9	9.5	12	9.8
2664.06.13	9	15	13	6	50.8	19	14.3	12	50	6.5	29.97	12	12	9	12.7	15.2	11.3
2664.06.16	9	15	16	6	54	19	15.9	13	53.2	6	31.75	13.5	12	9	14.3	16.8	12.8
2664.06.20	11	18	20	6	60.3	19	17.5	14	59.5	5	33.53	16.5	12	11	17.5	20	14.8
2664.06.25	13.5	20	25	6	69.9	23.8	19.8	16	69.1	7	40.64	22	12	13.5	22.2	24.7	17.3
2664.06.32	13.5	20	32	6	69.9	23.8	19.8	16	69.1	7	40.64	22	12	13.5	22.2	24.7	20.8
2664.06.40	13.5	20	40	6	77.4	27	24	18	76.6	10	43.993	26	12	13.5	26	28.5	24.8

TRIANGLE RETAINER FOR BALL-LOCK PUNCHES, LIGHT DUTY

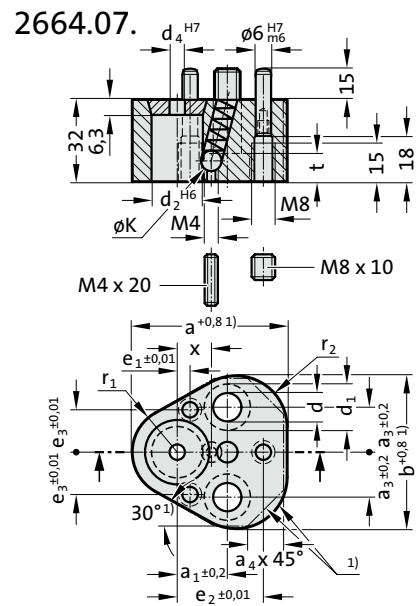

Execution:

Version for metal thicknesses up to 3 mm. The punch locating hole d_2 is manufactured to a tolerance of ± 0.01 mm relative to the 6 stud holes H7. This ensures the interchangeability of the locating plate with other polygon versions.

Note:

Special punch retainers available to order.

1) Contours may vary. Maximum dimensions are specified in the table.

2664.07. Triangle retainer for ball-lock punches, light duty

Order No	d	d ₁	d ₂	d ₄	a	a ₁	a ₃	a ₄	b	e ₁	e ₂	e ₃	ØK	t	r ₁	r ₂	x
2664.07.06	6.6	11	6	3	35	19	11.1	6	37.5	9	23	8	6	7	8	8	5.7

TRIANGLE RETAINER FOR BALL-LOCK PUNCHES, HEAVY DUTY

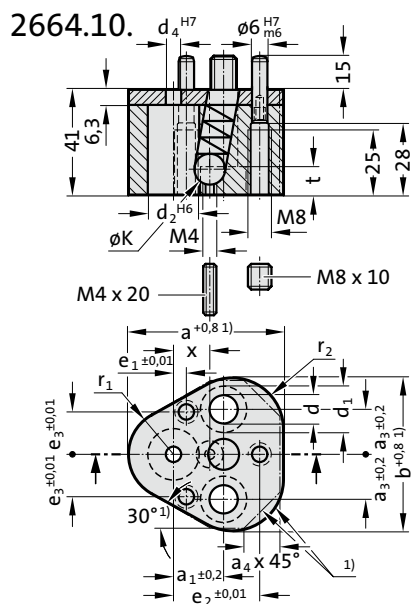

Execution:

Version for metal thicknesses ≥ 3 mm/max. 6 mm. The punch locating hole d_2 is manufactured to a tolerance of ± 0.01 mm relative to the 6 stud holes H7. This ensures the interchangeability of the locating plate with other polygon versions.

Note:

Special punch retainers available to order.
Pressure plate welded.

1) Contours may vary. Maximum dimensions are specified in the table.

2664.10. Triangle retainer for ball-lock punches, heavy duty

Order No	d	d ₁	d ₂	d ₄	a	a ₁	a ₃	a ₄	b	e ₁	e ₂	e ₃	ØK	t	r ₁	r ₂	x
2664.10.10	9	15	10	6	44.5	19	11.1	10	43.7	7.5	26.925	9	10	9	9.5	12	9.8
2664.10.13	9	15	13	6	50.8	19	14.3	12	50	6.5	29.97	12	12	9	12.7	15.2	11.3
2664.10.16	9	15	16	6	54	19	15.9	13	53.2	6	31.75	13.5	12	9	14.3	16.8	12.8
2664.10.20	11	18	20	6	60.3	19	17.5	14	59.5	5	33.53	16.5	12	11	17.5	20	14.8
2664.10.25	13.5	20	25	6	69.9	23.8	19.8	16	69.1	7	40.64	22	12	13.5	22.2	24.7	17.3
2664.10.32	13.5	20	32	6	69.9	23.8	19.8	16	69.1	7	40.64	22	12	13.5	22.2	24.7	20.8
2664.10.40	13.5	20	40	6	77.4	27	24	18	76.6	10	43.993	26	12	13.5	26	28.5	24.8

ACCESSORIES FOR RETAINERS, TRIANGULAR, FOR BALL-LOCK PUNCHES

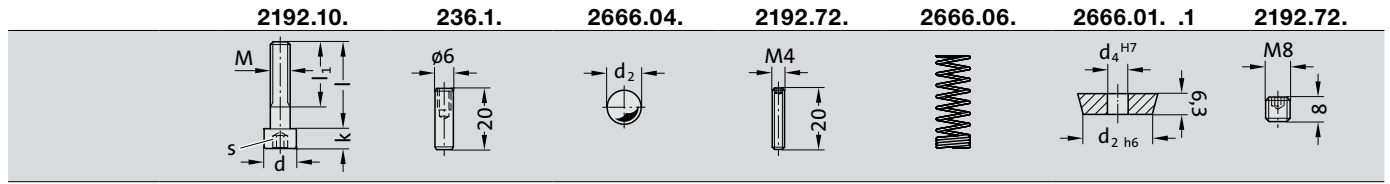

Retainer	ø d ₂	Socket head cap screw	Dowel pin	Ball	Ball release pin	Spring	Pressure disk for centring pin	Pin screw
2664.05.	10	2192.10.08.035	236.1.0600.020	2666.04.008	2192.72.04.020	2666.06.008	2666.01.10.1	2192.72.08.008
	13	2192.10.08.035	236.1.0600.020	2666.04.008	2192.72.04.020	2666.06.008	2666.01.13.1	2192.72.08.008
	16	2192.10.08.035	236.1.0600.020	2666.04.008	2192.72.04.020	2666.06.008	2666.01.16.1	2192.72.08.008
	20	2192.10.10.035	236.1.0600.020	2666.04.008	2192.72.04.020	2666.06.008	2666.01.20.1	2192.72.08.008
	25	2192.10.12.035	236.1.0600.020	2666.04.008	2192.72.04.020	2666.06.008	2666.01.25.1	2192.72.08.008
	32	2192.10.12.035	236.1.0600.020	2666.04.008	2192.72.04.020	2666.06.008	2666.01.32.1	2192.72.08.008
	38	2192.10.12.035	236.1.0600.020	2666.04.008	2192.72.04.020	2666.06.008	2666.01.38.1	2192.72.08.008
2664.06./10.	10	2192.10.08.040	236.1.0600.020	2666.04.010	2192.72.04.020	2666.06.010	2666.01.10.1	2192.72.08.008
	13	2192.10.08.040	236.1.0600.020	2666.04.012	2192.72.04.020	2666.06.012	2666.01.13.1	2192.72.08.008
	16	2192.10.08.040	236.1.0600.020	2666.04.012	2192.72.04.020	2666.06.012	2666.01.16.1	2192.72.08.008
	20	2192.10.10.050	236.1.0600.020	2666.04.012	2192.72.04.020	2666.06.012	2666.01.20.1	2192.72.08.008
	25	2192.10.12.050	236.1.0600.020	2666.04.012	2192.72.04.020	2666.06.012	2666.01.25.1	2192.72.08.008
	32	2192.10.12.050	236.1.0600.020	2666.04.012	2192.72.04.020	2666.06.012	2666.01.32.1	2192.72.08.008
	40	2192.10.12.050	236.1.0600.020	2666.04.012	2192.72.04.020	2666.06.012	2666.01.40.1	2192.72.08.008
2664.07.	6	2192.10.06.035	236.1.0600.020	2666.04.006	2192.72.04.020	2666.06.006	2666.01.06.1	2192.72.08.008

Ball release tool

Hook shape	straight shape	straight shape with threaded tip
2666.05.01	2666.05.02	2666.05.03

ACCU-LOCK FIXTURE DEVICE FOR BALL-LOCK PUNCHES, LIGHT DUTY

2668.2.

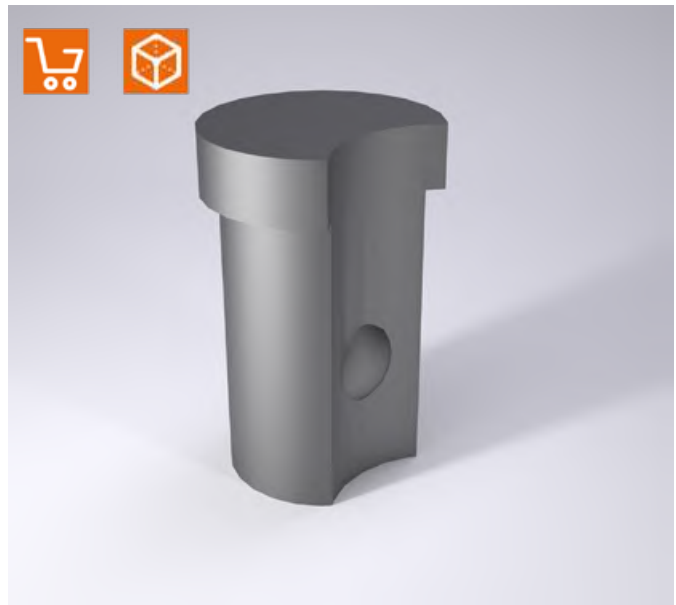
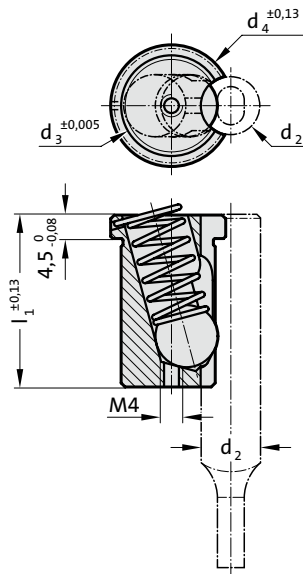

Note:

Use ball release tool 2666.05.02, straight.

Mounting example

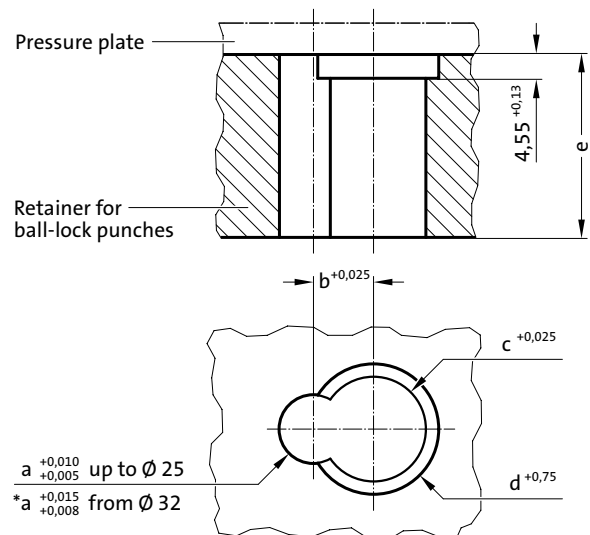

2668.2. ACCU-LOCK Fixture device for ball-lock punches, light duty

Order No	d ₂	d ₃	d ₄	l ₁	a	b	c	d	e
2668.2.06	6	12	14.6	25.7	6	6.5	12.013	15	25.7
2668.2.10	10	14	16.6	25.7	10	9	14.013	17	25.7
2668.2.13	13	14	16.6	25.7	13	10.5	14.013	17	25.7
2668.2.16	16	14	16.6	25.7	16	12	14.013	17	25.7
2668.2.20	20	16	18.6	25.7	20	14	16.013	19	25.7
2668.2.25	25	16	18.6	25.7	25	16.5	16.013	19	25.7
2668.2.32	32	16	18.6	25.7	32	20	16.013	19	25.7
2668.2.38	38	16	18.6	25.7	38	23	16.013	19	25.7

ACCU-LOCK FIXTURE DEVICE FOR BALL-LOCK PUNCHES, HEAVY DUTY

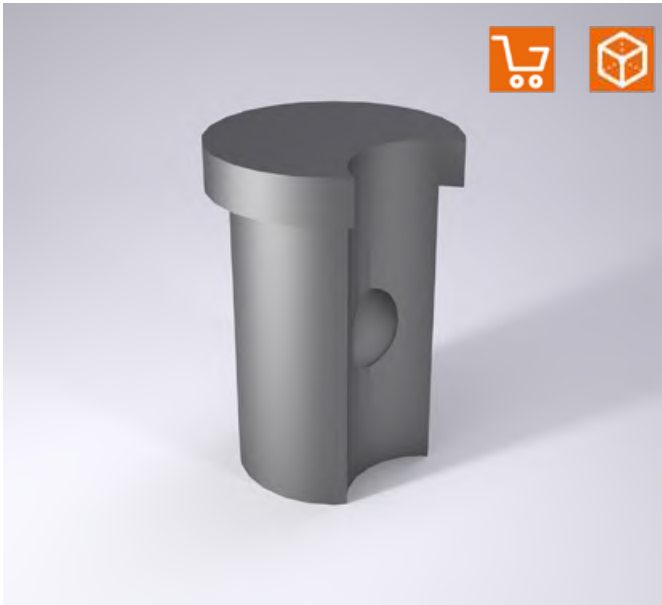

2668.3.

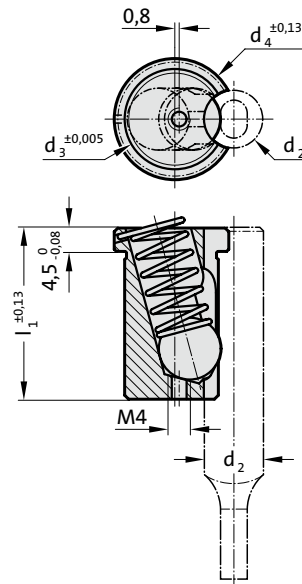

Mounting example

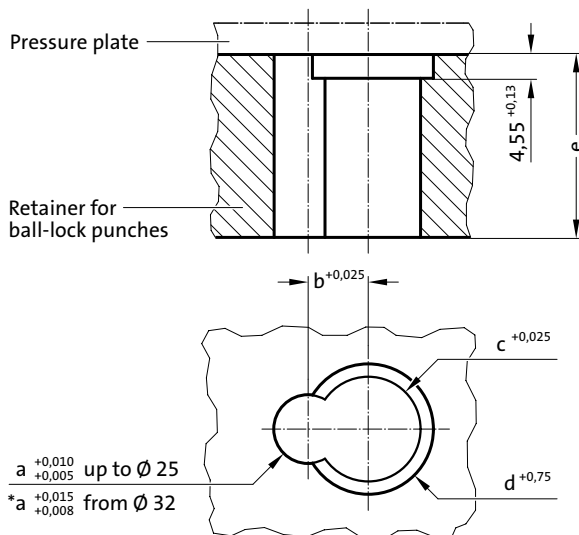

Note:

Use ball release tool 2666.05.02, straight.

2668.3. ACCU-LOCK Fixture device for ball-lock punches, heavy duty

Order No	d ₂	d ₃	d ₄	l ₁	a	b	c	d	e
2668.3.10	10	16	19.6	34.7	10	10	16.013	20	34.7
2668.3.13	13	20	24.6	34.7	13	11.5	20.013	25	34.7
2668.3.16	16	20	24.6	34.7	16	13	20.013	25	34.7
2668.3.20	20	20	24.6	34.7	20	15	20.013	25	34.7
2668.3.25	25	20	24.6	34.7	25	17.5	20.013	25	34.7
2668.3.32	32	20	24.6	34.7	32	21	20.013	25	34.7
2668.3.40	40	20	24.6	34.7	40	25	20.013	25	34.7

**RETAINERS
BOLT LOCK**

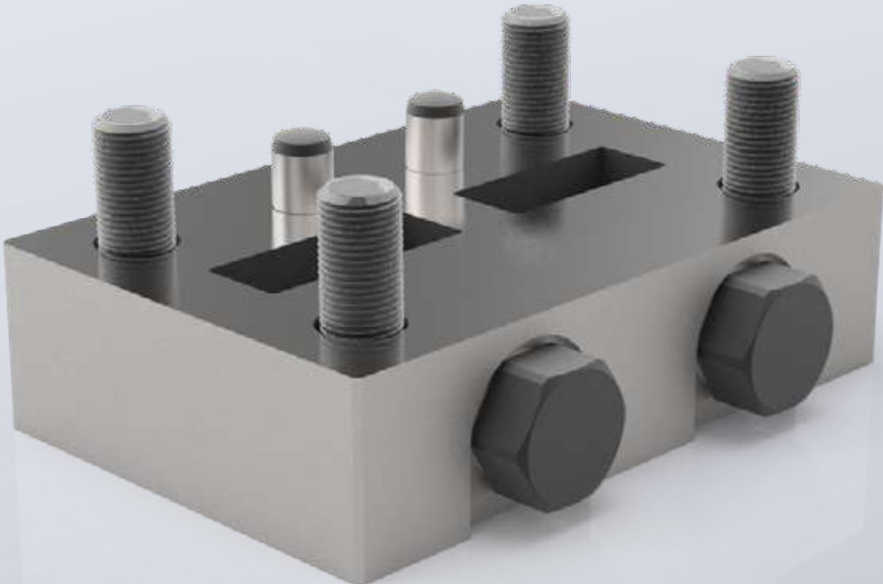

RETAINER BOLT LOCK

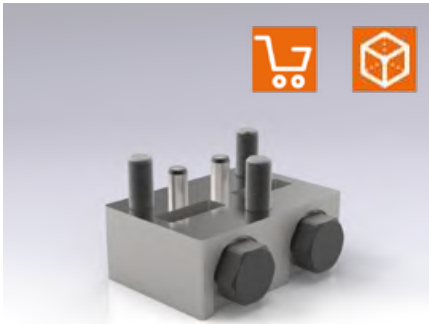

2664.11.01

Material:

HWS (1.2379)
Hardness 60 +2 HRC

Note:

Delivery including socket cap screws
DIN EN ISO 4762 and pins
DIN EN ISO 8735

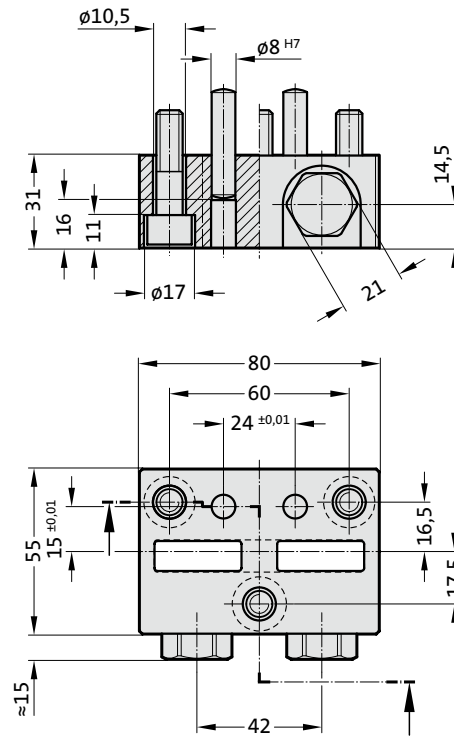

2664.11.02

Material:

HWS (1.2379)
Hardness 60 +2 HRC

Note:

Delivery including socket cap screws
DIN EN ISO 4762 and pins
DIN EN ISO 8735

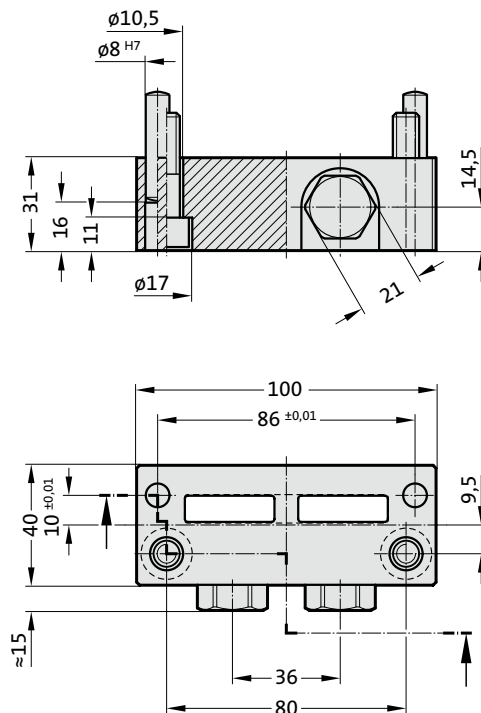

RETAINER BOLT LOCK

2664.11.03

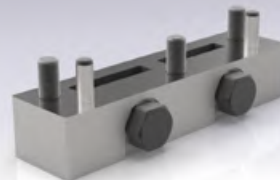
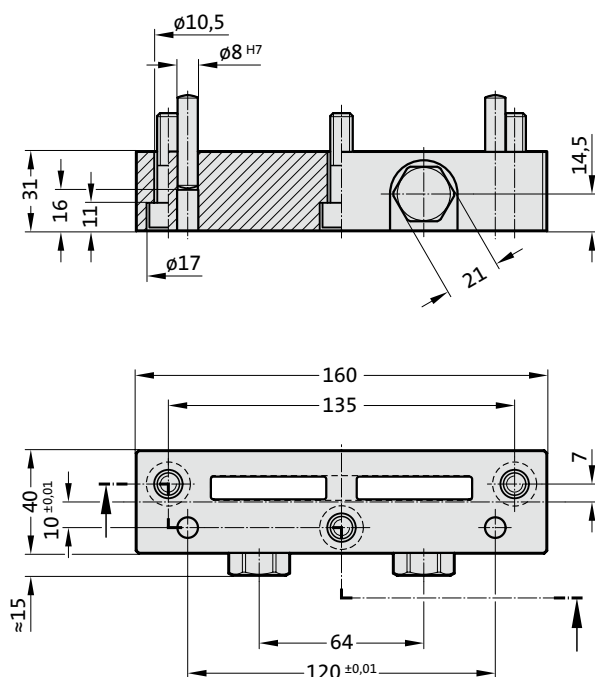

Material:

HWS (1.2379)

Hardness 60 +2 HRC

Note:

Delivery including socket cap screws

DIN EN ISO 4762 and pins

DIN EN ISO 8735

2664.11.04

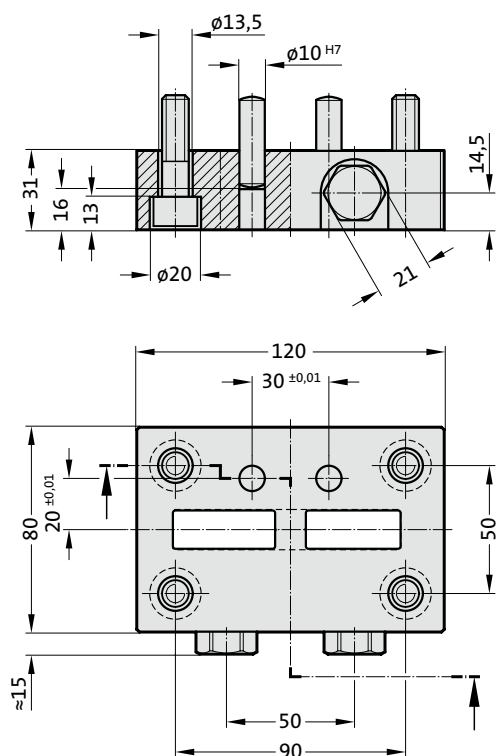

Material:

HWS (1.2379)

Hardness 60 +2 HRC

Note:

Delivery including socket cap screws

DIN EN ISO 4762 and pins

DIN EN ISO 8735

RETAINER BOLT LOCK



2664.11.05

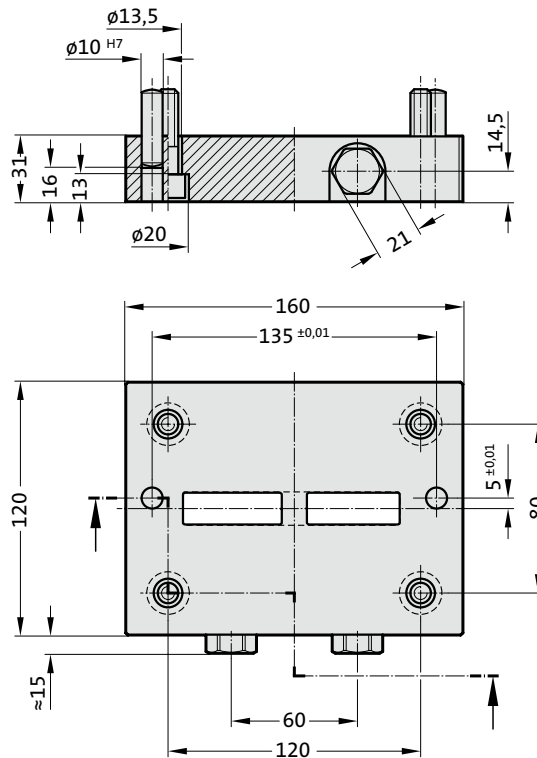

Material:

HWS (1.2379)

Hardness 60 +2 HRC

Note:

Delivery including socket cap screws

DIN EN ISO 4762 and pins

DIN EN ISO 8735



2664.11.06

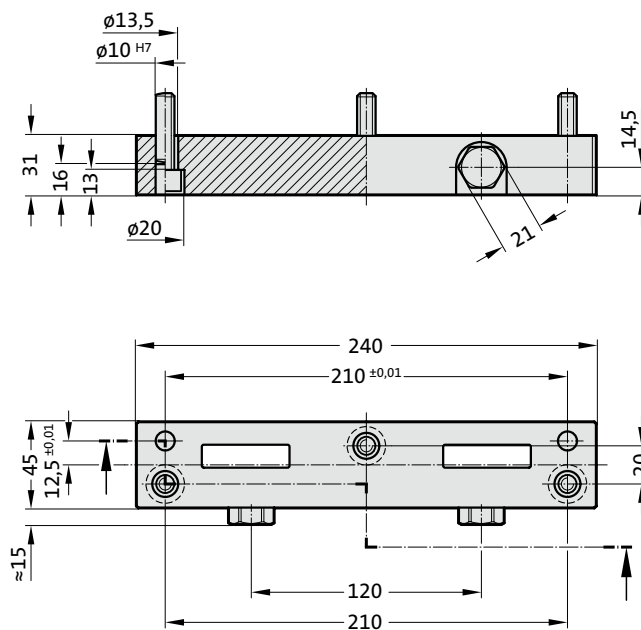

Material:

HWS (1.2379)

Hardness 60 +2 HRC

Note:

Delivery including socket cap screws

DIN EN ISO 4762 and pins

DIN EN ISO 8735

TRIANGLE RETAINERS FOR PUNCHES ISO 8020



TRIANGLE RETAINER, FOR PUNCHES ISO 8020 WITHOUT ANTI-ROTATION ELEMENT

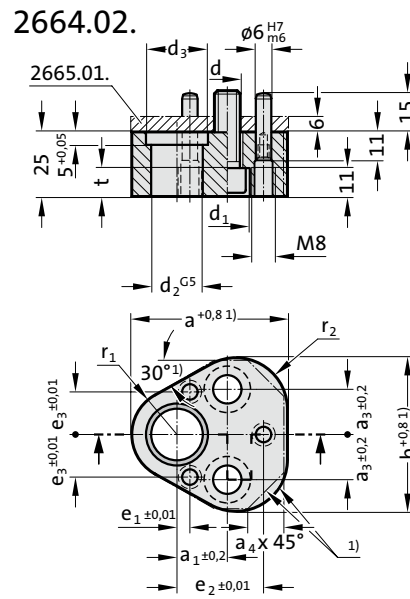

Execution:

The centres of the pinholes are the reference points for the position of the punch bore.

The dimensions e_1 , e_2 and e_3 have a tolerance of ± 0.01 mm.

The triangle ball-lock retainers are interchangeable.

Note:

Pressure plate 2665.01. to be ordered separately for the receiving punch plate.

1) Contours may vary. Maximum dimensions are specified in the table.

2664.02. Triangle retainer, for punches ISO 8020 without anti-rotation element

Order No	d	d ₁	d ₂	d ₃	a	a ₁	a ₃	a ₄	b	e ₁	e ₂	e ₃	t	r ₁	r ₂
2664.02.10	9	15	10	14	44.5	19	11.1	10	43.7	7.5	26.925	9	9	9.5	12
2664.02.13	9	15	13	17	50.8	19	14.3	12	50	6.5	29.97	12	9	12.7	15.2
2664.02.16	9	15	16	20	54	19	15.9	13	53.2	6	31.75	13.5	9	14.3	16.8
2664.02.20	11	18	20	24	60.3	19	17.5	14	59.5	5	33.53	16.5	11	17.5	20
2664.02.25	13.5	20	25	29	69.9	23.8	19.8	16	69.1	7	40.64	22	13.5	22.2	24.7
2664.02.32	13.5	20	32	36	69.9	23.8	19.8	16	69.1	7	40.64	22	13.5	22.2	24.7

TRIANGLE RETAINER, FOR PUNCHES ISO 8020 WITH ANTI-ROTATION ELEMENT

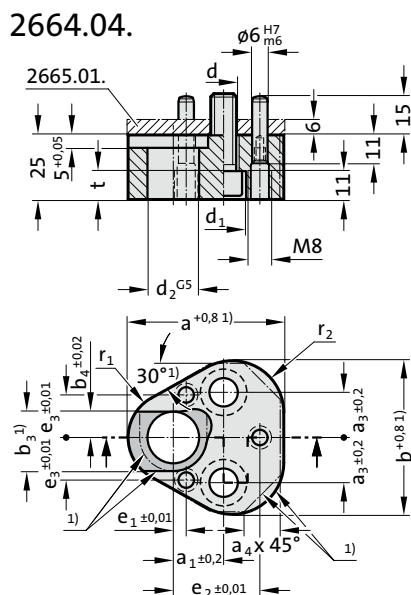

Execution:

The centres of the pinholes are the reference points for the position of the punch bore.

The dimensions e_1 , e_2 and e_3 have a tolerance of ± 0.01 mm.

The triangle ball-lock retainers are interchangeable.

Note:

Pressure plate 2665.01. to be ordered separately for the receiving punch plate.

1) Contours may vary. Maximum dimensions are specified in the table.

2664.04. Triangle retainer, for punches ISO 8020 with anti-rotation element

Order No	d	d ₁	d ₂	a	a ₁	a ₃	a ₄	b	b ₃	b ₄	e ₁	e ₂	e ₃	t	r ₁	r ₂
2664.04.10	9	15	10	44.5	19	11.1	10	43.7	12	5	7.5	26.925	9	9	9.5	12
2664.04.13	9	15	13	50.8	19	14.3	12	50	15	6.5	6.5	29.97	12	9	12.7	15.2
2664.04.16	9	15	16	54	19	15.9	13	53.2	18	8	6	31.75	13.5	9	14.3	16.8
2664.04.20	11	18	20	60.3	19	17.5	14	59.5	22	10	5	33.53	16.5	11	17.5	20
2664.04.25	13.5	20	25	69.9	23.8	19.8	16	69.1	27	12.5	7	40.64	22	13.5	22.2	24.7
2664.04.32	13.5	20	32	69.9	23.8	19.8	16	69.1	34	16	7	40.64	22	13.5	22.2	24.7

ACCESSORIES FOR RETAINERS, TRIANGULAR, FOR PUNCHES TO ISO 8020

2192.10.

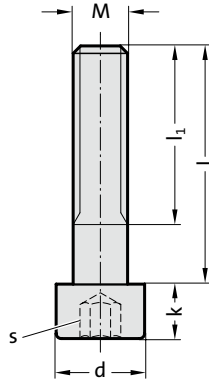

236.1.

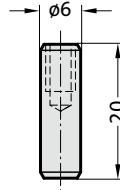

2192.72.

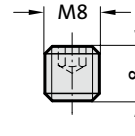

2665.01.

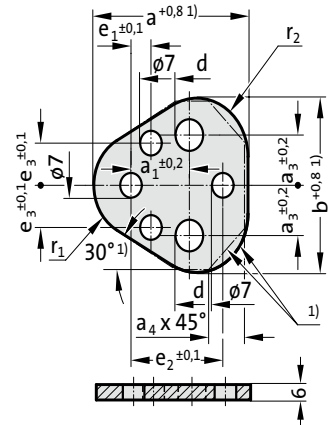

Retainer	Ø d ₂	Socket head cap screw	Dowel pin	Pin screw	Pressure plate
2664.02./04.	10	2192.10.08.035	236.1.0600.020	2192.72.08.008	2665.01.10
	13	2192.10.08.035	236.1.0600.020	2192.72.08.008	2665.01.13
	16	2192.10.08.035	236.1.0600.020	2192.72.08.008	2665.01.16
	20	2192.10.10.035	236.1.0600.020	2192.72.08.008	2665.01.20
	25	2192.10.12.035	236.1.0600.020	2192.72.08.008	2665.01.25
	32	2192.10.12.035	236.1.0600.020	2192.72.08.008	2665.01.32

ACCESSORIES

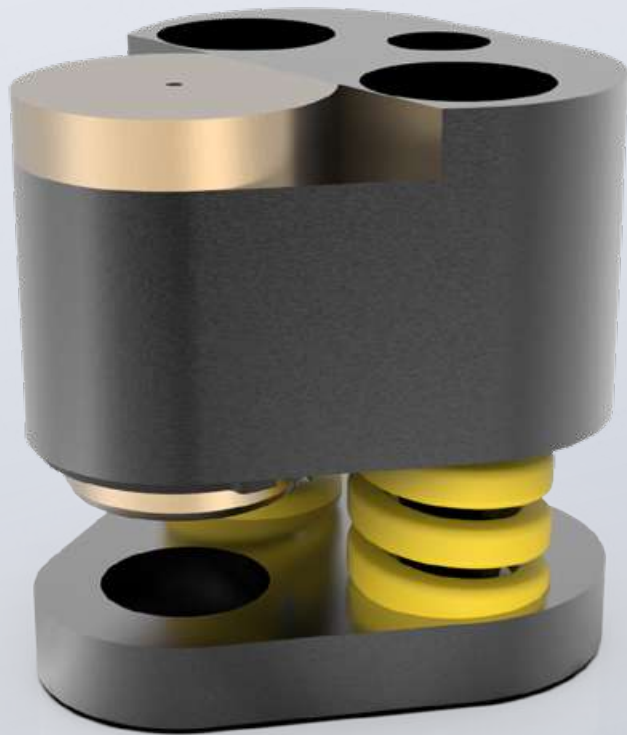

ELASTOMER STRIPPER



2431.7.

Mounting example:

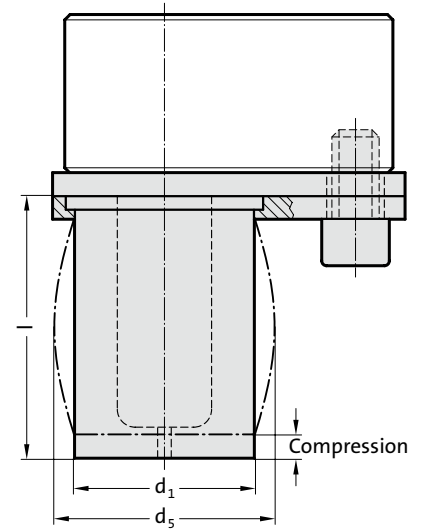
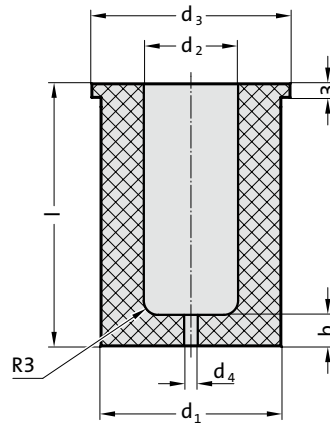

Material:

FIBROFLEX® 95 Shore A

Note:

Stripping units can be used for retainers 2664.02./04./05./06./10.

* values for the stripping force are dependent on a number of parameters (e.g. lubricant, temperature etc.) and may vary from those given here.

** max spring travel should not exceed 15% of the length

2431.7. Elastomer Stripper

d ₂	d ₁	d ₃	d ₄	d ₅ max.	b	Stripping unit length l				
						35	43	53	63	73
10	18	21	1,6	22	6	○	●	●	●	
13	23	26	3	26,5	6	○	●	●	●	●
16	28	31	3	34	6	○	●	●	●	●
20	33	36	3	38	7	○	●	●	●	●
25	40	43	3	47,6	7	○	●	●	●	●
32	50	55	3	57,9	7	○	●	●	●	●
38	60	65	3	69,6	8	○	○	○	○	○
40	60	65	3	69,6	8		●	●	●	○
						Punch lengths in use				
Ball-lock punch, light duty						63	71	80	90	100
Ball-lock punch, heavy duty						71	80	90	100	110
Precision punch ISO 8020						-	71	80	90	100
○ = Special measures upon request										

stroke**	3mm			6mm			9mm			3mm			6mm			9mm		
	35	35	35	43	43	43	53	53	53	63	63	63	73	73	73	73	73	
d ₂	Stripping forces (N)*																	
10	1300	-	-	1060	1820	-	900	1650	-	720	1450	1860	-	-	-	-	-	-
13	2100	-	-	1700	2850	-	1460	2610	-	1170	2320	2910	930	2080	2500	-	-	-
16	3000	-	-	2310	3900	-	1990	3560	-	1590	3150	3980	1270	2810	3440	-	-	-
20	3500	-	-	2900	4900	-	2500	4470	-	2000	3950	5000	1590	3420	4330	-	-	-
25	5400	-	-	4440	7520	-	3810	6860	-	3050	6050	7680	2420	5390	6780	-	-	-
32	8400	-	-	6840	11390	-	5880	10450	-	4700	9310	11640	3740	8370	10280	-	-	-
38	-	-	-	9280	19740	-	8140	15890	-	6440	11570	18030	5460	8850	11680	-	-	-
40	-	-	-	10100	20190	-	8650	17300	-	6890	13780	20670	6000	9800	12700	-	-	-

Ordering Code (example):

Elastomer Stripper = 2431.7.

d₂ = 10 mm = 10.

l = 53 mm = 53

Order No = 2431.7.10.53

STRIPPING UNIT - PRESSURE PLATE

2667.1.

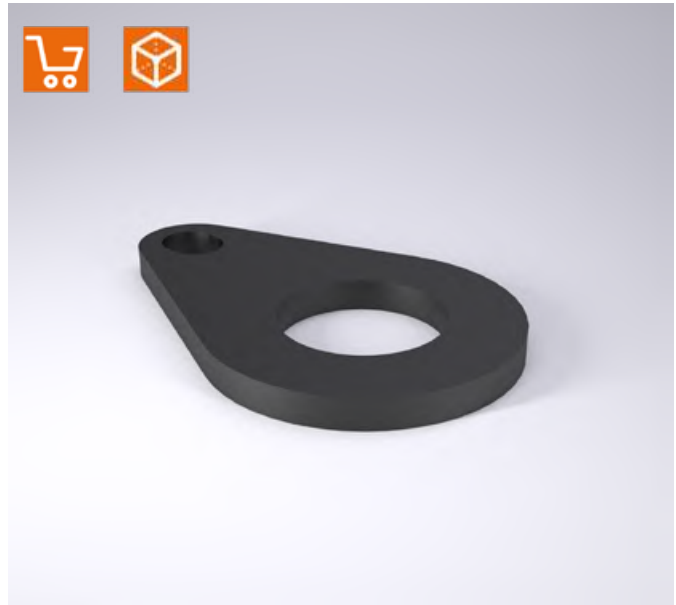
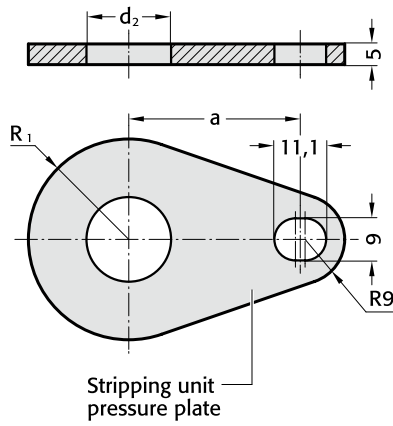

2667.1. Stripping unit - Pressure plate

Order No	d ₂	R ₁	a
2667.1.010	10	13	28
2667.1.013	13	15.5	31
2667.1.016	16	18	32.9
2667.1.020	20	20.5	34.8
2667.1.025	25	24	39.8
2667.1.032	32	31	41.3
2667.1.038	38	36	45
2667.1.040	40	36	45

Note:

Pressure plate, mounting plate and screw must all be ordered individually.

Mounting example

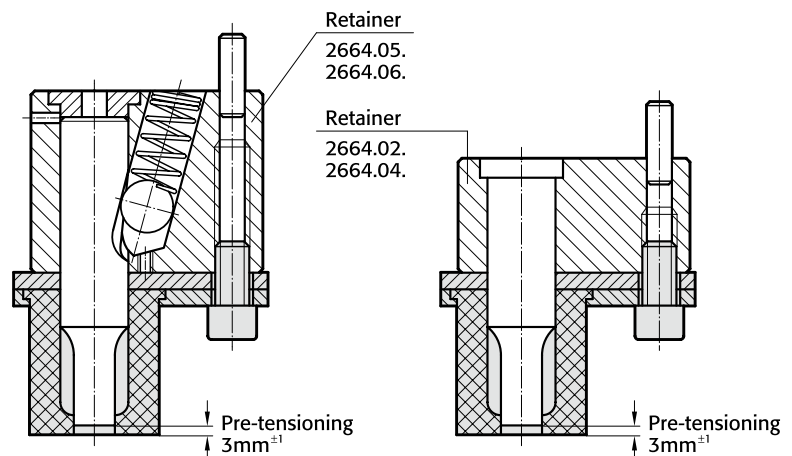

STRIPPING UNIT - MOUNTING PLATE



2667.2.

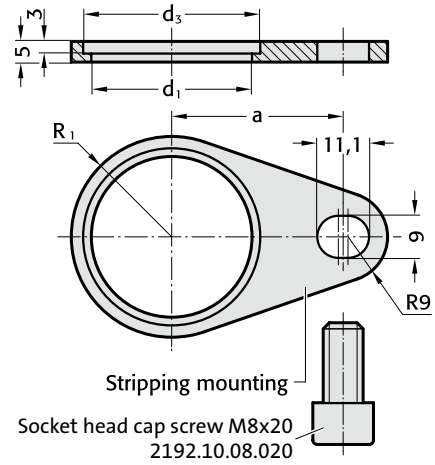

Note:

Pressure plate, mounting plate and screw must all be ordered individually.

2667.2. Stripping unit - Mounting plate

Order No	d ₂	d ₁	d ₃	R ₁	a
2667.2.010	10	19	22	13	28
2667.2.013	13	24	27	15.5	31
2667.2.016	16	29	32	18	32.9
2667.2.020	20	34	37	20.5	34.8
2667.2.025	25	41	44	24	39.8
2667.2.032	32	51	56	31	41.3
2667.2.038	38	61	66	36	45
2667.2.040	40	61	66	36	45

Mounting example

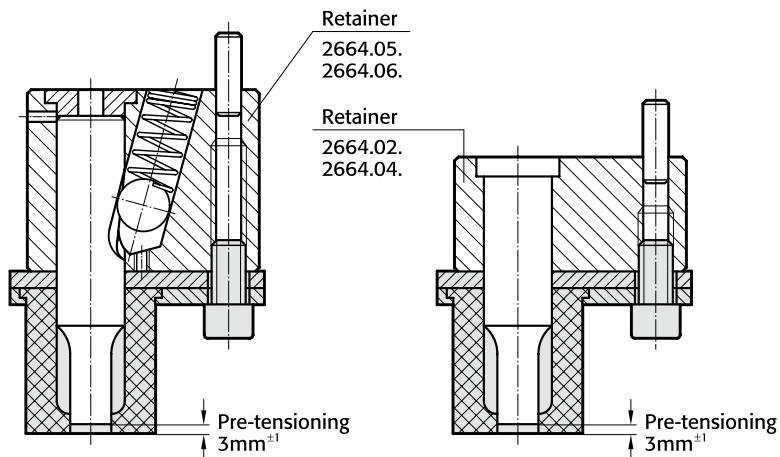

ELASTOMER STRIPPER



Mounting example

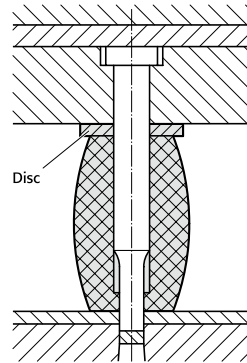

243.7.

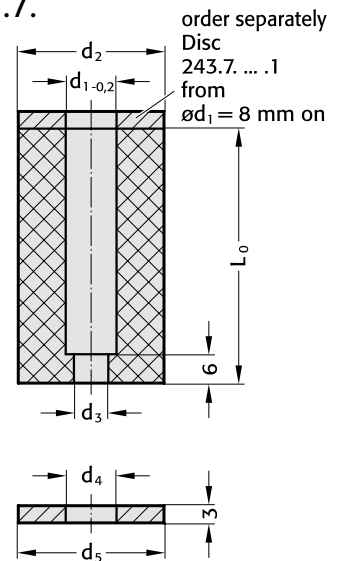

Description:

Repairs, sharpening and modifications on dies equipped with elastomer strippers do not necessitate the dismantling of a stripper plate, thus becoming very expedient.

Any marring of delicate part surfaces is precluded. This makes elastomer strippers ideal for all painted, anodized, plastic-coated and polished parts. FIBROFLEX® Elastomer Strippers are resistant against oils and greases.

Material:

FIBROFLEX®
Hardness: 95 Shore A

Execution:

Stock lengths: 39, 47, 56 mm.
Other lengths on request (max. 56 mm)!

Application:

Especially in large dies, where the use of elastomer strippers does away with the need of huge stripper plates.

Mounting:

Push stripper over punch, where it will stay put on account of its elasticity.

No other form of retention will be required.

A single press stroke will then pierce a hole through the bottom portion of the stripper that matches the punch shape exactly.

243.7. Elastomer Stripper

d ₁	d ₂	d ₃	L ₀	39	47	56
4	17	1.6		●	●	●
5	17	1.6		●	●	●
6	19	1.6		●	●	●
6.3	19	1.6		●	●	●
8	21	3		●	●	●
10	23	3		●	●	●
12.5	26	3		●	●	●
13	26	3		●	●	●
16	30	3		●	●	●
20	38	3		●	●	●
25	50	3		●	●	●
32	55	3		●	●	●
38	60	3		●	●	●
40	63	3		●	●	●

Ordering Code (example):

Elastomer Stripper	=	243.7.
Inner diameter d ₁	13 mm =	130.
Length L ₀	39 mm =	039
Order No	=	243.7. 130.039

WASHER

243.7. .1

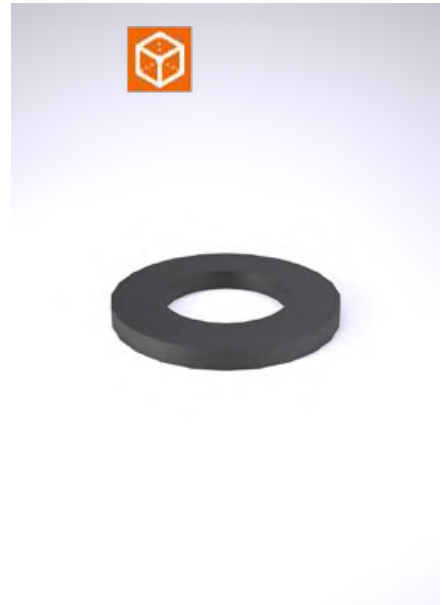
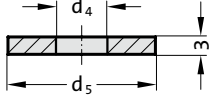

Material:

Steel

243.7. .1 Washer

Order No	d_4	d_5
243.7.085.1	8.5	21
243.7.105.1	10.5	23
243.7.130.1	13	26
243.7.135.1	13.5	26
243.7.165.1	16.5	30
243.7.205.1	20.5	38
243.7.255.1	25.5	50
243.7.325.1	32.5	55
243.7.385.1	38.5	60
243.7.405.1	40.5	63

POLY STRIP STRIPPER UNIT - ORDER EXAMPLES

Note: See table for standard dimensions
Special dimensions to order

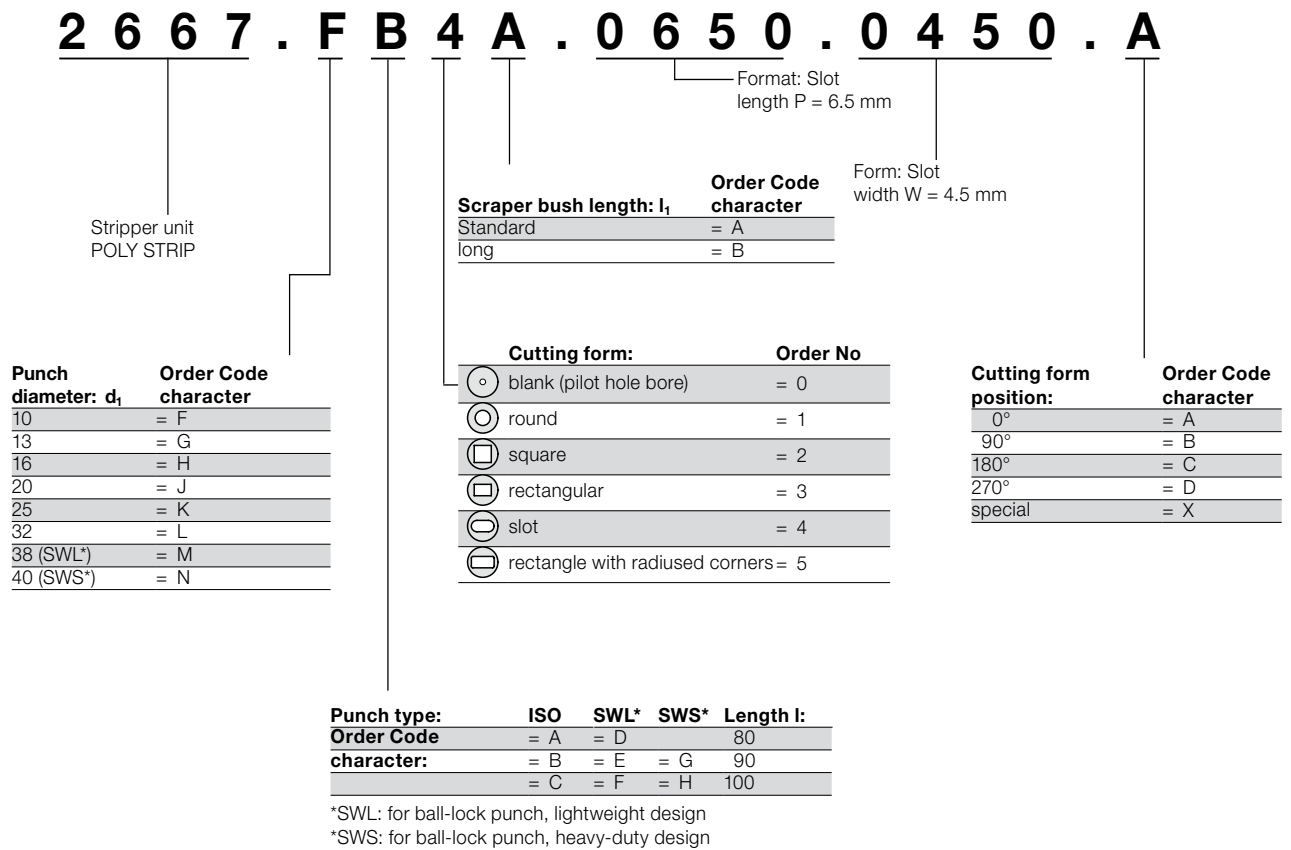

Ordering Code (example):

2 6 6 7 . F B 4 A . 0 6 5 0 . 0 4 5 0 . A

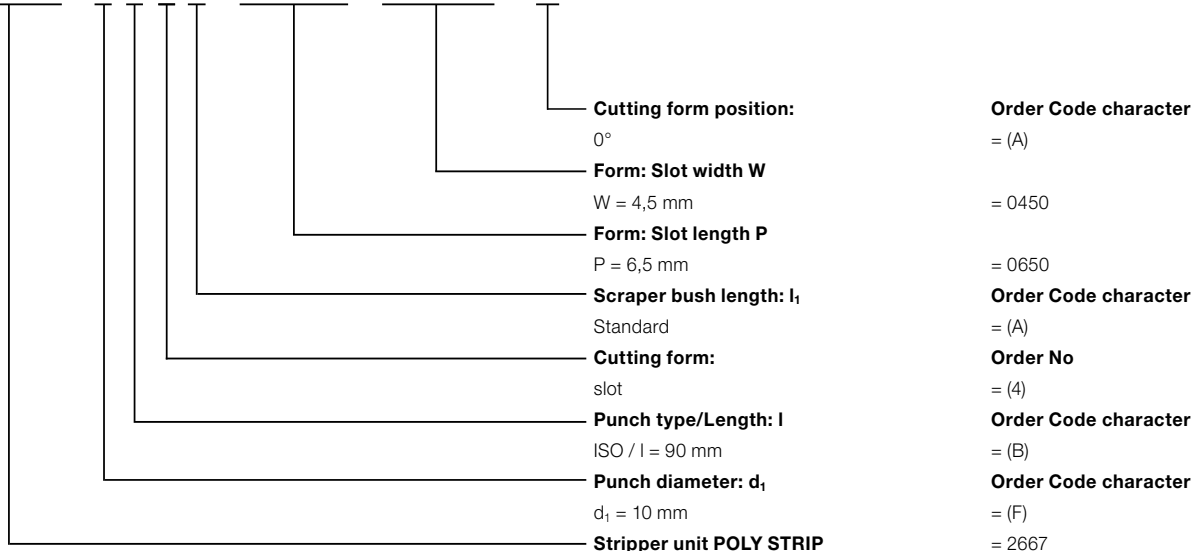

POLY STRIP STRIPPER UNIT, WITH START BOREHOLE, FOR ISO 8020 PUNCH

2667.□□0□.

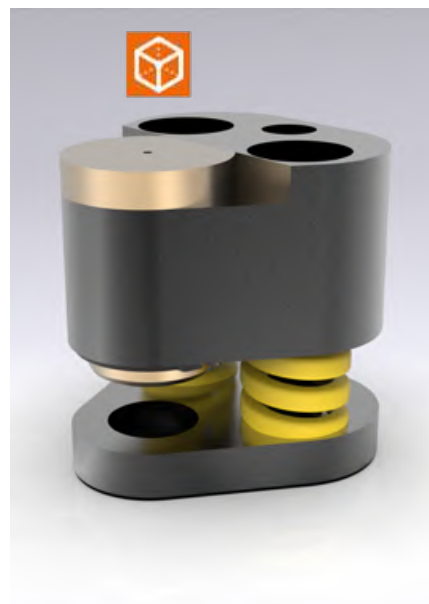
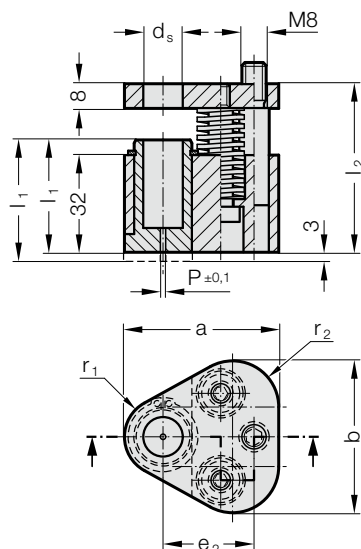

2667.xx0x. POLY STRIP stripper unit, with start borehole, for ISO 8020 punch

d _s / (Order Code character)	P	a	b	e ₂	r ₁	r ₂	l / (Order Code character)	80 (A)	90 (B)	100 (C)	l ₁ / (Order Code character)	37 (A)	40 (B)
							l ₂	55.5	65.5	75.5	S _(max)		
10 / (F)	1.5	44.5	43.7	26.925	9.5	12		●	●	●		●	●
13 / (G)	1.5	50.8	50	29.97	12.7	15.2		●	●	●		●	●
16 / (H)	1.5	54	53.2	31.75	14.3	16.8		●	●	●		●	●
20 / (J)	1.5	60.3	59.5	33.53	17.5	20		●	●	●		●	●
25 / (K)	1.5	69.9	69.1	40.64	22.2	24.7		●	●	●		●	●
32 / (L)	1.5	69.9	69.1	40.64	22.2	24.7		●	●	●		●	●

d _s / (Order Code character)	Punch length l	80	80	90	90	100	100
	Scraper bush l ₁	37	40	37	40	37	40
	Stripping force, max [N]	1022	884	1280	810	786	1098
10 / (F)		1022	884	1280	810	786	1098
13 / (G)		2856	1668	3128	1282	1920	2688
16 / (H)		5049	2714	5124	2180	3120	4368
20 / (J)		5049	2714	5124	2180	3120	4368
25 / (K)		5049	2714	5124	2180	3120	4368
32 / (L)		5049	2714	5124	2180	3120	4368

Ordering Code (example):

2667.FC0A.A

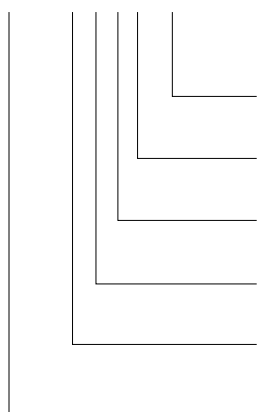

Cutting form position:

0°

Scraper bush length: l₁

Standard

Cutting form:

Start borehole

Punch type/length: l

ISO / l = 100 mm

Punch diameter: d_i

d_i = 10 mm

Stripper unit
POLY STRIP

Order Code character

= (A)

Order Code character

= (A)

Order No

= (0)

Order Code character

= (C)

Order Code character

= (F)

= 2667

Description:

The stripper unit is suitable for use with exterior skin panels.

Use with triangular mounting plate, for punch ISO 8020 2664.02./2664.04.

Material:

Scraper bush: CuZn25Al5 (no. 2.0598)

Scraper plate: 40CrMnMoS8-6 (no. 1.2312)

Pressure plate: 40CrMnMoS8-6 (no. 1.2312)

Note:

The stripper unit is available in 2 variants: Standard (A) and Long (B).

Long variant of the stripper unit with 3 mm projecting edge suitable for retrofitting a contour.

POLY STRIP STRIPPER UNIT, ROUND, FOR ISO 8020 PUNCH

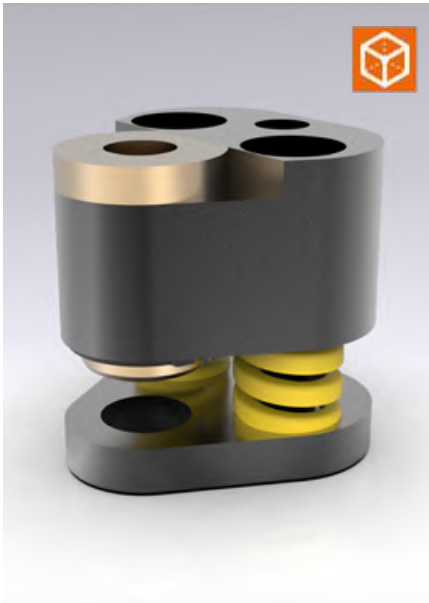

2667.□□1□.

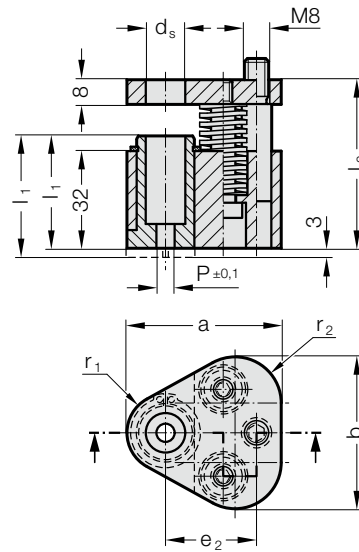

2□11. d_s 2664.04.

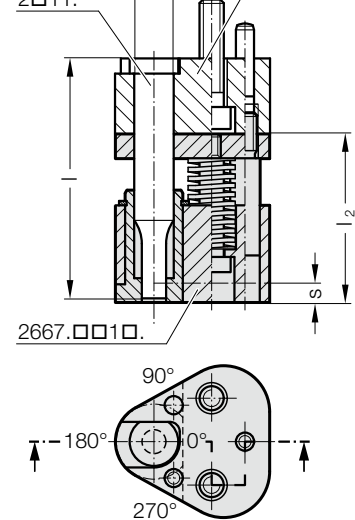

2667.xx1x. POLY STRIP stripper unit, round, for ISO 8020 punch

d _s / (Order Code character)	P	a	b	e ₂	r ₁	r ₂	l / (Order Code character)	80 (A)	90 (B)	100 (C)	l ₁ / (Order Code character)	37 (A)	40 (B)
							l ₂	55.5	65.5	75.5	s _(max)	6.5	9.5
10 / (F)	4 - 9,9	44.5	43.7	26.925	9.5	12		●	●	●		●	●
13 / (G)	5 - 12,9	50.8	50	29.97	12.7	15.2		●	●	●		●	●
16 / (H)	8 - 15,9	54	53.2	31.75	14.3	16.8		●	●	●		●	●
20 / (J)	12 9,9	60.3	59.5	33.53	17.5	20		●	●	●		●	●
25 / (K)	16,5 4,9	69.9	69.1	40.64	22.2	24.7		●	●	●		●	●
32 / (L)	20 1,9	69.9	69.1	40.64	22.2	24.7		●	●	●		●	●

d _s / (Order Code character)	Punch length l	80	80	90	90	100	100
	Scraper bush l ₁	37	40	37	40	37	40
	Stripping force, max [N]	1022	884	1280	810	786	1098
10 / (F)		1022	884	1280	810	786	1098
13 / (G)		1022	884	1280	810	786	1098
16 / (H)		2856	1668	3128	1282	1920	2688
20 / (J)		5049	2714	5124	2180	3120	4368
25 / (K)		5049	2714	5124	2180	3120	4368
32 / (L)		5049	2714	5124	2180	3120	4368

Description:

The stripper unit is suitable for use with exterior skin panels.

Use with triangular mounting plate, for punch ISO 8020 2664.02./2664.04.

Material:

Scraper bush: CuZn25Al5 (no. 2.0598)
Scraper plate: 40CrMnMoS8-6 (no. 1.2312)
Pressure plate: 40CrMnMoS8-6 (no. 1.2312)

Note:

The stripper unit is available in 2 variants: Standard (A) and Long (B).

Long variant of the stripper unit with 3 mm projecting edge suitable for retrofitting a contour.

Choose the position of the cutting form in the scraper bush in accordance with the position of the installed punch in the mounting plate.

Ordering Code (example):

2667.FC1A.0400.A

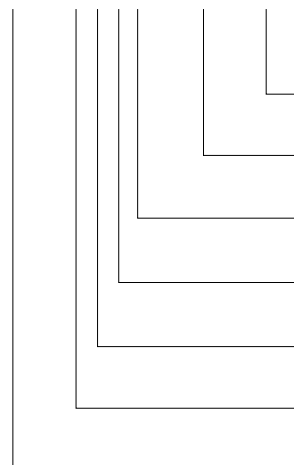

Cutting form position:

0°

Shape: round

P = ø4,0 mm

Scraper bush length: l₁

Standard

Cutting form:

round

Punch type/length: l

ISO / l = 100 mm

Punch diameter: d₁

d₁ = 10 mm

Stripper unit POLY STRIP

Order Code character

= (A)

= 0400

Order Code character

= (A)

Order No

= (1)

Order Code character

= (C)

Order Code character

= (F)

= 2667

POLY STRIP STRIPPER UNIT, SQUARE, FOR ISO 8020 PUNCH

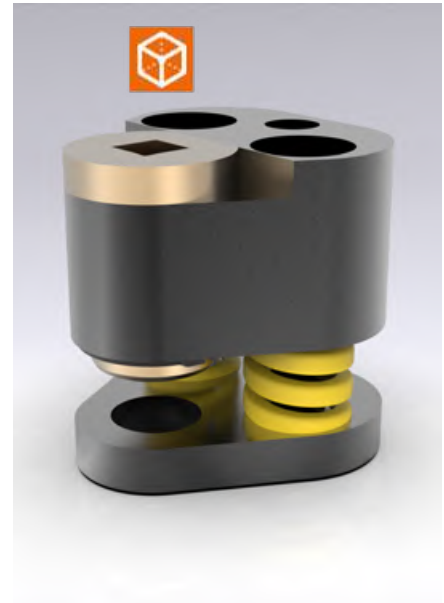
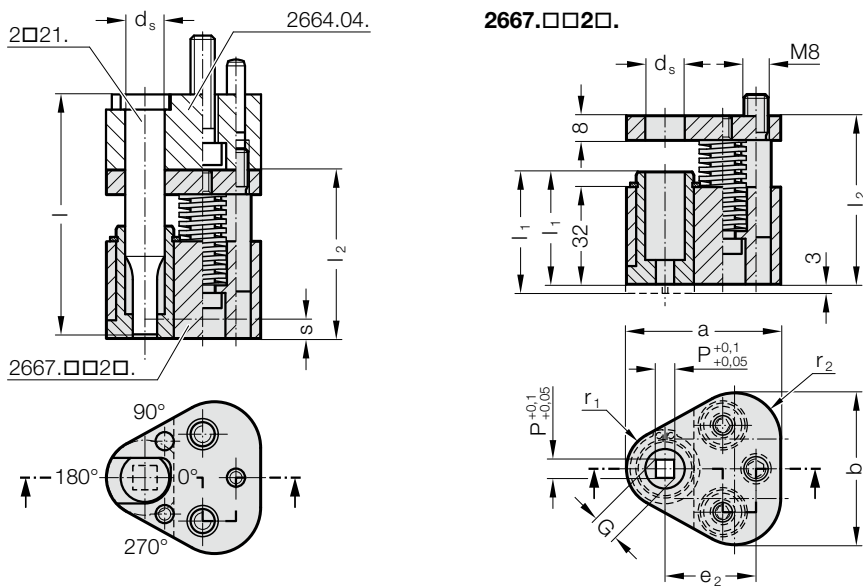

2667.xx2x. POLY STRIP stripper unit, square, for ISO 8020 punch

d_s / (Order Code character)	P_{min}	G_{max}	a	b	e_2	r_1	r_2	l (Order Code character)	80 (A)	90 (B)	100 (C)	l_1 (Order Code character)	37 (A)	40 (B)
								l_2	55.5	65.5	75.5	$S_{(max)}$	6.5	9.5
10 / (F)	3.5	9.9	44.5	43.7	26.925	9.5	12		●	●	●		●	●
13 / (G)	4.5	12.9	50.8	50	29.97	12.7	15.2		●	●	●		●	●
16 / (H)	6	15.9	54	53.2	31.75	14.3	16.8		●	●	●		●	●
20 / (J)	8	19.9	60.3	59.5	33.53	17.5	20		●	●	●		●	●
25 / (K)	10	24.9	69.9	69.1	40.64	22.2	24.7		●	●	●		●	●
32 / (L)	10	31.9	69.9	69.1	40.64	22.2	24.7		●	●	●		●	●

d_s / (Order Code character)	Punch length l	80	80	90	90	100	100
	Scraper bush l_1	37	40	37	40	37	40
	Stripping force, max [N]	1022	884	1280	810	786	1098
10 / (F)		1022	884	1280	810	786	1098
13 / (G)		1022	884	1280	810	786	1098
16 / (H)		2856	1668	3128	1282	1920	2688
20 / (J)		5049	2714	5124	2180	3120	4368
25 / (K)		5049	2714	5124	2180	3120	4368
32 / (L)		5049	2714	5124	2180	3120	4368

Ordering Code (example):

2667.FB2A.0400.A

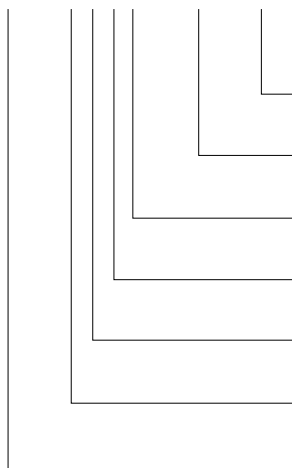

Cutting form position:

0°

Form: Square length P

P = 4,0 mm

Scraper bush length: l_1

Standard

Cutting form:

square

Punch type/length: l

ISO / l = 90 mm

Punch diameter: d_1

d_1 = 10 mm

Stripper unit POLY STRIP

Order Code character

= (A)

= 0400

Order Code character

= (A)

Order No

= (2)

Order Code character

= (B)

Order Code character

= (F)

= 2667

Description:

The stripper unit is suitable for use with exterior skin panels.

Use with triangular mounting plate, for punch ISO 8020 2664.04.

Material:

Scraper bush: CuZn25Al5 (no. 2.0598)

Scraper plate: 40CrMnMoS8-6 (no. 1.2312)

Pressure plate: 40CrMnMoS8-6 (no. 1.2312)

Note:

The stripper unit is available in 2 variants: Standard (A) and Long (B).

Long variant of the stripper unit with 3 mm projecting edge suitable for retrofitting a contour.

Choose the position of the cutting form in the scraper bush in accordance with the position of the installed punch in the mounting plate.

POLY STRIP STRIPPER UNIT, RECTANGLE, FOR ISO 8020 PUNCH

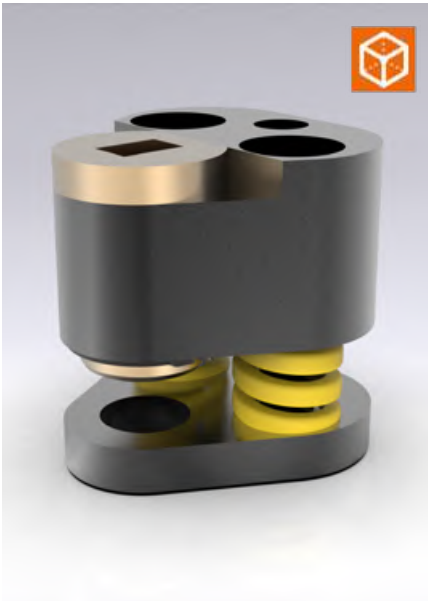

2667.□□3□.

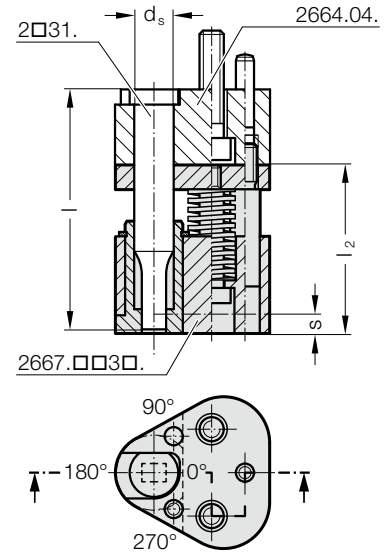
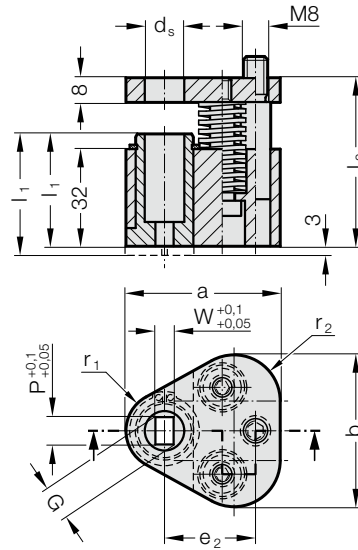

2667.xx3x. POLY STRIP stripper unit, rectangle, for ISO 8020 punch

d_s / (Order Code character)	W_{min}	G_{max}	a	b	e_2	r_1	r_2	l (Order Code character)	80 (A)	90 (B)	100 (C)	l_1 (Order Code character)	37 (A)	40 (B)
								l_2	55.5	65.5	75.5	$S_{(max)}$	6.5	9.5
10 / (F)	3.5	9.9	44.5	43.7	26.925	9.5	12		●	●	●		●	●
13 / (G)	4.5	12.9	50.8	50	29.97	12.7	15.2		●	●	●		●	●
16 / (H)	6	15.9	54	53.2	31.75	14.3	16.8		●	●	●		●	●
20 / (J)	8	19.9	60.3	59.5	33.53	17.5	20		●	●	●		●	●
25 / (K)	10	24.9	69.9	69.1	40.64	22.2	24.7		●	●	●		●	●
32 / (L)	10	31.9	69.9	69.1	40.64	22.2	24.7		●	●	●		●	●

d_s / (Order Code character)	Punch length l	80	80	90	90	100	100
	Scraper bush l_1	37	40	37	40	37	40
	Stripping force, max [N]	1022	884	1280	810	786	1098
10 / (F)		1022	884	1280	810	786	1098
13 / (G)		1022	884	1280	810	786	1098
16 / (H)		2856	1668	3128	1282	1920	2688
20 / (J)		5049	2714	5124	2180	3120	4368
25 / (K)		5049	2714	5124	2180	3120	4368
32 / (L)		5049	2714	5124	2180	3120	4368

Description:

The stripper unit is suitable for use with exterior skin panels.

Use with triangular mounting plate, for punch ISO 8020 2664.04.

Material:

Scraper bush: CuZn25Al5 (no. 2.0598)
Scraper plate: 40CrMnMoS8-6 (no. 1.2312)
Pressure plate: 40CrMnMoS8-6 (no. 1.2312)

Note:

The stripper unit is available in 2 variants: Standard (A) and Long (B).

Long variant of the stripper unit with 3 mm projecting edge suitable for retrofitting a contour.

Choose the position of the cutting form in the scraper bush in accordance with the position of the installed punch in the mounting plate.

Ordering Code (example):

2667.FB3A.0800.0500.A

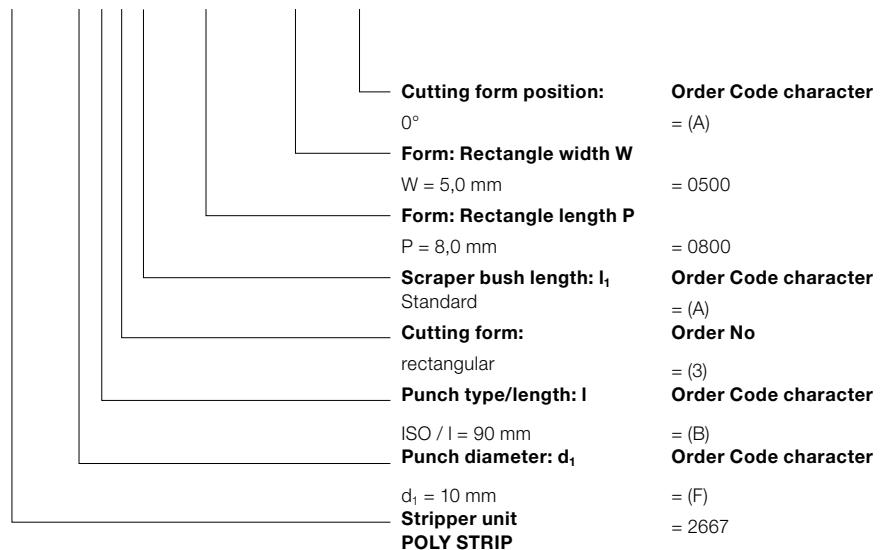

POLY STRIP STRIPPER UNIT, SLOT, FOR ISO 8020 PUNCH

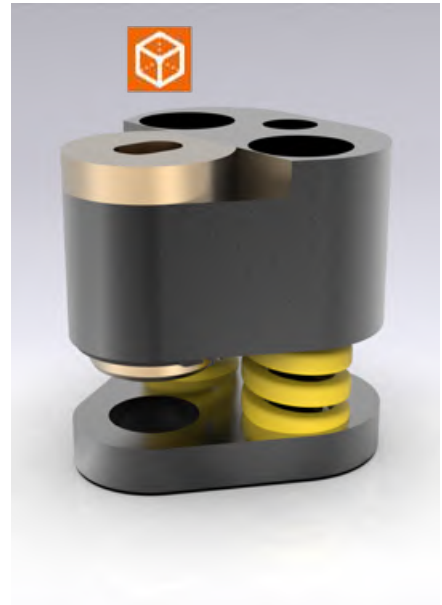
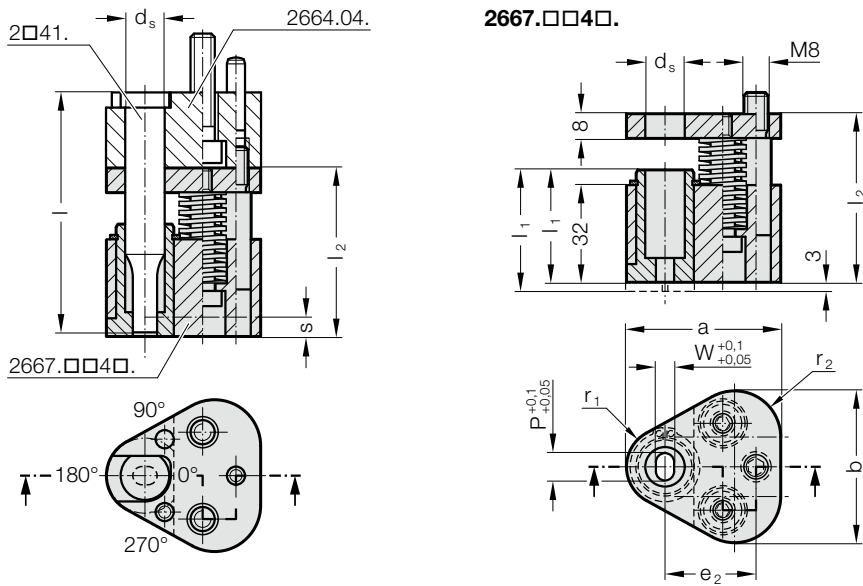

2667.xx4x. POLY STRIP stripper unit, slot, for ISO 8020 punch

d_s / (Order Code character)	W_{min}	G_{max}	a	b	e_2	r_1	r_2	l (Order Code character)	80 (A)	90 (B)	100 (C)	l_1 (Order Code character)	37 (A)	40 (B)
								l_2	55.5	65.5	75.5	$s_{(max)}$	6.5	9.5
10 / (F)	3.5	9.9	44.5	43.7	26.925	9.5	12		●	●	●		●	●
13 / (G)	4.5	12.9	50.8	50	29.97	12.7	15.2		●	●	●		●	●
16 / (H)	6	15.9	54	53.2	31.75	14.3	16.8		●	●	●		●	●
20 / (J)	8	19.9	60.3	59.5	33.53	17.5	20		●	●	●		●	●
25 / (K)	10	24.9	69.9	69.1	40.64	22.2	24.7		●	●	●		●	●
32 / (L)	10	31.9	69.9	69.1	40.64	22.2	24.7		●	●	●		●	●

d_s / (Order Code character)	Punch length l	80	80	90	90	100	100
	Scraper bush l_1	37	40	37	40	37	40
	Stripping force, max [N]	1022	884	1280	810	786	1098
10 / (F)		1022	884	1280	810	786	1098
13 / (G)		1022	884	1280	810	786	1098
16 / (H)		2856	1668	3128	1282	1920	2688
20 / (J)		5049	2714	5124	2180	3120	4368
25 / (K)		5049	2714	5124	2180	3120	4368
32 / (L)		5049	2714	5124	2180	3120	4368

Ordering Code (example):

2667.FB4A.0800.0500.A

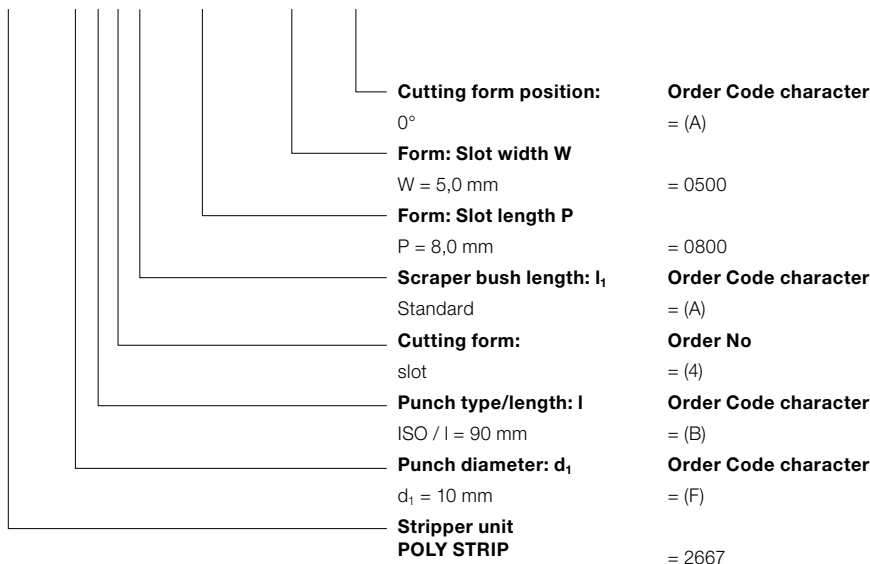

Description:

The stripper unit is suitable for use with exterior skin panels. Use with triangular mounting plate, for punch ISO 8020 2664.04.

Material:

Scraper bush: CuZn25Al5 (no. 2.0598)
Scraper plate: 40CrMnMoS8-6 (no. 1.2312)
Pressure plate: 40CrMnMoS8-6 (no. 1.2312)

Note:

The stripper unit is available in 2 variants: Standard (A) and Long (B). Long variant of the stripper unit with 3 mm projecting edge suitable for retrofitting a contour. Choose the position of the cutting form in the scraper bush in accordance with the position of the installed punch in the mounting plate.

POLY STRIP STRIPPER UNIT, RECTANGLE WITH RADIUS, FOR ISO 8020 PUNCH

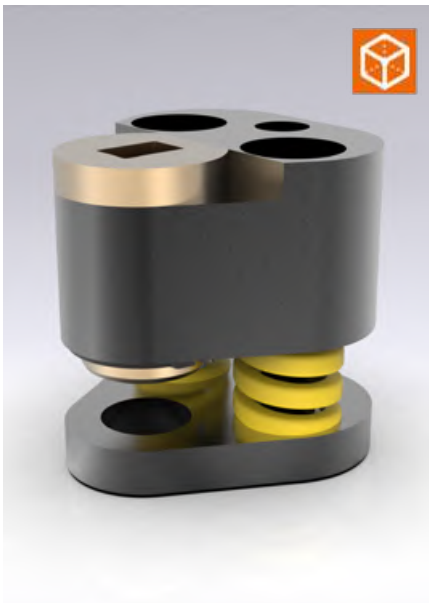

2667.□□5□.

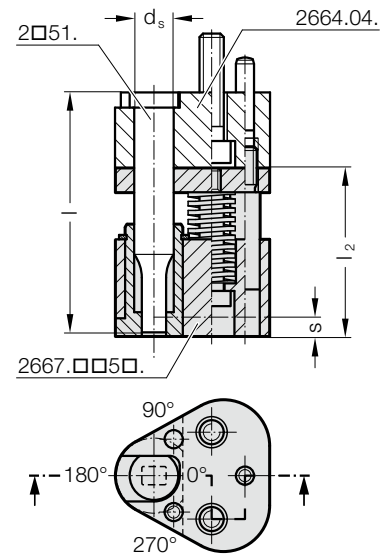
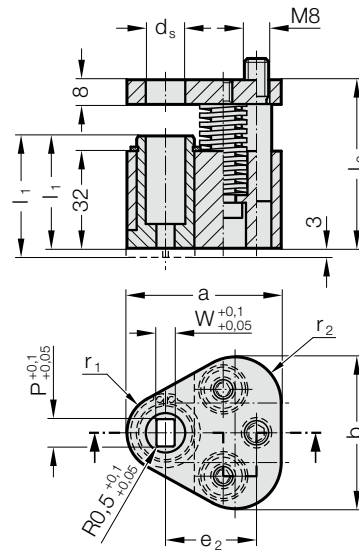

2667.xx5x. POLY STRIP stripper unit, rectangle with radius, for ISO 8020 punch

d_s / (Order Code character)	W_{min}	G_{max}	a	b	e_2	r_1	r_2	l (Order Code character)	80 (A)	90 (B)	100 (C)	l_1 (Order Code character)	37 (A)	40 (B)
								l_2	55.5	65.5	75.5	$S_{(max)}$	6.5	9.5
10 / (F)	3.5	9.9	44.5	43.7	26.925	9.5	12		●	●	●		●	●
13 / (G)	4.5	12.9	50.8	50	29.97	12.7	15.2		●	●	●		●	●
16 / (H)	6	15.9	54	53.2	31.75	14.3	16.8		●	●	●		●	●
20 / (J)	8	19.9	60.3	59.5	33.53	17.5	20		●	●	●		●	●
25 / (K)	10	24.9	69.9	69.1	40.64	22.2	24.7		●	●	●		●	●
32 / (L)	10	31.9	69.9	69.1	40.64	22.2	24.7		●	●	●		●	●

d_s / (Order Code character)	Punch length l	80	80	90	90	100	100
	Scraper bush l_1	37	40	37	40	37	40
	Stripping force, max [N]	1022	884	1280	810	786	1098
10 / (F)		1022	884	1280	810	786	1098
13 / (G)		1022	884	1280	810	786	1098
16 / (H)		2856	1668	3128	1282	1920	2688
20 / (J)		5049	2714	5124	2180	3120	4368
25 / (K)		5049	2714	5124	2180	3120	4368
32 / (L)		5049	2714	5124	2180	3120	4368

Description:

The stripper unit is suitable for use with exterior skin panels.

Use with triangular mounting plate, for punch ISO 8020 2664.04.

Material:

Scraper bush: CuZn25Al5 (no. 2.0598)

Scraper plate: 40CrMnMoS8-6 (no. 1.2312)

Pressure plate: 40CrMnMoS8-6 (no. 1.2312)

Note:

The stripper unit is available in 2 variants:

Standard (A) and Long (B).

Long variant of the stripper unit with 3 mm projecting edge suitable for retrofitting a contour.

Choose the position of the cutting form in the scraper bush in accordance with the position of the installed punch in the mounting plate.

Ordering Code (example):

2667.FB5A.0800.0500.A

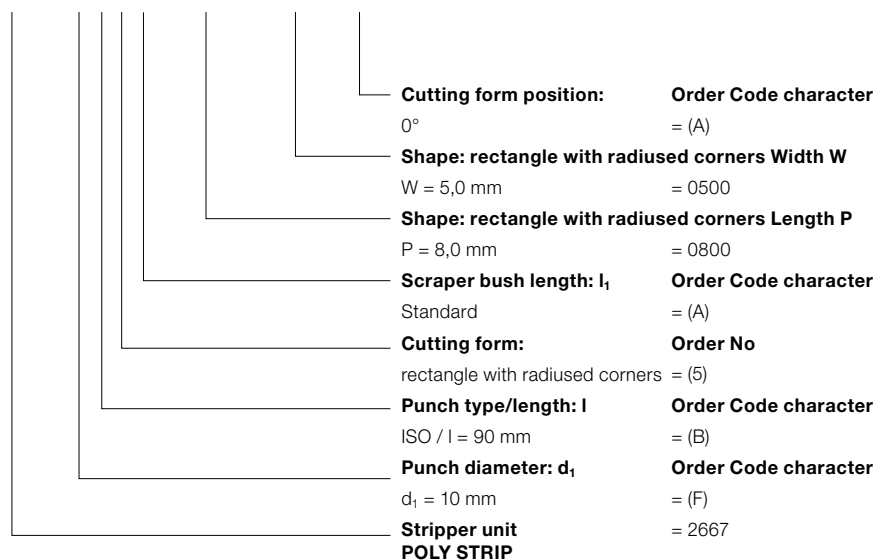

POLY STRIP STRIPPER UNIT, WITH START BOREHOLE, FOR BALL-LOCK PUNCH

2667.□□0□.

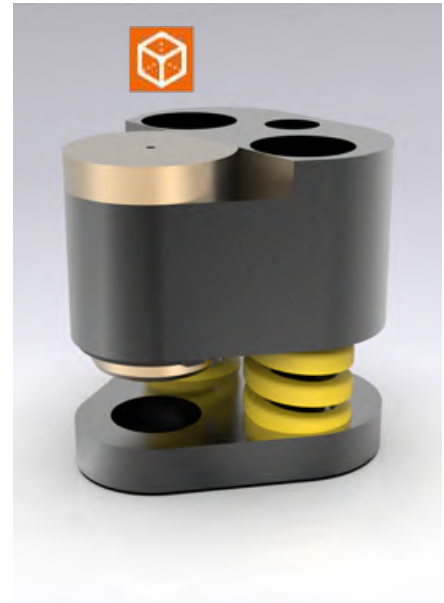
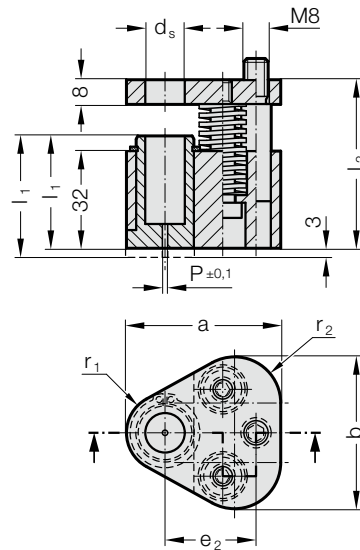

2667.xx0x. POLY STRIP stripper unit, with start borehole, for ball-lock punch

d _s / (Order Code character)	P	a	b	e ₂	r ₁	r ₂	Punch type					l ₁	37	40	
							l	SWL	SWL	SWS	SWL				SWS
							l ₂	(D)	(E)	(G)	(F)	(H)			
10 / (F)	1.5	44.5	43.7	26.925	9.5	12	55.5	80	90	90	100	100			
13 / (G)	1.5	50.8	50	29.97	12.7	15.2									
16 / (H)	1.5	54	53.2	31.75	14.3	16.8									
20 / (J)	1.5	60.3	59.5	33.53	17.5	20									
25 / (K)	1.5	69.9	69.1	40.64	22.2	24.7									
32 / (L)	1.5	69.9	69.1	40.64	22.2	24.7									
38 / (M)	1.5	77.4	76.6	43.99	26	28.5									
40 / (N)	1.5	77.4	76.6	43.99	26	28.5									

d _s / (Order Code character)	Punch type	Punch length l	Scraper bush l ₁	Stripping force, max [N]	SWL		SWL		SWS		SWS		
					080	080	090	090	100	100	090	090	100
10 / (F)				1022	884	1280	810	786	1098	1280	810	786	1098
13 / (G)				1022	884	1280	810	786	1098	1280	810	786	1098
16 / (H)				2856	1668	3128	1282	1920	2688	3128	1282	1920	2688
20 / (J)				5049	2714	5124	2180	3120	4368	5124	2180	3120	4368
25 / (K)				5049	2714	5124	2180	3120	4368	5124	2180	3120	4368
32 / (L)				5049	2714	5124	2180	3120	4368	5124	2180	3120	4368
38 / (M)				5049	2714	5124	2180	3120	4368				
40 / (N)										5124	2180	3120	4368

Ordering Code (example):

2667.FE0A.A

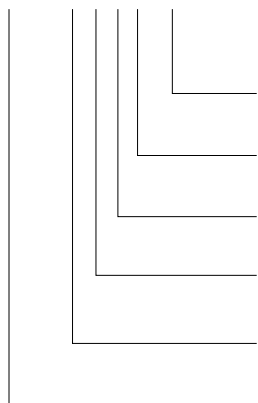

Cutting form position:

0°

Scraper bush length: l₁

Standard

Cutting form:

Start borehole

Punch type/length: l

SWL / l = 90 mm

Punch diameter: d₁

d₁ = 10 mm

Stripper unit
POLY STRIP

Order Code character

= (A)

Order Code character

= (A)

Order No

= (0)

Order Code character

= (E)

Order Code character

= (F)

= 2667

Description:

The brush cleaner unit is suitable for use with exterior skin panels.

Use with triangular mounting plate, for ball-lock punch 2664.05./06./10.

Material:

Scraper bush: CuZn25Al5 (no. 2.0598)

Scraper plate: 40CrMnMoS8-6 (no. 1.2312)

Pressure plate: 40CrMnMoS8-6 (no. 1.2312)

Note:

The stripper unit is available in 2 variants: Standard (A) and Long (B).

Long variant of the stripper unit with 3 mm projecting edge suitable for retrofitting a contour.

POLY STRIP STRIPPER UNIT, ROUND, FOR BALL-LOCK PUNCH

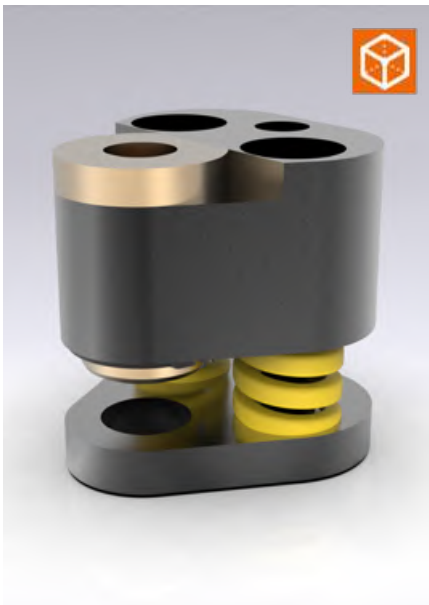

2667.□□1□.

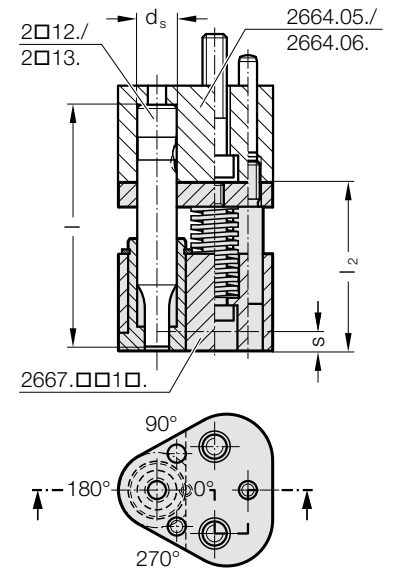
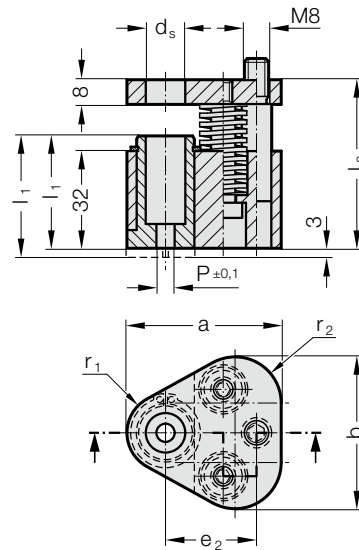

2667.xx1x. POLY STRIP stripper unit, round, for ball-lock punch

d _s / (Order Code character)	P	a	b	e ₂	r ₁	r ₂	Punch type					l ₁ S _(max)	37 (A)	40 (B)				
							l	SWL (D)	SWL (E)	SWS (G)	SWL (F)				SWS (H)			
10 / (F)	1,6 - 9,9	44.5	43.7	26.925	9.5	12	80	90	90	100	100	55.5	65.5	65.5	75.5	75.5	●	●
13 / (G)	5 - 12,9	50.8	50	29.97	12.7	15.2	●	●	●	●	●	●	●	●	●	●	●	●
16 / (H)	8 - 15,9	54	53.2	31.75	14.3	16.8	●	●	●	●	●	●	●	●	●	●	●	●
20 / (J)	12 - 19,9	60.3	59.5	33.53	17.5	20	●	●	●	●	●	●	●	●	●	●	●	●
25 / (K)	16 - 24,9	69.9	69.1	40.64	22.2	24.7	●	●	●	●	●	●	●	●	●	●	●	●
32 / (L)	24 - 31,9	69.9	69.1	40.64	22.2	24.7	●	●	●	●	●	●	●	●	●	●	●	●
38 / (M)	30	7,9	77.4	76	43.9	26	28.5	●	●	●	●	●	●	●	●	●	●	●
40 / (N)	30	9,9	77.4	76	43.9	26	28.5	●	●	●	●	●	●	●	●	●	●	●

d _s / (Order Code character)	Punch type	Punch length l	Scraper bush l ₁	Stripping force, max [N]	SWL / SWS													
					080	080	090	090	100	100	100	100	090	090	100	100		
10 / (F)			37	1022	884	1280	810	786	1098	1280	810	786	1098					
13 / (G)			37	1022	884	1280	810	786	1098	1280	810	786	1098					
16 / (H)			37	2856	1668	3128	1282	1920	2688	3128	1282	1920	2688					
20 / (J)			37	5049	2714	5124	2180	3120	4368	5124	2180	3120	4368					
25 / (K)			37	5049	2714	5124	2180	3120	4368	5124	2180	3120	4368					
32 / (L)			37	5049	2714	5124	2180	3120	4368	5124	2180	3120	4368					
38 / (M)			37	5049	2714	5124	2180	3120	4368									
40 / (N)			37							5124	2180	3120	4368					

Description:

The brush cleaner unit is suitable for use with exterior skin panels.
Use with triangular mounting plate, for ball-lock punch 2664.05./06./10.

Material:

Scraper bush: CuZn25Al5 (no. 2.0598)
Scraper plate: 40CrMnMoS8-6 (no. 1.2312)
Pressure plate: 40CrMnMoS8-6 (no. 1.2312)

Note:

The stripper unit is available in 2 variants: Standard (A) and Long (B).
Long variant of the stripper unit with 3 mm projecting edge suitable for retrofitting a contour.
Choose the position of the cutting form in the scraper bush in accordance with the position of the installed punch in the mounting plate.

Ordering Code (example):

2667.FE1A.0400.A

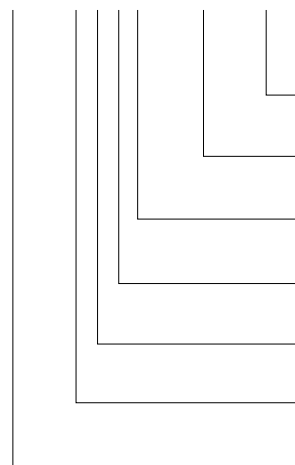

Cutting form position:
0° = (A)

Shape: round P
P = ø4,0 mm = 0400

Scraper bush length: l₁
Standard = (A)

Cutting form:
round = (1)

Punch type/length: l
SWL / l = 90 mm = (E)

Punch diameter: d₁
d₁ = 10 mm = (F)

Stripper unit
POLY STRIP = 2667

POLY STRIP STRIPPER UNIT, SQUARE, FOR BALL-LOCK PUNCH

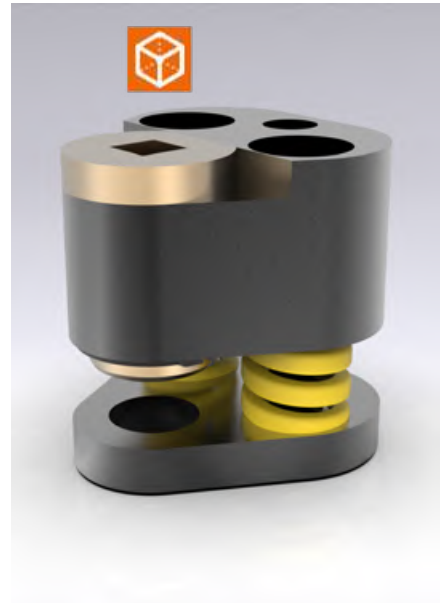
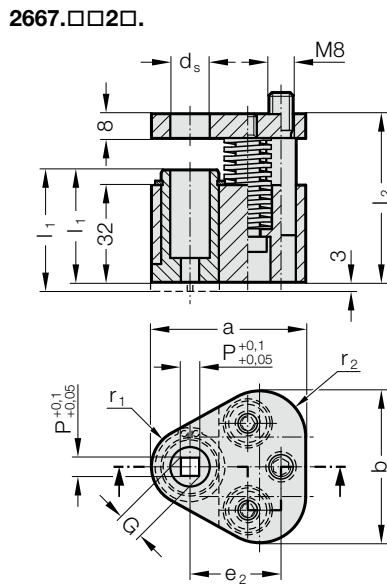
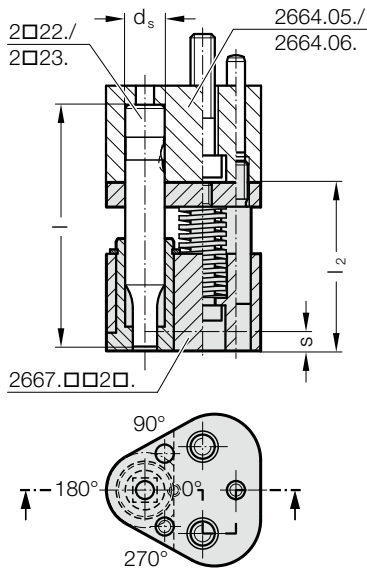

2667.xx2x. POLY STRIP stripper unit, square, for ball-lock punch

d _s / (Order Code character)	P _{min}	G _{max}	a	b	e ₂	r ₁	r ₂	Punch type l (Order Code character)	SWL	SWL	SWS	SWL	SWS	l ₁ (Order Code character)	37	40
									(D)	(E)	(G)	(F)	(H)		S _(max)	(A)
10 / (F)	1.6	9.9	44.5	43.7	26.925	9.5	12	l ₂	55.5	65.5	65.5	75.5	75.5		●	●
13 / (G)	4.5	12.9	50.8	50	29.97	12.7	15.2			●	●	●	●		●	●
16 / (H)	6	15.9	54	53.2	31.75	14.3	16.8			●	●	●	●		●	●
20 / (J)	8	19.9	60.3	59.5	33.53	17.5	20			●	●	●	●		●	●
25 / (K)	10	24.9	69.9	69.1	40.64	22.2	24.7			●	●	●	●		●	●
32 / (L)	12.5	31.9	69.9	69.1	40.64	22.2	24.7			●	●	●	●		●	●
38 / (M)	14	37.9	77.4	76	43.9	26	28.5		●	●		●			●	●
40 / (N)	14	39.9	77.4	76	43.9	26	28.5				●		●		●	●

d _s / (Order Code character)	Punch type Punch length l Scraper bush l ₁	Stripping force, max [N]	SWL	SWL	SWL	SWL	SWL	SWL	SWS	SWS	SWS	SWS
			080	080	090	090	100	100	090	090	100	100
10 / (F)	37	1022	884	1280	810	786	1098	1280	810	786	1098	1098
13 / (G)	40	1022	884	1280	810	786	1098	1280	810	786	1098	1098
16 / (H)	37	2856	1668	3128	1282	1920	2688	3128	1282	1920	2688	2688
20 / (J)	40	5049	2714	5124	2180	3120	4368	5124	2180	3120	4368	4368
25 / (K)	40	5049	2714	5124	2180	3120	4368	5124	2180	3120	4368	4368
32 / (L)	40	5049	2714	5124	2180	3120	4368	5124	2180	3120	4368	4368
38 / (M)	40	5049	2714	5124	2180	3120	4368					
40 / (N)	40							5124	2180	3120	4368	

Ordering Code (example):

2667.FE2A.0400.A

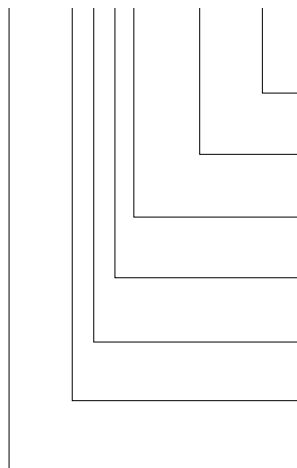

Cutting form position: 0°	Order Code character = (A)
Form: Square length P P = 4,0 mm	= 0400
Scraper bush length: l₁ Standard	Order Code character = (A)
Cutting form: square	Order No = (2)
Punch type/length: l SWL / l = 90 mm	Order Code character = (E)
Punch diameter: d₁ d ₁ = 10 mm	Order Code character = (F)
Stripper unit POLY STRIP	= 2667

Description:

The brush cleaner unit is suitable for use with exterior skin panels.
Use with triangular mounting plate, for ball-lock punch 2664.05./06./10.

Material:

Scraper bush: CuZn25Al5 (no. 2.0598)
Scraper plate: 40CrMnMoS8-6 (no. 1.2312)
Pressure plate: 40CrMnMoS8-6 (no. 1.2312)

Note:

The stripper unit is available in 2 variants: Standard (A) and Long (B).
Long variant of the stripper unit with 3 mm projecting edge suitable for retrofitting a contour.
Choose the position of the cutting form in the scraper bush in accordance with the position of the installed punch in the mounting plate.

POLY STRIP STRIPPER UNIT, RECTANGLE, FOR BALL-LOCK PUNCH

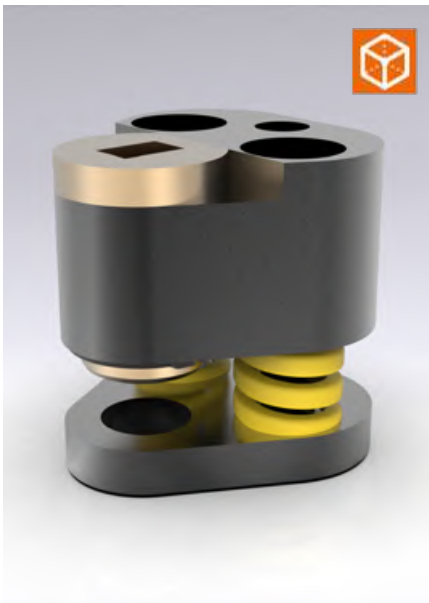

2667.□□3□.

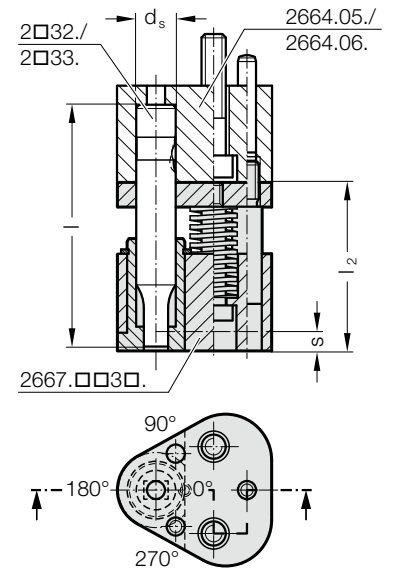
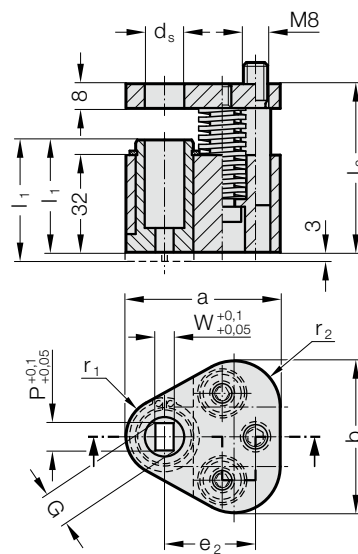

2667.xx3x. POLY STRIP stripper unit, rectangle, for ball-lock punch

d _s / (Order Code character)	W _{min}	G _{max}	a	b	e ₂	r ₁	r ₂	Punch type l ₂ (Order Code character)	SWL	SWL	SWS	SWL	SWS	l ₁ (Order Code character) S _(max)	37	40
									(D)	(E)	(G)	(F)	(H)		(A)	(B)
10 / (F)	1.6	9.9	44.5	43.7	26.925	9.5	12		80	90	90	100	100			
13 / (G)	4.5	12.9	50.8	50	29.97	12.7	15.2									
16 / (H)	6	15.9	54	53.2	31.75	14.3	16.8									
20 / (J)	8	19.9	60.3	59.5	33.53	17.5	20									
25 / (K)	10	24.9	69.9	69.1	40.64	22.2	24.7									
32 / (L)	12.5	31.9	69.9	69.1	40.64	22.2	24.7									
38 / (M)	14	37.9	77.4	76	43.9	26	28.5									
40 / (N)	14	39.9	77.4	76	43.9	26	28.5									

d _s / (Order Code character)	Punch type Punch length l ₁ Scraper bush l ₁	SWL	SWL	SWL	SWL	SWL	SWL	SWS	SWS	SWS	SWS
		080	080	090	090	100	100	090	090	100	100
10 / (F)	Stripping force, max [N]	1022	884	1280	810	786	1098	1280	810	786	1098
13 / (G)		1022	884	1280	810	786	1098	1280	810	786	1098
16 / (H)		2856	1668	3128	1282	1920	2688	3128	1282	1920	2688
20 / (J)		5049	2714	5124	2180	3120	4368	5124	2180	3120	4368
25 / (K)		5049	2714	5124	2180	3120	4368	5124	2180	3120	4368
32 / (L)		5049	2714	5124	2180	3120	4368	5124	2180	3120	4368
38 / (M)		5049	2714	5124	2180	3120	4368				
40 / (N)								5124	2180	3120	4368

Description:

The brush cleaner unit is suitable for use with exterior skin panels.
Use with triangular mounting plate, for ball-lock punch 2664.05./06./10.

Material:

Scraper bush: CuZn25Al5 (no. 2.0598)
Scraper plate: 40CrMnMoS8-6 (no. 1.2312)
Pressure plate: 40CrMnMoS8-6 (no. 1.2312)

Note:

The stripper unit is available in 2 variants: Standard (A) and Long (B).
Long variant of the stripper unit with 3 mm projecting edge suitable for retrofitting a contour.
Choose the position of the cutting form in the scraper bush in accordance with the position of the installed punch in the mounting plate.

Ordering Code (example):

2667.FE3A.0800.0500.A

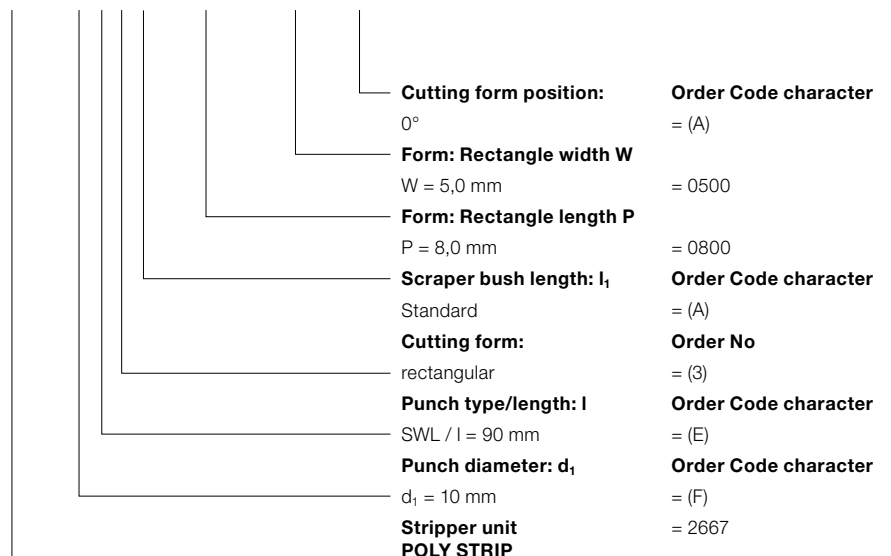

POLY STRIP STRIPPER UNIT, SLOT, FOR BALL-LOCK PUNCH

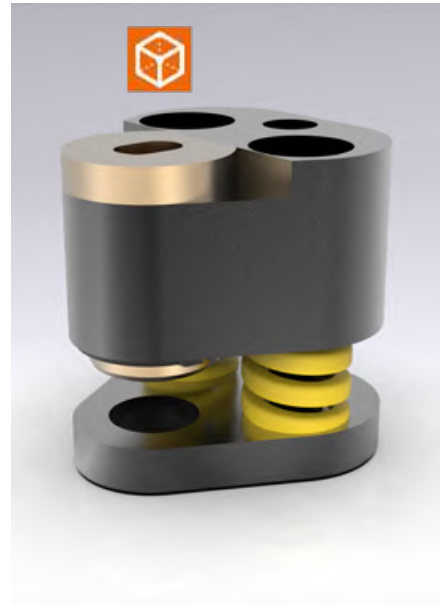
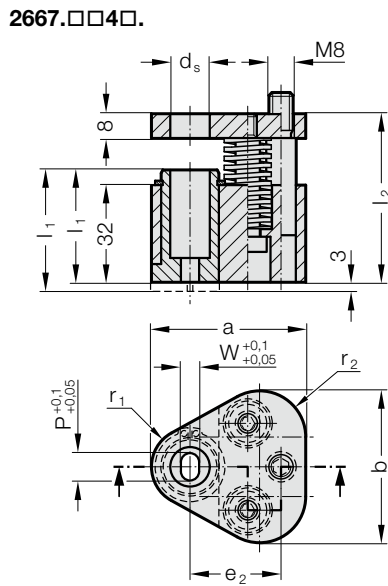
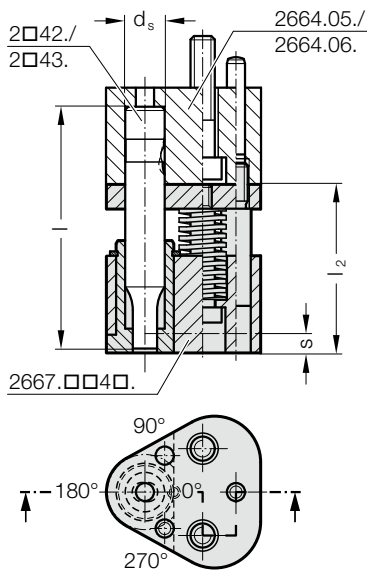

2667.xx4x. POLY STRIP stripper unit, slot, for ball-lock punch

d _s / (Order Code character)	W _{min}	G _{max}	a	b	e ₂	r ₁	r ₂	Punch type l (Order Code character)	SWL (D)	SWL (E)	SWS (G)	SWL (F)	SWS (H)	l ₁ S _(max)	37 40		
															(A)	(B)	
10 / (F)	1.6	9.9	44.5	43.7	26.925	9.5	12	l ₂	55.5	65.5	65.5	75.5	75.5			●	●
13 / (G)	4.5	12.9	50.8	50	29.97	12.7	15.2			●	●	●	●			●	●
16 / (H)	6	15.9	54	53.2	31.75	14.3	16.8			●	●	●	●			●	●
20 / (J)	8	19.9	60.3	59.5	33.53	17.5	20			●	●	●	●			●	●
25 / (K)	10	24.9	69.9	69.1	40.64	22.2	24.7			●	●	●	●			●	●
32 / (L)	12.5	31.9	69.9	69.1	40.64	22.2	24.7			●	●	●	●			●	●
38 / (M)	14	37.9	77.4	76	43.9	26	28.5		●	●		●				●	●
40 / (N)	14	39.9	77.4	76	43.9	26	28.5				●		●			●	●

d _s / (Order Code character)	Punch type Punch length l Scraper bush l ₁	Stripping force, max [N]	SWL	SWL	SWL	SWL	SWL	SWL	SWS	SWS	SWS	SWS
			080	080	090	090	100	100	090	090	100	100
10 / (F)		1022	884	1280	810	786	1098	1280	810	786	1098	
13 / (G)		1022	884	1280	810	786	1098	1280	810	786	1098	
16 / (H)		2856	1668	3128	1282	1920	2688	3128	1282	1920	2688	
20 / (J)		5049	2714	5124	2180	3120	4368	5124	2180	3120	4368	
25 / (K)		5049	2714	5124	2180	3120	4368	5124	2180	3120	4368	
32 / (L)		5049	2714	5124	2180	3120	4368	5124	2180	3120	4368	
38 / (M)		5049	2714	5124	2180	3120	4368					
40 / (N)									5124	2180	3120	4368

Ordering Code (example):

2667.FE4A.0800.0500.A

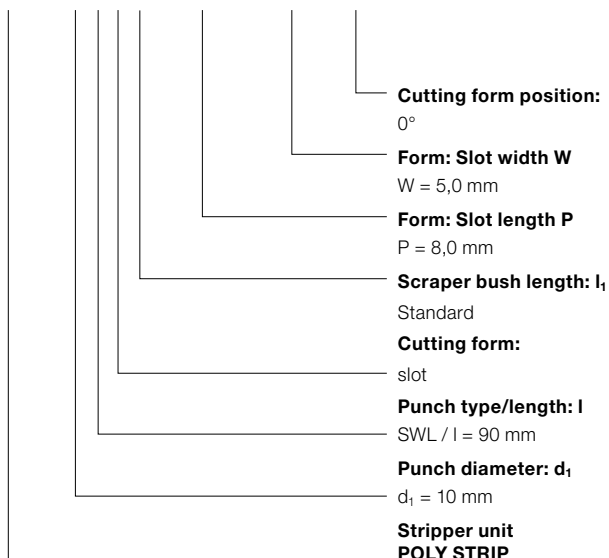

Cutting form position:
0°
Order Code character
= (A)

Form: Slot width W
W = 5,0 mm
Order Code character
= 0500

Form: Slot length P
P = 8,0 mm
Order Code character
= 0800

Scraper bush length: l₁
Standard
Order Code character
= (A)

Cutting form:
slot
Order No
= (4)

Punch type/length: l
SWL / l = 90 mm
Order Code character
= (E)

Punch diameter: d₁
d₁ = 10 mm
Order Code character
= (F)

Stripper unit
POLY STRIP
Order Code character
= 2667

Description:

The brush cleaner unit is suitable for use with exterior skin panels.
Use with triangular mounting plate, for ball-lock punch 2664.05./06./10.

Material:

Scraper bush: CuZn25Al5 (no. 2.0598)
Scraper plate: 40CrMnMoS8-6 (no. 1.2312)
Pressure plate: 40CrMnMoS8-6 (no. 1.2312)

Note:

The stripper unit is available in 2 variants: Standard (A) and Long (B).
Long variant of the stripper unit with 3 mm projecting edge suitable for retrofitting a contour.
Choose the position of the cutting form in the scraper bush in accordance with the position of the installed punch in the mounting plate.

POLY STRIP STRIPPER UNIT, SQUARE WITH RADIUS, FOR BALL-LOCK PUNCH

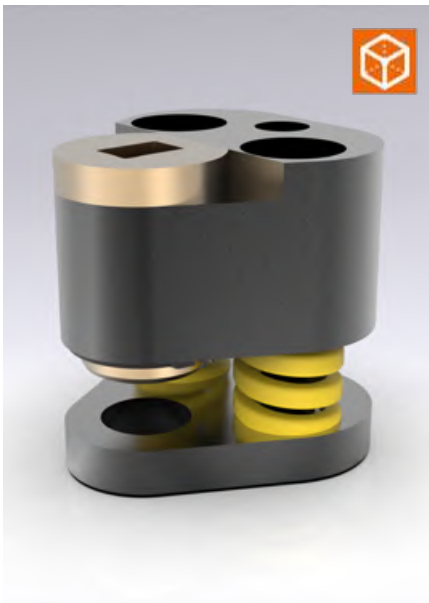

2667.□□5□.

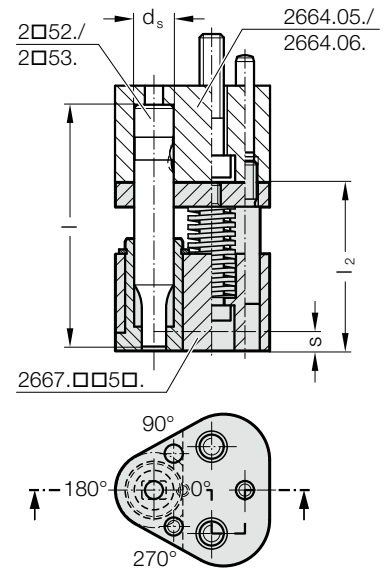
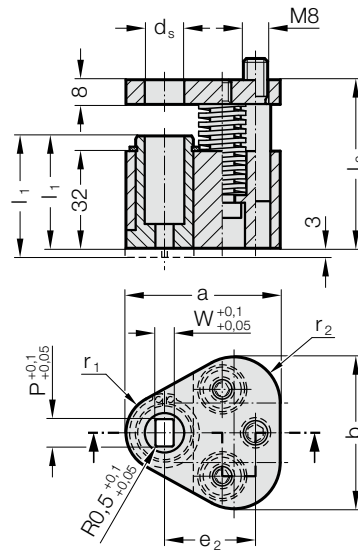

2667.xx5x. POLY STRIP stripper unit, square with radius, for ball-lock punch

d _s / (Order Code character)	W _{min}	G _{max}	a	b	e ₂	r ₁	r ₂	Punch type l ₂	SWL	SWL	SWS	SWL	SWS	I ₁ (Order Code character)	37	40
									(D)	(E)	(G)	(F)	(H)		S _(max)	(A)
10 / (F)	1.6	9.9	44.5	43.7	26.925	9.5	12		80	90	90	100	100		●	●
13 / (G)	4.5	12.9	50.8	50	29.97	12.7	15.2			●	●	●	●		●	●
16 / (H)	6	15.9	54	53.2	31.75	14.3	16.8			●	●	●	●		●	●
20 / (J)	8	19.9	60.3	59.5	33.53	17.5	20			●	●	●	●		●	●
25 / (K)	10	24.9	69.9	69.1	40.64	22.2	24.7			●	●	●	●		●	●
32 / (L)	12.5	31.9	69.9	69.1	40.64	22.2	24.7			●	●	●	●		●	●
38 / (M)	14	37.9	77.4	76	43.9	26	28.5		●	●	●	●			●	●
40 / (N)	14	39.9	77.4	76	43.9	26	28.5				●	●			●	●

d _s / (Order Code character)	Punch type	SWL	SWL	SWL	SWL	SWL	SWL	SWS	SWS	SWS	SWS
	Punch length l	080	080	090	090	100	100	090	090	100	100
	Scraper bush I ₁	37	40	37	40	37	40	37	40	37	40
10 / (F)	Stripping force, max [N]	1022	884	1280	810	786	1098	1280	810	786	1098
13 / (G)		1022	884	1280	810	786	1098	1280	810	786	1098
16 / (H)		2856	1668	3128	1282	1920	2688	3128	1282	1920	2688
20 / (J)		5049	2714	5124	2180	3120	4368	5124	2180	3120	4368
25 / (K)		5049	2714	5124	2180	3120	4368	5124	2180	3120	4368
32 / (L)		5049	2714	5124	2180	3120	4368	5124	2180	3120	4368
38 / (M)		5049	2714	5124	2180	3120	4368				
40 / (N)								5124	2180	3120	4368

Description:

The brush cleaner unit is suitable for use with exterior skin panels.
Use with triangular mounting plate, for ball-lock punch 2664.05./06./10.

Material:

Scraper bush: CuZn25Al5 (no. 2.0598)
Scraper plate: 40CrMnMoS8-6 (no. 1.2312)
Pressure plate: 40CrMnMoS8-6 (no. 1.2312)

Note:

The stripper unit is available in 2 variants: Standard (A) and Long (B).
Long variant of the stripper unit with 3 mm projecting edge suitable for retrofitting a contour.
Choose the position of the cutting form in the scraper bush in accordance with the position of the installed punch in the mounting plate.

Ordering Code (example):

2667.FE5A.0800.0500.A

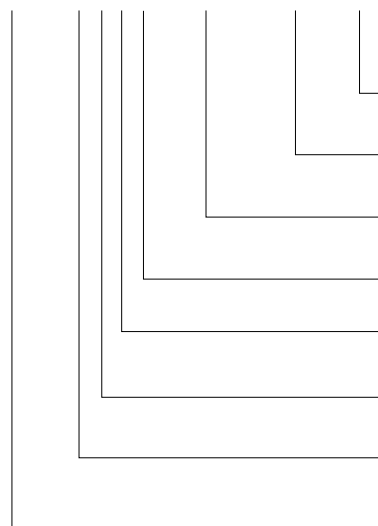

Cutting form position:	Order Code character
0°	= (A)
Shape: rectangle with radiused corners Width W	
W = 5,0 mm	= 0500
Shape: rectangle with radiused corners Length P	
P = 8,0 mm	= 0800
Scraper bush length: I ₁	Order Code character
Standard	= (A)
Cutting form:	Order No
rectangle with radiused corners	= (5)
Punch type/length: I	Order Code character
SWL / I = 90 mm	= (E)
Punch diameter: d ₁	Order Code character
d ₁ = 10 mm	= (F)
Stripper unit	
POLY STRIP	= 2667

SPECIAL PUNCHES AND MATRIXES TO CUSTOMER'S DRAWINGS



FIBRO manufactures special form punches and -matrices on most modern equipment. Projection form grinding, creep feed grinding, EDM and Wire-EDM are used to design details. Many

years of experience enable FIBRO to choose best suitable materials and methods. We manufacture to customer's drawings: Piercing punches, draw punches, form punches, pre-extrusion punches

and ejectors for bolt manufacturing, flow-forming punches, punches with 30°-conical heads or other head shapes

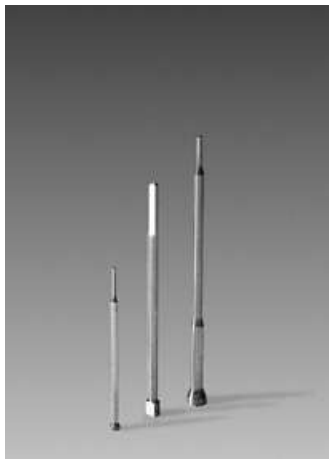

PUNCH WITHOUT HEAD, SQUARE / RECTANGULAR, SHAPE A



230.

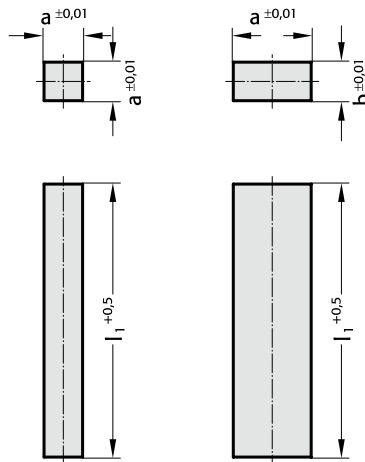

230. Punch without head, square / rectangular, Shape A

a	b	l ₁	l*
1 - 8	1	73.5	71
2 - 10	2	73.5	71
3 - 12	3	73.5	71
4 - 12	4	73.5	71
5 - 15	5	73.5	71
6 - 20	6	73.5	71
7 - 24	7	73.5	71
8 - 24	8	73.5	71
9 - 28	9	73.5	71
10 - 34	10	73.5	71
12 - 34	12	73.5	71

*l = Nominal ordering length

Material:

HSS

Order No 230.3.

Hardness:

Shaft 64 ± 2 HRC

Description of FIBRO materials for tool and die components see at the beginning of Chapter E.

Execution:

Punch shaft precision ground.

l₁: Stock length of square punches: 73,5 mm

Other materials and dimensions on request.

Ordering Code (example):

Punch without head, square / rectangular, Shape A	=	230.
Material MAT	HSS =	3.
Cutting length a	6 mm =	0600.
Cutting width b	6 mm =	0600.
Nominal order length l	71 =	071
Order No	=	230. 3.0600. 0600. 071

PUNCH WITH HEAD, SQUARE / RECTANGULAR, SHAPE B

231.

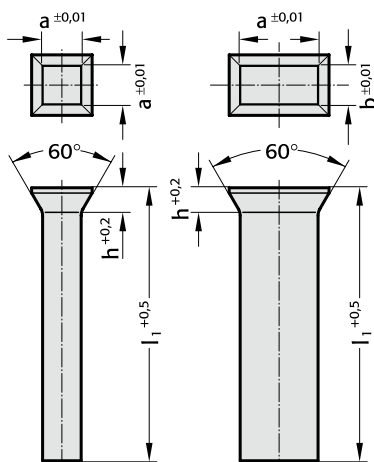

Material:

HSS
Order No 231.3.
Hardness:
Shaft 64 ± 2 HRC
Head 52 ± 3 HRC

Description of FIBRO materials for tool and die components see at the beginning of Chapter E.

Execution:

Punch shaft precision ground.
Heads hot upset forged - ground on special request.

l_1 : Stock length of square punches: 71 mm
Other materials and dimensions on request.

231. Punch with head, square / rectangular, Shape B

a	b	h	l_1
1 - 8	1	1.2	71
2 - 10	2	1.4	71
3 - 12	3	1.8	71
4 - 12	4	1.8	71
5 - 15	5	1.8	71
6 - 20	6	2	71
7 - 24	7	2.8	71
8 - 24	8	2.8	71
9 - 28	9	2.8	71
10 - 34	10	2.8	71
12 - 34	12	2.8	71

Ordering Code (example):

Punch with head, square / rectangular, Shape B	=	231.
Material MAT	HSS	= 3.
Cutting length a	6 mm	= 0600.
Cutting width b	6 mm	= 0600.
Length l_1	71 mm	= 071
Order No		= 231.3.0600. 0600. 071

DOWEL PIN WITH INTERNAL EXTRACTING THREAD, SIMILAR TO DIN EN ISO 8735



236.1.

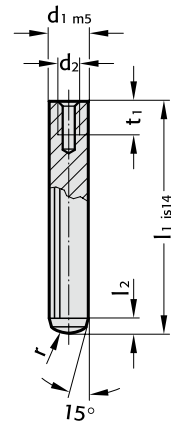

Material:

Steel
Hardness 60 ± 2 HRC

Execution:

hardened and ground to finest finish
FIBRO Dowel Pins are manufactured with the exacting requirements of high class diemaking in mind. Whereas DIN EN ISO 8735 stipulates ISO Class 6 for dowels, we produce our pins to m5.

236.1. Dowel pin with internal extracting thread, similar to DIN EN ISO 8735

d ₁	d ₂	t ₁	l ₂	r	l ₁	16	18	20	24	28	32	36	40	45	50	55	60	70	80	90	100	120
6	M4	6	2.1	6		•	•	•	•	•	•	•	•	•	•	•	•	•	•	•	•	•
8	M5	8	2.6	8				•	•	•		•	•	•	•	•	•	•	•	•	•	•
10	M6	10	3	10					•	•	•	•	•	•	•	•	•	•	•	•	•	•
12	M6	12	3.8	12						•	•	•	•	•	•	•	•	•	•	•	•	•
14	M8	12	4	16							•	•	•	•	•	•	•	•	•	•	•	•
16	M8	16	4.7	16							•	•	•	•	•	•	•	•	•	•	•	•
20	M10	20	6	20								•	•	•	•	•	•	•	•	•	•	•
25	M16	24	6	25									•	•	•	•	•	•	•	•	•	•

Ordering Code (example):

Dowel pin with internal extracting thread, similar to DIN EN ISO 8735	=	236.1.
Diameter d ₁	14 mm =	1400.
Length l ₁	32 mm =	032
Order No	=	236.1. 1400. 032

DOWEL PIN WITH INTERNAL EXTRACTING THREAD, ACCORDING TO DIN EN ISO 8735

2361.1.

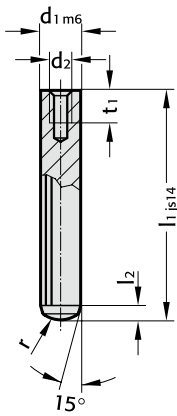

Material:

Steel
Hardness 60 ± 2 HRC

Execution:

hardened and ground to finest finish

2361.1. Dowel pin with internal extracting thread, according to DIN EN ISO 8735

d ₁	d ₂	t ₁	l ₂	r	l ₁	8	10	12	14	16	18	20	22	24	26	28	30	32	36	40	45	50	55	60	70	80	90	100	120
4	M2,5	4.5	1.3	4			•	•	•	•	•	•	•	•	•	•	•	•	•	•	•	•	•	•	•	•	•	•	•
5	M3	5	1.7	5		•	•	•	•	•	•	•	•	•	•	•	•	•	•	•	•	•	•	•	•	•	•	•	•
6	M4	6	2.1	6				•	•	•	•	•	•	•	•	•	•	•	•	•	•	•	•	•	•	•	•	•	•
8	M5	8	2.6	8					•	•	•	•	•	•	•	•	•	•	•	•	•	•	•	•	•	•	•	•	•
10	M6	10	3	10						•	•	•	•	•	•	•	•	•	•	•	•	•	•	•	•	•	•	•	•
12	M6	10	3.8	12								•	•	•	•	•	•	•	•	•	•	•	•	•	•	•	•	•	•
14	M8	12	4	14												•	•	•	•	•	•	•	•	•	•	•	•	•	•
16	M8	12	4.7	16																									
20	M10	16	6	20																									

Ordering Code (example):

Dowel pin with internal extracting thread, according to DIN EN ISO 8735	=	2361.1.
Diameter d ₁	10 mm =	1000.
Length l ₁	16 mm =	016
Order No	=	2361.1. 1000. 016

FIBROZIPP



236.001 FIBROZIPP

Extraction tool for the fast and convenient removal of dowels with internal extracting thread – also for shafts, plugs and other machine components. The tool comes with interchangeable adaptors and screws, to fit all threads from M3 to M16.

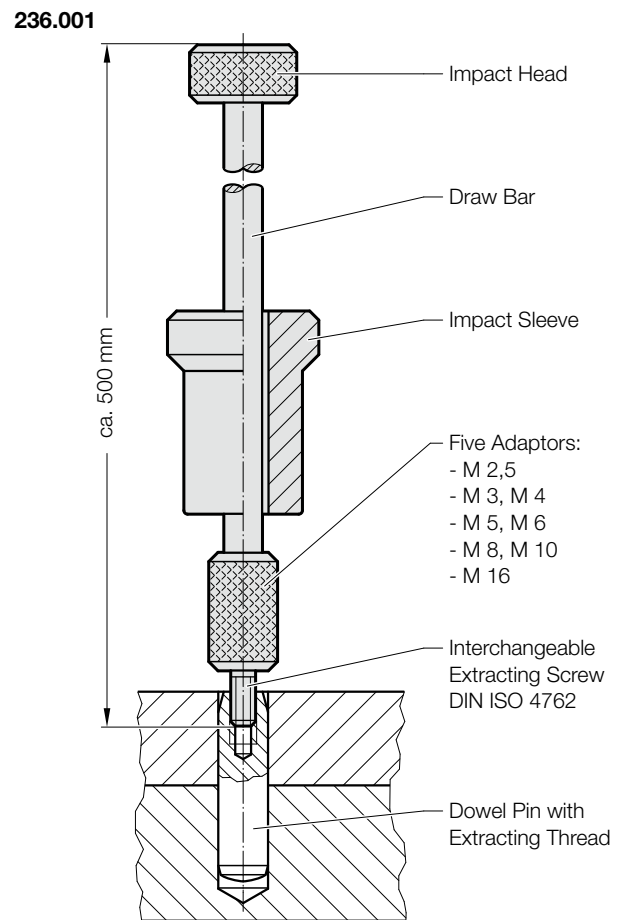

LINER BUSH FOR DOWEL PIN, FOR BONDING

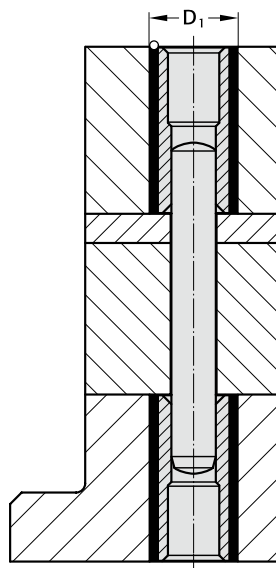

265.1.

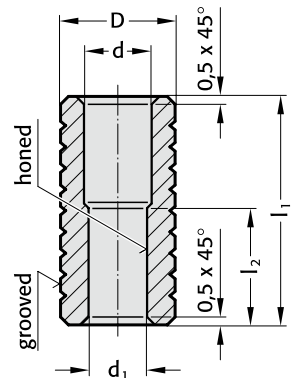

Description:

Dowel liner bushes are used where precisely positioned, unhardened parts are often changed or must be replaced, e.g. in precision tool construction.

Material:

WS
Hardness 54 ± 2 HRC

Epoxy-Bonding:

The jig-ground pin holes of the hardened matrix are joined with the dowel liner bush by means of a dowel pin 235.1. Retainer holes for dowel liner bushes should be approximately 2 mm larger in diameter than the bush O.D. – a coarse finish is desirable. Following exact positioning/aligning, FIBROLIT® ZWO or FIBROFIX® SECHS is used for bonding.

265.1. Liner bush for dowel pin, for bonding

d ₁	d	D	D ₁	l ₁	l ₂
6	7	10	12	25	12
8	9	12	14	30	16
10	11	16	18	36	20

Ordering Code (example):

1 Dowel Liner Bush – only –

Dowel Liner Bush	=	265.
Material WS	=	1.
d ₁ = ø 8,0 mm	=	0800.
Quantity – 1	=	1
Order No	=	265.1.0800.1

Ordering Code (example):

1 Dowel Liner Bush + 1 Dowel pin

Dowel Liner Bush	=	265.
Material WS	=	1.
d ₁ = ø 8,0 mm	=	0800.
Quantity – 1	=	1.
Dowel length = 40 mm	=	040
Order No	=	265.1.0800.1.040

Ordering Code (example):

2 Dowel Liner Bushes + 1 Dowel pin

Dowel Liner Bush	=	265.
Material WS	=	1.
d ₁ = ø 8,0 mm	=	0800.
Quantity – 2	=	5.
Dowel length = 50 mm	=	050
Order No	=	265.1.0800.2.050

LINER BUSH FOR DOWEL PIN, FOR PUSH FIT

2650.1.

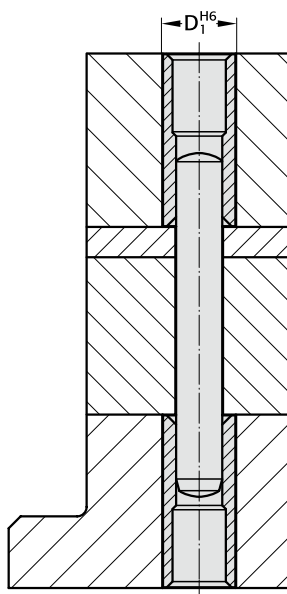
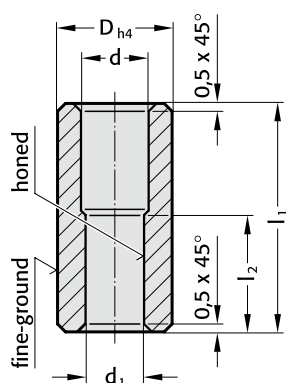

Description:

Dowel liner bushes are used where precisely positioned, unhardened parts are often changed or must be replaced, e.g. in precision tool construction.

Material:

WS
Hardness 54 ± 2 HRC

Slip-Fit Bonding:

The position of the bush is given by push fit hole tolerance H6. The adhesive (order no. 281.648) provides optimum push retention whilst offering the following **advantages**:

- high accuracy and stiffness
- no problems to find position when changing bushings

We do not recommend to press fit bushings.

2650.1. Liner bush for dowel pin, for push fit

d_1	d	d_2	l_1	l_2
6	7	10	25	12
8	9	12	30	16
10	11	16	36	20

Ordering Code (example):

1 Dowel Liner Bush – only –

Dowel Liner Bush	= 2650.
Material WS	= 1.
$d_1 = \varnothing 8,0$ mm	= 0800.
Quantity – 1	= 1
Order No	= 2650.1.0800.1

Ordering Code (example):

1 Dowel Liner Bush + 1 Dowel pin

Dowel Liner Bush	= 2650.
Material WS	= 1.
$d_1 = \varnothing 8,0$ mm	= 0800.
Quantity – 1	= 1.
Dowel length = 40 mm	= 040
Order No	= 2650.1.0800.1.040

Ordering Code (example):

2 Dowel Liner Bushes + 1 Dowel pin

Dowel Liner Bush	= 2650.
Material WS	= 1.
$d_1 = \varnothing 8,0$ mm	= 0800.
Quantity – 2	= 2.
Dowel length = 50 mm	= 050
Order No	= 2650.1.0800.2.050

DOWEL PIN SIMILAR TO DIN EN ISO 8734



235.1.

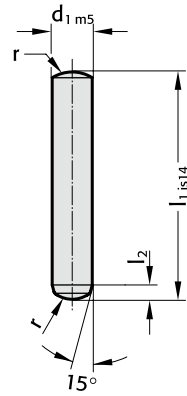

Material:

Steel
Hardness 60 ± 2 HRC

Execution:

hardened and ground to finest finish
FIBRO Dowel Pins are manufactured with the exacting requirements of high class diemaking in mind. Whereas DIN EN ISO 8734 stipulates ISO Class 6 for dowels, we produce our pins to m5.

235.1. Dowel pin similar to DIN EN ISO 8734

d ₁	l ₂	r	l ₁	6	8	10	12	14	16	18	20	24	28	32	36	40	45	50	55	60	70	80	90	100	120	130	140
1	0.48	1			●	●	●																				
1.5	0.62	1.6		●	●	●	●	●	●																		
2	0.78	2		●	●	●	●	●	●	●	●	●	●	●													
2.5	0.95	2.5		●	●	●	●	●	●	●	●	●	●	●	●												
3	1.1	3		●	●	●	●	●	●	●	●	●	●	●	●	●	●										
4	1.4	4		●	●	●	●	●	●	●	●	●	●	●	●	●	●	●	●	●							
5	1.7	5			●	●	●	●	●	●	●	●	●	●	●	●	●	●	●	●	●	●					
6	2.1	6				●	●	●	●	●	●	●	●	●	●	●	●	●	●	●	●	●	●	●	●	●	●
8	2.6	8					●	●	●	●	●	●	●	●	●	●	●	●	●	●	●	●	●	●	●	●	●
10	3	10							●	●	●	●	●	●	●	●	●	●	●	●	●	●	●	●	●	●	●
12	3.8	12									●	●	●	●	●	●	●	●	●	●	●	●	●	●	●	●	●
14	3.8	16													●	●	●	●	●	●	●	●	●	●	●	●	
16	4.7	16														●	●	●	●	●	●	●	●	●	●	●	
20	6	20															●	●	●	●	●	●	●	●	●	●	

Ordering Code (example):

Dowel pin similar to DIN EN ISO 8734	=	235.1.
Diameter d ₁	6 mm =	0600.
Length l ₁	10 mm =	010
Order No	=	235.1.0600. 010

DOWEL PIN ACCORDING TO DIN EN ISO 8734

2351.1.

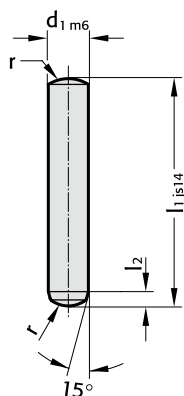

Material:

Steel
Hardness 60 ± 2 HRC

Execution:

hardened and ground to finest finish

2351.1. Dowel pin according to DIN EN ISO 8734

d ₁	l ₂	r	l ₁	4	5	6	8	10	12	14	16	18	20	22	24	26	28	30	32	36	40	45	50	55	60	70	80	90	100	120
1	0.4	1		•	•	•	•	•	•																					
1.5	0.5	1.6		•	•	•	•	•	•	•	•	•	•	•	•	•														
2	0.6	2		•	•	•	•	•	•	•	•	•	•	•	•	•	•	•	•	•	•	•								
2.5	0.7	2.5		•	•	•	•	•	•	•	•	•	•	•	•	•	•	•	•	•	•	•	•	•	•	•	•	•	•	•
3	0.8	3		•	•	•	•	•	•	•	•	•	•	•	•	•	•	•	•	•	•	•	•	•	•	•	•	•	•	•
4	1	4			•	•	•	•	•	•	•	•	•	•	•	•	•	•	•	•	•	•	•	•	•	•	•	•	•	•
5	1.2	5			•	•	•	•	•	•	•	•	•	•	•	•	•	•	•	•	•	•	•	•	•	•	•	•	•	•
6	1.5	6				•	•	•	•	•	•	•	•	•	•	•	•	•	•	•	•	•	•	•	•	•	•	•	•	•
8	1.8	8					•	•	•	•	•	•	•	•	•	•	•	•	•	•	•	•	•	•	•	•	•	•	•	•
10	2	10						•	•	•	•	•	•	•	•	•	•	•	•	•	•	•	•	•	•	•	•	•	•	•
12	2.5	12							•	•	•	•	•	•	•	•	•	•	•	•	•	•	•	•	•	•	•	•	•	•
14	2.5	16								•	•	•	•	•	•	•	•	•	•	•	•	•	•	•	•	•	•	•	•	•
16	3	16									•	•	•	•	•	•	•	•	•	•	•	•	•	•	•	•	•	•	•	•
20	4	20											•	•	•	•	•	•	•	•	•	•	•	•	•	•	•	•	•	•

Ordering Code (example):

Dowel pin according to DIN EN ISO 8734	=	2351.1.
Diameter d ₁	6 mm =	0600.
Length l ₁	8 mm =	008
Order No	=	2351.1. 0600. 008

DRILL BUSH WITH COLLAR, DIN 172 SHAPE A



276.

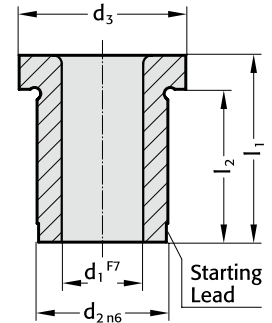

Material:

Case hardened steel
Hardness 740 ± 40 HV 10

Execution:

Diameters d_1 , d_2 and shoulder precision ground.

Other diameters and lengths on request.

276. Drill bush with collar, DIN 172 Shape A

d_1	d_2	d_3	Gradation	l_1	6	8	9	10	12	16	20	25	28	30	36	45	56	67
0,9 - 1	3	6	0.1	l_2	4	8	7											
1,1 - 1,8	4	7	0.1		4		7											
1,9 - 2,6	5	8	0.1		4		7											
2,7 - 3,3	6	9	0.1			5.5			9.5	13.5								
3,4 - 4	7	10	0.1			5.5			9.5	13.5								
4,1 - 5	8	11	0.1			5.5			9.5	13.5								
5,1 - 6	10	13	0.1				7			13	17							
6,1 - 8	12	15	0.1				7			13	17							
8,1 - 10	15	18	0.1					9			17	22						
10,1 - 12	18	22	0.1					8			16	21						
12,1 - 15	22	26	0.1							12			24		32			
15,5 - 18	26	30	0.5							12			24		32			
18,5 - 22	30	34	0.5								15				31	40		
22,5 - 26	35	39	0.5								15				31	40		
26,5 - 30	42	46	0.5									20				40	51	
30,5 - 35	48	52	0.5									20				40	51	
35,5 - 42	55	59	0.5											25			51	62

Ordering Code (example):

Drill bush with collar, DIN 172 Shape A = 276.1.

Diameter of conduit d_1 12.1 mm = 1210.

Length l_1 16 mm = 016

Order No = 276.1. 1210.016

DRILL BUSH WITHOUT COLLAR, DIN 179 SHAPE A

277.

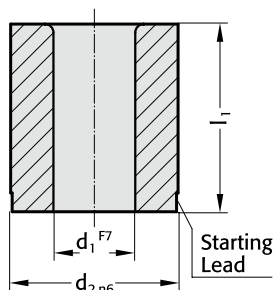

Material:

Case hardened steel
Hardness 740 ± 40 HV 10

Execution:

Diameters d_1 and d_2 precision ground.

Other diameters and lengths on request.

277. Drill bush without collar, DIN 179 Shape A

d_1	d_2	Gradation	l_1	6	8	9	10	12	16	20	25	28	30	36	45	56	67
0,9 - 1	3	0.1		●		●											
1,1 - 1,8	4	0.1		●		●											
1,9 - 2,6	5	0.1		●		●											
2,7 - 3,3	6	0.1			●			●	●								
3,4 - 4	7	0.1			●			●	●								
4,1 - 5	8	0.1			●			●	●								
5,1 - 6	10	0.1					●		●								
6,1 - 8	12	0.1					●		●	●							
8,1 - 10	15	0.1						●	●	●	●						
10,1 - 12	18	0.1						●	●	●	●						
12,1 - 15	22	0.1							●	●	●	●					
15,5 - 18	26	0.5							●		●	●					
18,5 - 22	30	0.5								●	●	●	●				
22,5 - 26	35	0.5								●	●	●	●	●			
26,5 - 30	42	0.5									●	●	●	●	●		
30,5 - 35	48	0.5									●	●	●	●	●	●	
35,5 - 42	55	0.5										●	●	●	●	●	●
42,5 - 48	62	0.5											●	●	●	●	●

Ordering Code (example):

Drill bush without collar, DIN 179 Shape A	=	277.1.
Diameter of conduit d_1	12.1 mm =	1210.
Length l_1	16 mm =	016
Order No	=	277.1. 1210.016

GAUGE PIN DIN 2269



240.1./2.

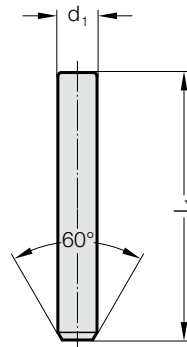

Material:

Alloy tool steel, hardened and tempered.
Age-treated repeatedly.
Hardness 60 ± 2 HRC

Execution:

precision ground
Quality class I: diameter tolerance $\pm 0,001$
Quality class II: diameter tolerance $\pm 0,002$

Single pins:

Quality class I 240.1.
Quality class II 240.2.

240.1./2. Gauge pin DIN 2269

d_1	l_1
0,1 - 0,99	40
1 - 20	70

Ordering Code (example):

Gauge pin DIN 2269	=	240.
quality class KL	1	= 1.
Diameter d_1	1,29 mm	= 0129.
Length l_1	70 mm	= 070
Order No		= 240. 1. 0129. 070

EXAMPLE APPLICATIONS FOR CHECK PINS

Direct gauging of bore diameters

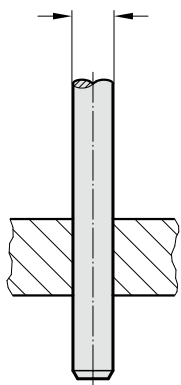

Measurement of centre-distance between two bores

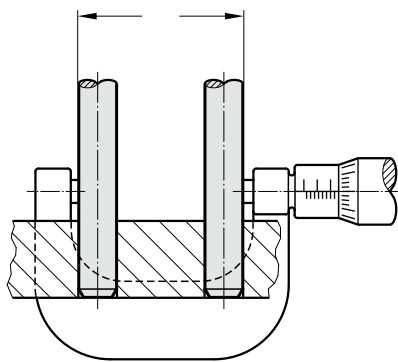

Concentricity check on a bush

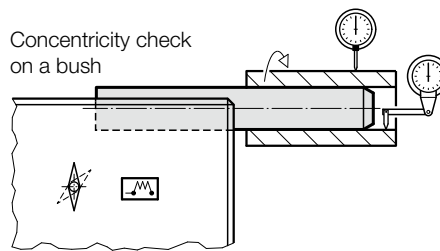

Measurements on prismatic faces

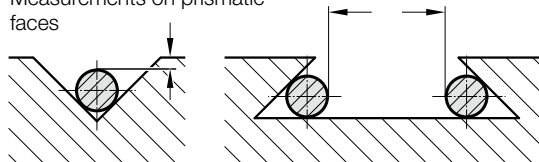

Calibration of a comparator

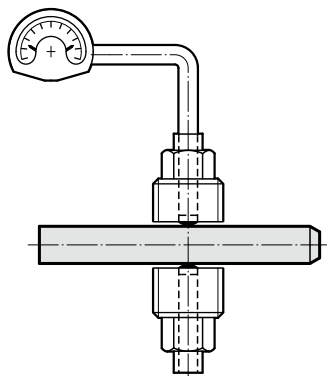

Inspection for squareness of a bore

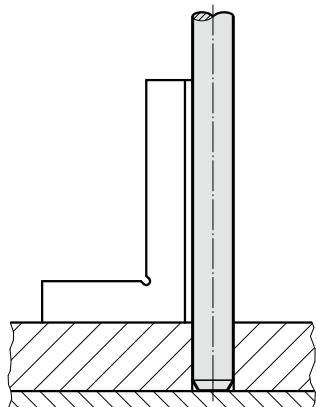

Check on parallelism

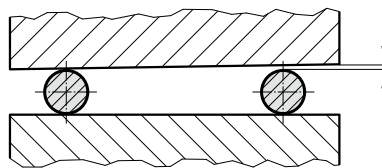

Measuring of gear teeth, threads etc.

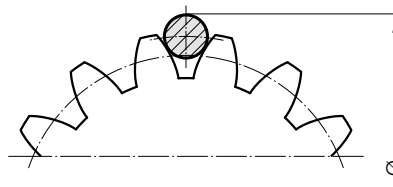

GAUGE PIN HOLDERS WOODEN BOXES



240.45. Gauge Pin Holders

Gauge Pin Holders are double-ended, to carry two pins e.g. for go – no go measurements etc.

(without pins)	for diameters	Order No
	of 1–2	240.45.1
	of 2–4	240.45.2
	of 4–6	240.45.3
	of 6–8	240.45.4
	of 8–10	240.45.5



240.51/52 Range of check pins, small, in storage box

91 check pins, DIN 2269, from \varnothing 1-10 mm increasing by 0.1 mm, complete set in storage box with drilled inserts and measurement markings. From \varnothing 3 mm the check pins are marked with the measurements.

	Order No
quality class I	240.51.
quality class II	240.52.

240.41/42 Range of check pins, large, in storage box

273 check pins, DIN 2269, from \varnothing 1-10 mm increasing by 0.1 mm. Each check pin size is each expanded once again with a -0.01 mm undersize and a +0.01 mm oversize, complete set in storage box with drilled inserts and measurement markings.

From \varnothing 3 mm the check pins are marked with the measurements.

	Order No
quality class I	240.41.
quality class II	240.42.

Custom ranges:

Available in quality classes I and II according to your specifications. From \varnothing 3 mm the check pins are marked with the measurements.

240.91/92 Wooden boxes:, no content

Wooden storage boxes for protected and tidy storage of check pins. Without check pins. Without drilled insert and measurement markings.

(no content)	Order No
For large set of approx. 270 items with approx. external dimensions 250x90x390	240.91
For small set of approx. 90 items with 240.92 approx. external dimensions 155x90x285	

GAUGE PIN WITH HANDLE, DIN 2269

240.11./22.

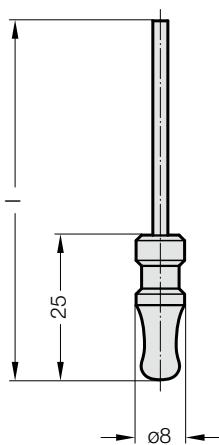

240.11./22. Gauge pin with handle, DIN 2269

The Gauge Pins are firmly fixed to the handle. Each Pin is marked with its true diameter.

Single Gauge Pins: \varnothing 0.5 – 3.0 mm, increasing in diameter by 0.01

	Order No.		
quality class I	240.11.	+	+
quality class II	240.22.	+	+

d_1	l
0,5 - 0,99	58
1 - 3	88

Material:

Alloy tool steel, hardened and repeatedly age-treated.
 Hardness 60 ± 2 HRC
 Extremely finely ground
 Quality class I ± 0.001
 Quality class II ± 0.002
 Conforming to DIN 2269

Ordering Code (example):

Gauge pin with handle, DIN 2269 = 240.11.
 quality class I
 $d_1 = 1,5$ mm = 0150
 Order No = 240.11.0150

PUNCHING AND EMBOSING UNIT WITH MATRIX FOR PUNCHED HOLES AND SELF TAPPING SCREWS



Material:

HSS

Execution:

The punching and embossing unit with matrix consists of:

1 x embossing die

1 x punch die

1 x matrix

Sheet metal thickness:

max. 0,6 mm = 2282.01.035/039

max. 0,8 mm = 2282.01.042

max. 0,9 mm = 2282.01.048

max. 1,0 mm = 2282.01.055/063

2282.01. Punching and embossing unit with matrix for punched holes and self tapping screws

Order No	Nominal-Ø = Thread size	d ₁	d ₂	d _{3h6}	d _{4k6}	d _{5h6}	d ₆	d ₇	d _{8h6}	d _{9k6}	l ₁	l ₂	l ₃	l ₄	l ₅
2282.01.035	B 3,5	2.75	3.2	7.5	3.75	2.7	2.7	3.1	7.5	3.75	31.3	28	74.5	71.5	60
2282.01.039	B 3,9	3.05	3.4	7.5	3.75	3	3	3.6	7.5	3.75	31.3	28	74.5	71.5	60
2282.01.042	B 4,2	3.15	3.5	8.5	4.25	3.1	3.1	3.7	8	4	31.3	28	74.5	71.5	60
2282.01.048	B 4,8	3.85	4.2	9	4.5	3.8	3.8	4.5	8	4	31.3	28	74.5	71.5	60
2282.01.055	B 5,5	4.35	4.8	9	4.5	4.3	4.3	5	8	4	31.3	28	74.5	71.5	60
2282.01.063	B 6,3	4.85	5.3	10.5	5.25	4.8	4.8	5.5	10	5	31.3	28	74.5	71.5	60

2282.01.xxx

2282.01.xxx.1 Embossing die

2282.01.xxx.2 Punch die

2282.01.xxx.3 Bottom die

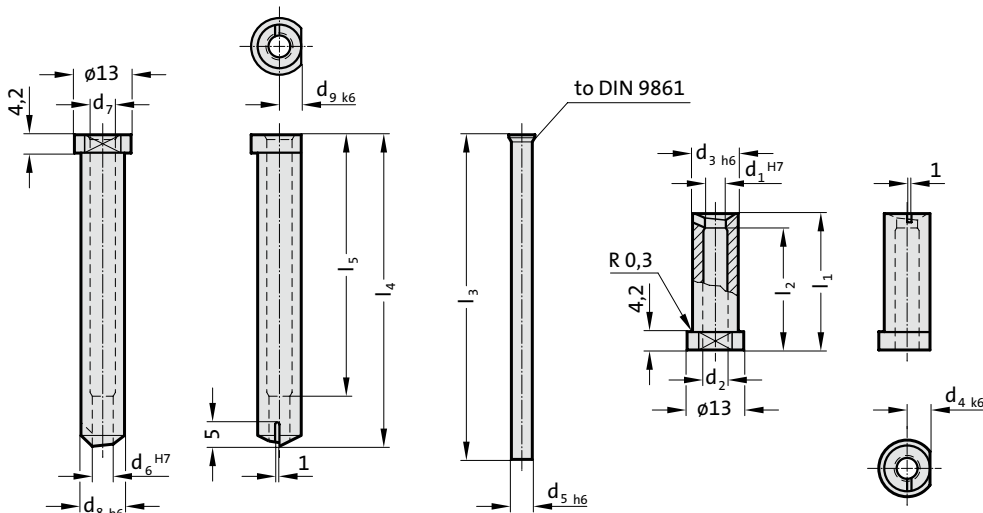

Example of application:

