























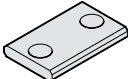

CONTENTS

		D21-23					
	Notes on guide elements						202.17. D32 Guide pillar with ball cage retainer
		D24-25					202.19. .30.94 D33 Guide pillar with cage retainer bore
	Guide elements - Pairing classification						202.22. D34 Guide pillar with internal thread on both sides, ~DIN 9825/~ISO 9182-2
	Guide elements - Selection matrix	D26					202.23. D35 Guide pillar with internal thread on bottom, ~DIN 9825/~ISO 9182-2
	Deflection of Pillars and Bending equation	D27					202.24. D36 Guide pillar with internal thread on top, ~DIN 9825/~ISO 9182-2
	Guide elements and accessories - Example applications	D28-29					202.21. D37 Guide pillar endwise bolt-on type, ~DIN 9825/~ISO 9182-2
	206.51. Ball cage, small dimension	D30					202.55. D38-39 Guide pillar endwise bolt-on type with ball cage, ~DIN 9825/~ISO 9182-2
	206.54. Guide bush for ball bearing, small dimension	D30					202.29. D40 Guide pillar ECO-LINE, ~DIN 9825/~ISO 9182-2
	202.19. Guide pillar DIN 9825/ISO 9182-2	D31					

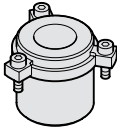
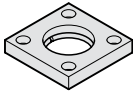
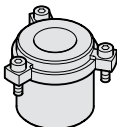
CONTENTS

	202.31. Guide pillar ECO-LINE endwise bolt-on type, ~DIN 9825/~ISO 9182-2	D42-43		2022.13. Guide pillar with 5° pilot taper, to VW-Standard	D52
	2021.50. Guide pillar, conical, DIN 9825/ISO 9182-4/AFNOR	D44-45		2022.15. Guide pillar with pilot taper, VDI 3356	D53
	2021.58. Demountable guide pillar, conical, with ball cage retainer, DIN 9825/ISO 9182-4/AFNOR	D46-47		2022.17. Guide pillar with groove, to VW	D54
	2021.53. Retaining disc with countersunk head cap screw, DIN 9825/ISO 9182-4	D48		2022.40.1. Locating plate for guide pillar, to VW	D55
	202.53. Retaining disc with socket cap screw, ~AFNOR	D48		2022.25. Guide pillar with retaining ring groove, ~AFNOR	D56
	2021.39. Retaining bush for guide pillar conical 2021.50., DIN 9825/ISO 9182-4	D49		2073.46. Clamping flange with retaining ring, ~AFNOR	D57
	210.39. Retaining bush for guide pillar conical 2021.50., ~AFNOR	D50		2022.16. Guide pillar with snap ring groove, to Mercedes-Benz Standard	D58-59
	2022.19. Guide pillar for large tools, DIN 9833/ISO 9182-3	D51		2022.12. Guide pillar with pilot taper and groove, to Mercedes-Benz Standard	D60

CONTENTS



2061.48. **D61**
Snap ring

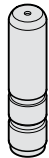

2022.16.45. **D62**
Guide pillar with groove, to CNOMO

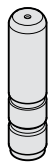

2022.16.48. **D63**
Guide pillar with groove

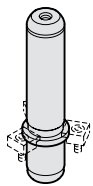

2022.29. **D64**
Guide pillar with collar, to WDX

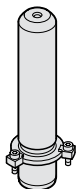

2021.46. **D66-67**
Guide pillar with collar, screw clamp retention, DIN 9825/~ISO 9182-5

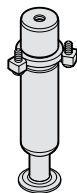

2021.44. **D68-69**
Guide pillar with collar and ball cage retainer

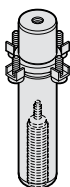

2021.46. .30.94 **D70-71**
Guide pillar with collar, with cage unit bore

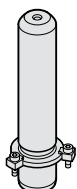

2021.28. **D72-73**
Guide pillar with collar

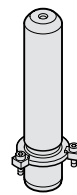

2021.29. **D74-75**
Guide pillar with collar ECO-LINE



2021.43. **D76**
Retaining disc with screw

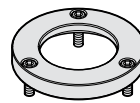

2021.45. **D76**
Retainer ring for guide pillars with collar

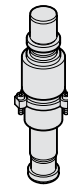

2025.94. **D77**
Ball guide unit to Mercedes-Benz Standard



202.61. **D78**
Guide pillar with collar



2062.44.012. **D79**
Guide bush for ball bearing, for highest stroking speed











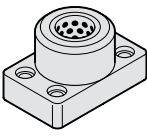

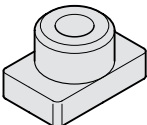
2061.44. **D79, D107**
Guide bush for ball bearing, ISO 9448-3

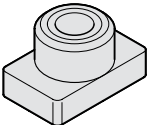
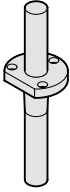
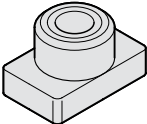

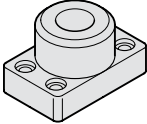
206.41. **D80**
Ball cage, plastic, for highest stroking speed

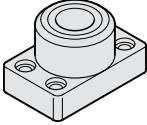
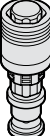
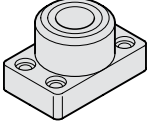
CONTENTS

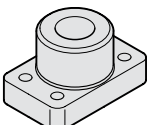
	2020.63. Demountable guide pillar with centre fixing	D81		2031.70. Guide bearing with solid lubricant	D92
	2020.62. Demountable guide pillar with centre fixing	D82-83		2031.01. Retention bearing	D93
	202.60. Demountable guide pillar with centre fixing and ring nut	D84		2031.31. Guide bearing, sintered guide	D94
	2020.64. Demountable guide pillar with conical centre fixing	D85		2031.41. Guide bearing for ball bearing guide	D95
	2021.64. Retaining bush for guide pillar conical 2020.64.	D86		2031.02. Retention bearing with screw holes	D96
	2073.48. Slotted nut DIN 1804	D87		2031.34. Guide bearing with screw holes, sintered guide	D97
	2024.94. Guide unit with collar MILLION GUIDE	D88-89		2031.42. Guide bearing with screw holes, for ball bearing guide	D98
	2024.96. Guide unit with center fixing MILLION GUIDE	D90-91		2031.04. Retention bearing, low build height	D99

CONTENTS

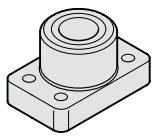

2031.38. **D100**

Guide bearing, low build height, sintered guide

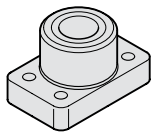

2031.44. **D101**

Guide bearing low build height, for ball bearing guide

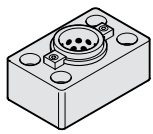

2032.70. **D102**

Guide bearing with headed guide bush with solid lubricant

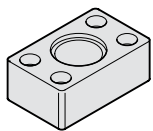

2032.02. **D103**

Retention bearing for guide pillars for large tools

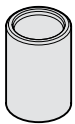

2051.32. **D104**

Guide bush, sintered ferrite carbonitrided with long-term lubrication, ISO 9448-2

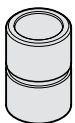

2051.92. **D105**

Guide bush ECO-LINE, bronzeplated, ISO 9448-2

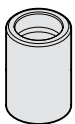

2051.72. **D106**

Guide bush ECO-LINE, Bronze with solid lubrication rings, ISO 9448-2

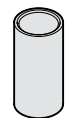

206.49. **D108**

Guide bush for ball bearing, AFNOR



2061.47. **D109**

Guide bush for ball bearing, with stroke limitation



206.71. **D110**

Ball cage with circlip groove, Brass



2060.61. **D111**

Ball cage with circlip groove, Aluminium



2060.41. **D112**

Ball cage with circlip groove, plastic



206.73. **D114**

Ball cage with assembly aid, Brass



2060.63. **D115**

Ball cage with assembly aid, Aluminium

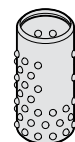

206.75. **D116**

Ball cage with circlip and fastening ring groove, Brass

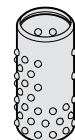

2060.65. **D117**

Ball cage with circlip and fastening ring groove, Aluminium

CONTENTS

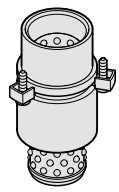

2081.67. **D118**

Headed guide bush with ball cage retainer

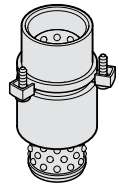

2081.68. **D119**

Headed guide bush with ball cage retainer

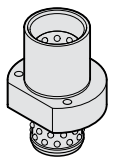

2091.67. **D120**

Flanged guide bush with ball cage retainer

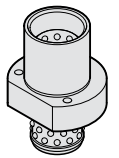

2091.68. **D121**

Flanged guide bush with ball cage retainer

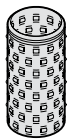

2061.82. **D122**

Roller cage with circlip groove, Brass



206.72. **D123**

Circlip DIN 471

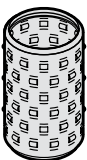

2061.84. **D124**

Roller cage with assembly aid, Brass

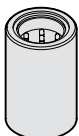

2061.69. .1 **D125**

Recirculating ball bush ~ISO9448-3

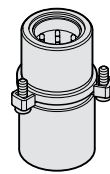

2081.69. .1 **D126**

Recirculating ball bush with collar ~ISO9448-7

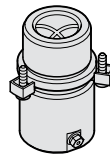

2081.81. **D127**

Headed guide bush, bronze coated, ISO 9448-6

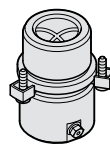

2081.84. **D128**

Headed guide bush, bronze coated, ISO 9448-6

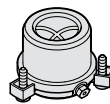

2081.85. **D129**

Headed guide bush, bronze coated, ISO 9448-6

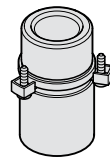

2081.31. **D130**

Headed guide bush, sintered ferrite carbonitrided with long-term lubrication, ISO 9448-6

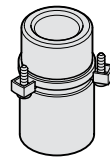

2081.32. **D131**

Headed guide bush, sintered ferrite carbonitrided with long-term lubrication, ISO 9448-6

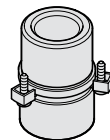

2081.33. **D132**

Headed guide bush, sintered ferrite carbonitrided with long-term lubrication, ISO 9448-6

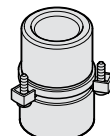

2081.34. **D133**

Headed guide bush, sintered ferrite carbonitrided with long-term lubrication, ISO 9448-6

CONTENTS

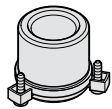

2081.35. **D134**

Headed guide bush, sintered ferrite carbonitrided with long-term lubrication, ISO 9448-6

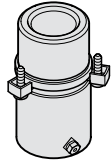

2081.91. **D135**

Headed guide bush ECO-LINE, bronzeplated, ISO 9448-6

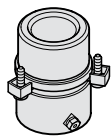

2081.94. **D136**

Headed guide bush ECO-LINE, bronzeplated, ISO 9448-6

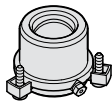

2081.95. **D137**

Headed guide bush ECO-LINE, bronzeplated, ISO 9448-6

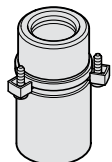

2081.71. **D138**

Headed guide bush ECO-LINE, Bronze with solid lubricant rings, ISO 9448-6

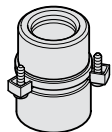

2081.74. **D139**

Headed guide bush ECO-LINE, Bronze with solid lubricant rings, ISO 9448-6

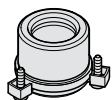

2081.75. **D140**

Headed guide bush ECO-LINE, Bronze with solid lubricant rings, ISO 9448-6

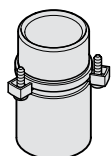

2081.44. **D141**

Headed guide bush for ball bearing, ISO 9448-7

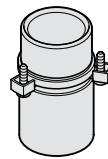

2081.45. **D142**

Headed guide bush for ball bearing, ISO 9448-7

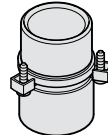

2081.46. **D143**

Headed guide bush for ball bearing, ISO 9448-7

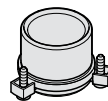

2081.47. **D144**

Headed guide bush for ball bearing, ISO 9448-7

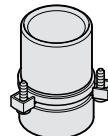

2081.49. **D145**

Headed guide bush for ball bearing, ISO 9448-7

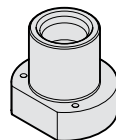

2091.31. **D146**

Flanged guide bush, sintered ferrite carbonitrided with long-term lubrication, ISO 9448-4

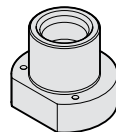

2091.32. **D147**

Flanged guide bush, sintered ferrite carbonitrided with long-term lubrication, ISO 9448-4

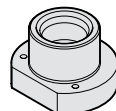

2091.34. **D148**

Flanged guide bush, sintered ferrite carbonitrided with long-term lubrication, ISO 9448-4

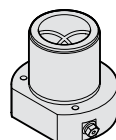

2091.91. **D149**

Flanged guide bush ECO-LINE, bronzeplated, ISO 9448-4

CONTENTS

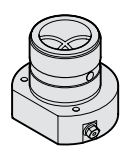

2091.92. **D150**

Flanged guide bush ECO-LINE,
bronzeplated, ISO 9448-4

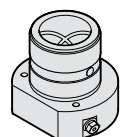

2091.94. **D151**

Flanged guide bush ECO-LINE,
bronzeplated, ISO 9448-4

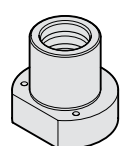

2091.71. **D152**

Flanged guide bush ECO-LINE,
Bronze with solid lubricant rings,
ISO 9448-4

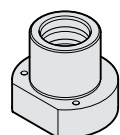

2091.72. **D153**

Flanged guide bush ECO-LINE,
Bronze with solid lubricant rings,
ISO 9448-4

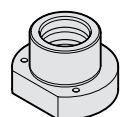

2091.74. **D154**

Flanged guide bush ECO-LINE,
Bronze with solid lubricant rings,
ISO 9448-4

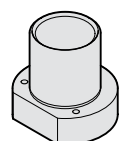

2091.44. **D155**

Flanged guide bush for ball bearing,
ISO 9448-5

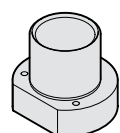

2091.45. **D156**

Flanged guide bush for ball bearing,
ISO 9448-5

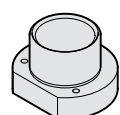

2091.46. **D157**

Flanged guide bush for ball bearing,
ISO 9448-5

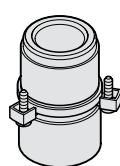

210.31. **D158**

Headed guide bush, sintered ferrite
carbonitrided with long-term
lubrication, ~AFNOR

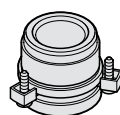

210.34. **D159**

Headed guide bush, sintered ferrite
carbonitrided with long-term
lubrication, ~AFNOR

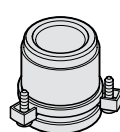

210.35. **D160**

Headed guide bush, sintered ferrite
carbonitrided with long-term
lubrication, ~AFNOR

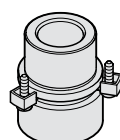

210.44. **D162-163**

Headed guide bush for ball bearing,
~AFNOR

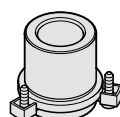

210.46. **D164-165**

Headed guide bush for ball bearing,
~AFNOR

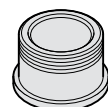

210.45. **D166**

Guide bush with collar, for ball
bearing, ~AFNOR

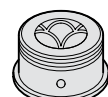

210.85. **D167**



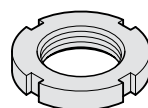







Guide bush with collar, bronze
coated, ~AFNOR



207.48. **D168**

Slotted nut

CONTENTS

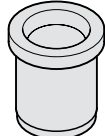
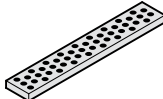
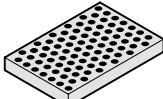
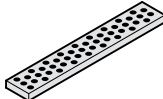
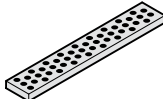
		D170					
	Oilless guide elements						
	2053.70.	D171					
	Thrust washer, Bronze with solid lubricant						
	2052.70.	D172-173					
	Guide bush, Bronze with solid lubricant						
	2085.70.	D174					
	Guide bush with collar, Bronze with solid lubricant						
	2085.71.	D175					
	Guide bush with collar, Bronze with solid lubricant						
	2086.70.	D176					
	Guide bush with collar, Bronze with solid lubricant						
	2085.72.	D177					
	Guide bush with collar, Bronze with solid lubricant						
	2082.70.	D178					
	Guide bush with collar, Bronze with solid lubricant, DIN 9834/ISO 9448						
					2082.71.	D179	
					Guide bush with collar, Bronze with solid lubricant, NAAMS		
					2086.71.	D180	
					Guide bush with collar, Bronze with solid lubricant, NAAMS		
					2102.70.	D181	
					Guide bush with collar, Bronze with solid lubricant, CNOMO		
					2102.71.	D182	
					Guide bush with collar, Bronze, CNOMO		
					2961.71.	D183	
					Flat guide bar, Bronze with solid lubricant		
					2961.76.	D184	
					Flat guide bar, Bronze with solid lubricant		
					2961.77.	D185	
					Flat guide bar, Bronze with solid lubricant		
					2961.73.	D186	
					Flat guide bar with two sliding surfaces, Bronze with solid lubricant		

CONTENTS

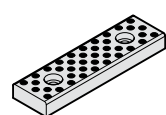

2961.70. **D187**

Flat guide bar, Bronze with solid lubricant

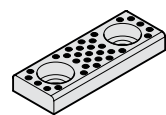

2961.75. **D188**

Flat guide bar, Bronze with solid lubricant

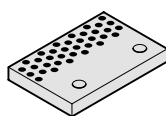

2961.74. **D189**

Retaining plate, Bronze with solid lubricant, VDI 3357

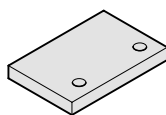

2961.79. **D190**

Retaining plate, Steel, VDI 3357

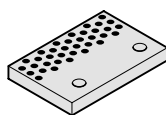

2961.81. **D191**

Retaining plate, Steel with solid lubricant, VDI 3357

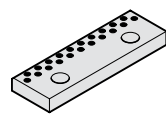

2961.78. **D192**

Retaining plate, Bronze with solid lubricant

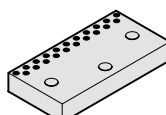

2961.82. **D193**

Retaining plate, Steel with solid lubricant, NAAMS

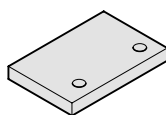

2961.79.45. **D194**

Retaining plate, Steel, CNOMO

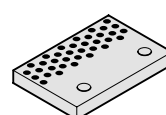

2961.81.45. **D195**

Retaining plate, Bronze with solid lubricant, CNOMO

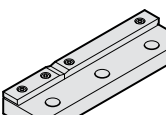

2961.30.55. **D196-197**

Retaining plate with sliding pad, Steel / Steel with sinterlayer, according to VW

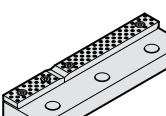

2961.74.55. **D198-199**

Retaining plate with sliding pad, Steel / Bronze with solid lubricant, according to VW

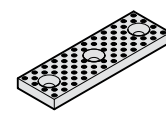

2960.72. **D200**

Sliding pad, small dimension, Bronze with solid lubricant

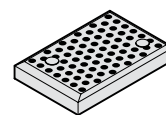

2960.71. **D202-203**

Sliding pad, Bronze with solid lubricant, VDI 3357 / ISO 9183-1

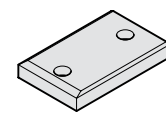

2960.87. **D204-205**

Sliding pad, Steel, VDI 3357

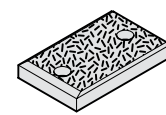

2960.30. **D206-207**

Sliding pad, Steel with sinterlayer, VDI 3357

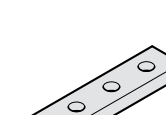

2960.31. **D208**

Sliding pad, Steel with sinterlayer, VDI 3357

CONTENTS

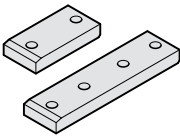
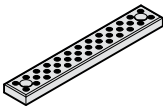
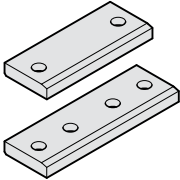
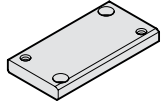
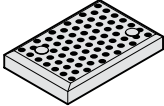
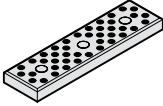
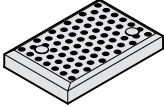
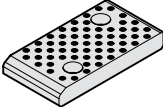
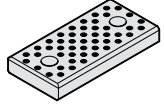
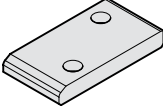
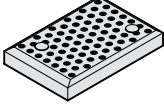
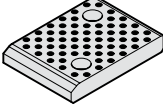
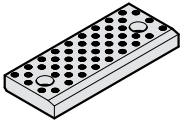
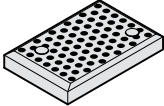
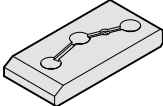
	2960.32. Sliding pad, Steel with sinterlayer, VDI 3357	D209		2962.78. Sliding pad, Bronze with solid lubricant	D220-221
	2960.33. Sliding pad, Steel with sinterlayer, VDI 3357	D210		2962.84.45. Sliding pad, Steel, CNOMO	D222
	2960.70. Sliding pad, Bronze with solid lubricant	D212-213		2962.85. Sliding pad, Steel with solid lubricant	D223
	2960.85. Sliding pad, Bronze with solid lubricant	D214		2960.79. Sliding pad, Bronze with solid lubricant, NAAMS	D224
	2960.86. Sliding pad, Bronze with solid lubricant	D215		2960.80. Sliding pad, Steel, NAAMS	D225
	2960.76. Sliding pad, Bronze with solid lubricant	D216		2960.74. Sliding pad, Bronze with solid lubricant, AFNOR/ISO 9183-2	D226-227
	2960.77. Sliding pad, Bronze with solid lubricant, VDI 3357	D217			
	2962.78.45. Sliding pad, Bronze with solid lubricant, CNOMO	D218		2960.44.45. Sliding pad, Steel with oil groove, CNOMO	D230-231

CONTENTS

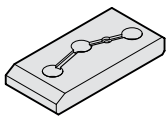

2960.54.45. **D232**
Sliding pad, Bronze with oil groove,
CNOMO

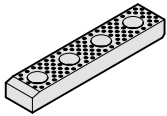

2960.81. **D234-235**
Sliding pad, Bronze with solid
lubricant, VDI 3357

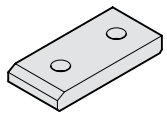

2960.88. **D236-237**
Sliding pad, Steel, VDI 3357

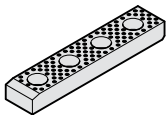

2960.93. **D238**
Sliding pad, Bronze with solid
lubricant, VDI 3357

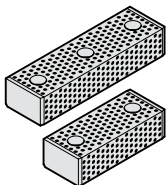

2962.75. **D239**
Guide bar with two sliding surfaces,
Bronze with solid lubricant, VDI 3357

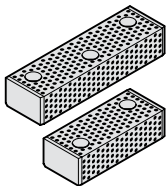

2962.75.45. **D240**
Guide bar with two sliding surfaces,
Bronze with solid lubricant, CNOMO

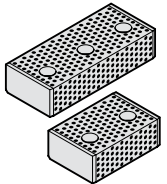

2962.76. **D241**
Guide bar with three sliding surfaces,
Bronze with solid lubricant

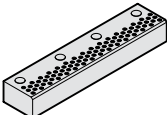

2962.77. **D242**
Guide bar with two sliding surfaces,
Bronze with solid lubricant

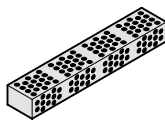

2962.74. **D243**
Guide bar with four sliding surfaces,
Bronze with solid lubricant

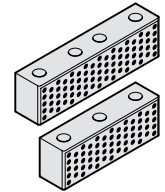

2962.79. **D244**
Guide bar with one sliding surfaces,
Bronze with solid lubricant

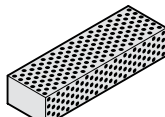

2962.80. **D245**
Guide bar with three sliding surfaces,
Bronze with solid lubricant

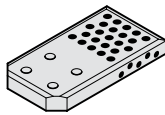

2960.73. **D246**
Guide bracket, Steel with solid
lubricant, VDI 3387

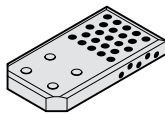

2960.89. **D247**
Guide bracket, Bronze with solid
lubricant, VDI 3387

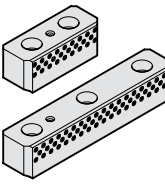

2966.72. **D248**
Slide centre guide, Bronze with solid
lubricant

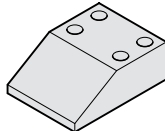

2960.90. **D249**
Overrun Cam, Steel hardened,
VDI 3357

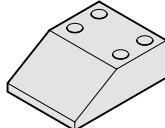

2960.91. **D250**
Overrun Cam, Steel hardened and
gas nitrided, VDI 3357

CONTENTS

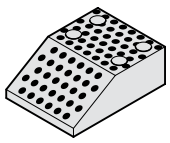

2960.92. **D251**
 Overrun Cam, Bronze with solid lubricant, VDI 3357

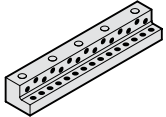

2962.70. **D252**
 Angled guide gib, Bronze with solid lubricant

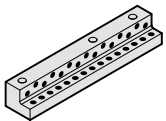

2962.70.45. **D253**
 Angled guide gib, Bronze with solid lubricant, CNOMO

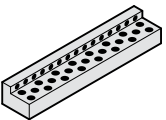

2962.71. **D254**
 Angled guide gib, Bronze with solid lubricant

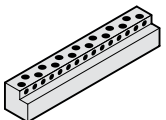

2962.72. **D255**
 Angled guide gib, Bronze with solid lubricant

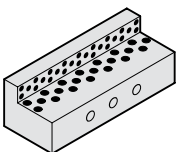

2962.73. **D256**
 Angled guide gib, Bronze with solid lubricant, VDI 3357

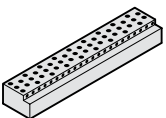

2962.81. **D257**
 Angled guide gib, Bronze with solid lubricant

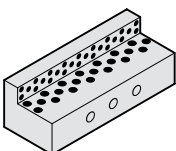

2962.82. **D258**
 Angled guide gib, Bronze with solid lubricant

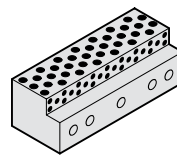

2962.83. **D259**
 Angled guide gib, Bronze with solid lubricant

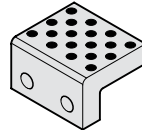

2962.86. **D260**
 Angled guide gib, Bronze with solid lubricant

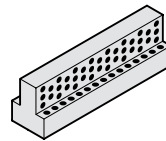

2964.77. **D261**
 T-Guide bar, Bronze with solid lubricant

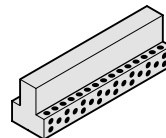

2964.78. **D261**
 T-Guide bar, Bronze with solid lubricant

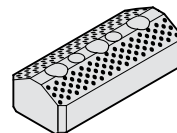

2963.82. **D262**
 Sliding block, Bronze with solid lubricant, NAAMS

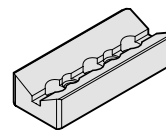

2963.83. **D262**
 Prismatic guide, Steel, NAAMS

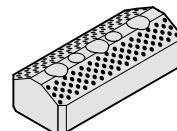

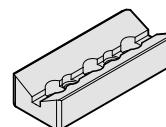

2963.84. **D263**
 Sliding block, Bronze with solid lubricant, VDI 3357

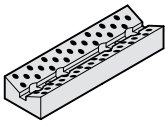
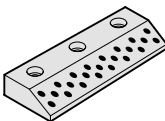
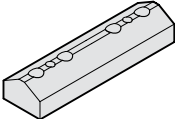
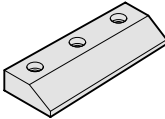
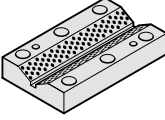
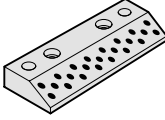
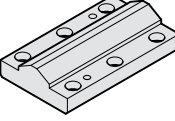
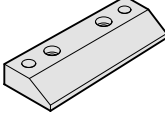
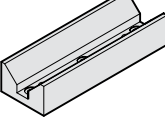
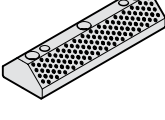
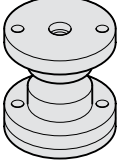
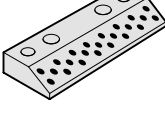
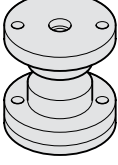
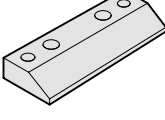

2963.85. **D263**
 Prismatic guide, Steel, VDI 3357

CONTENTS

	2963.70. Prismatic guide, Bronze with solid lubricant	D264		2965.80.45. Single-sided prismatic guide, Bronze with solid lubricant, CNOMO	D270
	2963.71. Sliding block, Steel	D264		2965.82.45. Single-sided prismatic sliding block, Steel, CNOMO	D271
	2963.72. Prismatic guide, Bronze with solid lubricant	D265		2965.80. Single-sided prismatic guide, Bronze with solid lubricant	D272
	2963.73. Sliding block, Steel	D265		2965.82. Single-sided prismatic sliding block, Steel	D273
	2963.81. Prismatic guide, Steel	D266	D274-277 Oilless guide elements - Mounting examples		
	2963.80. Sliding block, Bronze with solid lubricant	D267		2441.11.0. Centering unit with adjusting washer	D278
	2965.81. Single-sided prismatic guide, Bronze with solid lubricant	D268		2441.11. Centering unit	D279
	2965.83. Single-sided prismatic sliding block, Steel	D269		2441.11.3. Adjusting washer	D280

CONTENTS

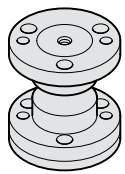

2441.13.45. **D281**

Centering unit, CNOMO

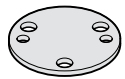

2441.13.3.45. **D282**

Adjusting washer, CNOMO

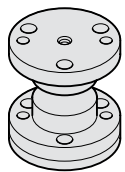

2441.13. **D283**

Centering unit, CNOMO

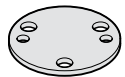

2441.13.3. **D284**

Adjusting washer, CNOMO

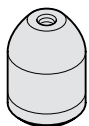

2445.10. **D285**

Centering pin



2445.11. **D286**

Centering pin to Mercedes-Benz Standard

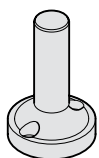

2446.10.55. **D287**

Pressure bolt with base, according to VW

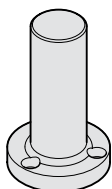

2446.11.55. **D288**

Air pin, according to VW standard

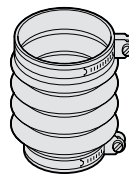

206.91. **D289**

Concertina shroud with spacer bush

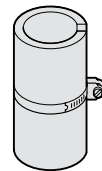

206.94. **D290**

Spacer tube

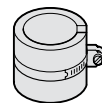

206.93. **D290**

Spacer bush

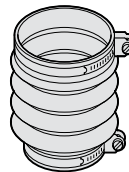

206.92. **D291**

Concertina shroud with spacer tube



241.18. **D292**

Helical spring for ball cage retention

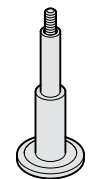

202.91. **D293**

Cage retainer

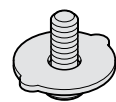

202.92.1. **D294**

Cage retainer

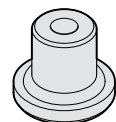

202.93. **D295**

Cage retainer

CONTENTS

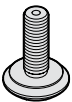
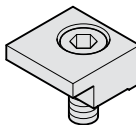
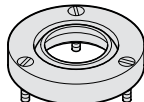
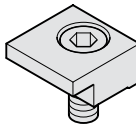
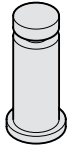
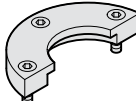
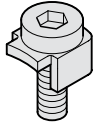
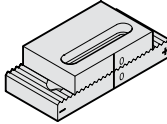
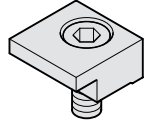
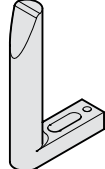
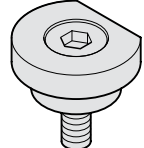
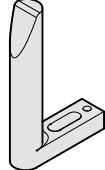
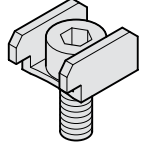
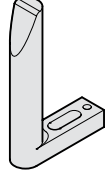
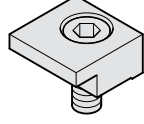
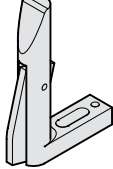
	202.94. Cage retainer	D296		2072.46 Screw clamp with screw	D302
	206.95./2061.95. Pillar wiper	D297		2072.48.45. Screw clamp with screw, CNOMO	D303
	244.00.2. Lifter pin for press tool strips	D298		2073.45. Securing flange with screws, CNOMO	D303
	207.45 Screw clamp with screw	D300		2444.12 / 2444.13 Spacer plate toothed, with adjusting plate	D304
	2072.45. Screw clamp with screw	D300		2443.10. Guide	D305
	2071.45 Screw clamp with screw	D301		2443.10.20. Guide to Mercedes-Benz Standard - unhardened	D306
	2072.47 Screw clamp with screw, NAAMS	D302		2443.10.20. .1 Guide to Mercedes-Benz Standard - hardened	D307
	2072.46.30. Screw clamp with screw, GM Standard	D302		2443.12. Guide with part position control and spring	D308

CONTENTS

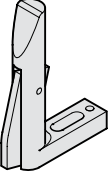
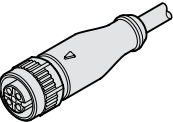
	2443.13.	D309		
	Guide with part position control, VDI			D316
			Ball guides - load diagram	
	2018.00.60.08.030	D310		D317-319
	Inductive proximity switch			
			Ball guides - calculation table	
	2018.00.60.23.01.	D311		D320-327
	Cable - straight			
			Guide elements - Installation guidelines, dimension tables	
	2018.00.60.23.02.	D311		
	Cable, 90° connector			
	2443.14.55.	D313		
	Position monitor for boards			
	2443.14.00.60.18.044	D314		
	Inductive proximity switch			
	2443.14.00.60.23.01.	D315		
	Cable - straight			
	2443.14.00.60.23.02.	D315		
	Cable, 90° connector			

GUIDE PILLAR DIN 9825/ISO 9182-2

202.19.

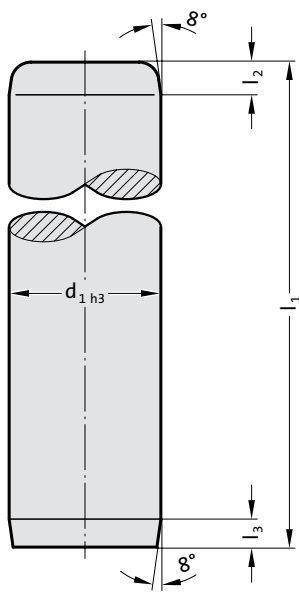

Mounting example

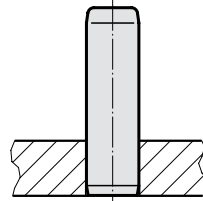

Material:

Steel, (Core strength: $\geq 900 \text{ N/mm}^2$) surface hardened
 Surface hardness: $60 + 3 \text{ HRC}$, Hardness penetration $\geq 1,8 \text{ mm}$ (up to $\phi 12$, throughhardened)

Execution:

fine-ground and superfinished
 Method of manufacturing entails that centre holes are not concentric with O.D.

Note:

$\phi 3$ to $\phi 8$ are not supplied classified.
 $\phi 10$ to $\phi 12$ only available in tolerance range yellow = .10

- Bearing clearance / Preloading see pairing classification at the beginning of chapter D.
 - Matching guide combinations, see selection matrix at the beginning of chapter D.
 - Assembly guide lines / Dimensional requirements and tolerances at the end of chapter D.
- Tolerance range:
 yellow = .10; green = .20; red = .30

202.19. Guide pillar DIN 9825/ISO 9182-2

d_1	3	4 5	6	8	10	11 12	15 16	19 20	24 25	30 32	38 40	48 50	60 63	80
l_2	2	2	2	3	3	3	4	4	6	6	6	8	8	8
l_3	2	2	2	3	3	3	3	3	3	3	3	3	3	3
l_1														
30	●													
40	●	●	●											
50	●	●	●	●										
60	●	●	●	●										
80	●	●	●	●		●								
90					●	●	●							
100		●	●	●	●	●	●	●	●					
112					●	●	●	●	●					
125			●	●	●	●	●	●	●	●				
140			●	●	●	●	●	●	●	●				
160			●	●		●	●	●	●	●	●			
180							●	●	●	●	●	●		
200							●	●	●	●	●	●	●	
224							●	●	●	●	●	●	●	
250							●	●	●	●	●	●	●	●
280							●	●	●	●	●	●	●	●
315							●	●	●	●	●	●	●	●
355							●	●	●	●	●	●	●	●
400								●	●	●	●	●	●	●
450								●	●	●	●	●	●	●
500								●	●	●	●	●	●	●
550									●	●	●	●	●	●
600										●	●	●	●	●
700											●	●	●	●
800												●	●	●

Ordering Code (example):

Guide pillar DIN 9825/ISO 9182-2	=	202.19.
Diameter of conduit d_1	25 mm	= 025.
Length l_1	224 mm	= 224.
Classification TOL	yellow	= 10
Order No		= 202.19. 025. 224. 10

GUIDE PILLAR WITH BALL CAGE RETAINER



Mounting example

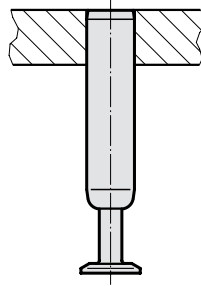

202.17.

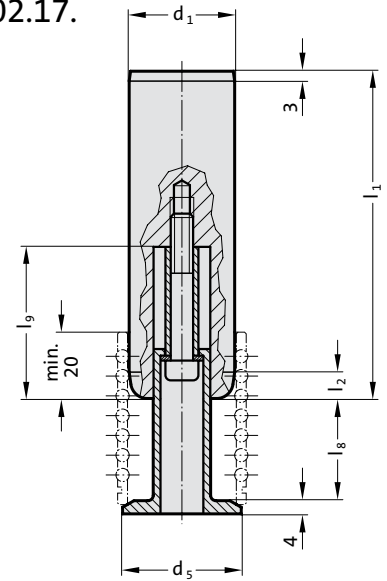

Material:

Steel, (Core strength: $\geq 900 \text{ N/mm}^2$) surface hardened
 Surface hardness: 60 + 3 HRC, Hardness penetration $\geq 1,8 \text{ mm}$

Execution:

fine-ground and superfinished

Note:

- ☞ Preloading see pairing classification at the beginning of chapter D
- ☞ Matching guide combinations, see selection matrix at the beginning of chapter D.

☞ Assembly guide lines / Dimensional requirements and tolerances at the end of chapter D.

Dimensions of ball cage retainer see 202.91.

Tolerance range:

yellow = .10

green = .20

red = .30

202.17. Guide pillar with ball cage retainer

d ₁	38	40	48	50	60	63
d ₅	42	44	52	54	64	67
l ₂	6	6	8	8	8	8
KG (l ₈ / l ₉)						
1 (31/46)	●	●	●	●	●	●
2 (41/56)	●	●	●	●	●	●
3 (51/66)	●	●	●	●	●	●
4 (61/76)	●	●	●	●	●	●
5 (73/89)	●	●	●	●	●	●
l ₁						
160	●	●				
180	●	●	●			
200	●	●	●	●		
224	●	●	●	●		
250	●	●	●	●	●	
280	●	●	●	●	●	●
315	●	●	●	●	●	●
355	●	●	●	●	●	●
400	●	●	●	●	●	●
450	●	●	●	●	●	●
500	●	●	●	●	●	●
550	●	●	●	●	●	●
600	●	●	●	●	●	●
700	●	●	●	●	●	●
800	●	●	●	●	●	●

Ordering Code (example):

Guide pillar with ball cage retainer		= 202.17.
Diameter of conduit d ₁	48 mm	= 048.
Length l ₁	550 mm	= 550.
Cage unit size KG	1	= 1.
Classification TOL	yellow	= 10
Order No		= 202.17. 048. 550. 1. 10

GUIDE PILLAR WITH CAGE RETAINER BORE

202.19. .30.94

Mounting example

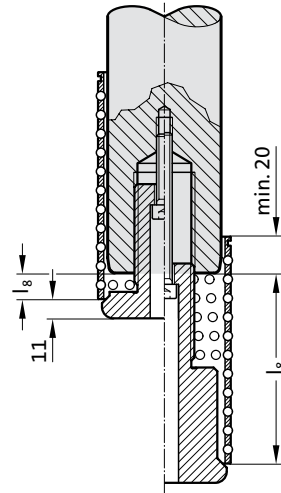
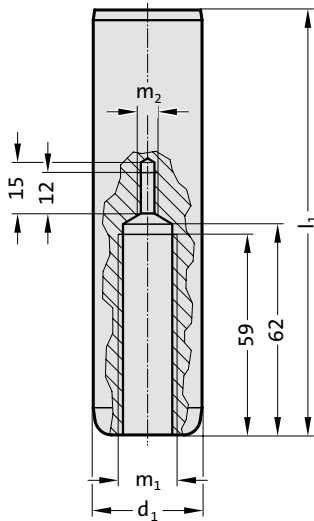

Material:

Steel, (Core strength: $\geq 900 \text{ N/mm}^2$) surface hardened
Surface hardness: $60 + 3 \text{ HRC}$, Hardness penetration $\geq 1,8 \text{ mm}$

Execution:

fine-ground and superfinished

Note:

- Preloading see pairing classification at the beginning of chapter D
- Matching guide combinations, see selection matrix at the beginning of chapter D.

Dimensions of ball cage retainer see 202.94.

Tolerance range: red = .30

Delivery without cage retainer, ball cage and head cap screw.

202.19. .30.94 Guide pillar with cage retainer bore

d_1	30 32	38 40	48 50	60 63	80
m_1	M16x1,5	M16x1,5	M20x1,5	M30x1,5	M30x1,5
m_2	M5	M5	M6	M8	M8
l_1					
125	●				
140	●				
160	●	●			
180	●	●	●		
200	●	●	●		
224	●	●	●		
250	●	●	●	●	
280	●	●	●	●	●
315	●	●	●	●	●
355	●	●	●	●	●
400	●	●	●	●	●
450	●	●	●	●	●
500	●	●	●	●	●
550		●	●	●	●
600		●	●	●	●
700		●	●	●	●
800		●	●	●	●

Ordering Code (example):

Guide pillar with cage retainer bore	=	202.19.
Diameter of conduit d_1	48 mm =	048.
Length l_1	224 mm =	224.
Classification red TOL	30 =	30.
Cage unit bore KHB	=	94
Order No	=	202.19. 048. 224. 30.94

GUIDE PILLAR WITH INTERNAL THREAD ON BOTH SIDES, ~DIN 9825/~ISO 9182-2



Mounting example

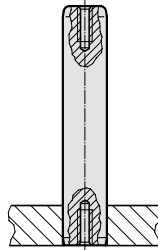

202.22.

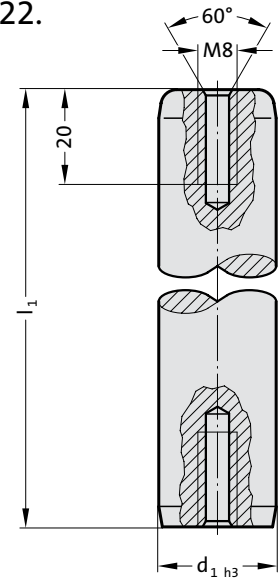

Material:

Steel, (Core strength: $\geq 900 \text{ N/mm}^2$) surface hardened
 Surface hardness: $60 + 3 \text{ HRC}$, Hardness penetration $\geq 1,8 \text{ mm}$

Execution:

fine-ground and superfinished
 Method of manufacturing entails that centre holes are not concentric with O.D.

Note:

☞ Bearing clearance / Preloading see pairing classification at the beginning of chapter D.

☞ Matching guide combinations, see selection matrix at the beginning of chapter D.

☞ Assembly guide lines / Dimensional requirements and tolerances at the end of chapter D.

Tolerance range:

yellow = .10

green = .20

red = .30

202.22. Guide pillar with internal thread on both sides, ~DIN 9825/~ISO 9182-2

d_1	15 16	19 20	24 25	30 32	38 40	48 50	60 63	80
l_2	4	4	6	6	6	8	8	8
l_1								
90	●							
100	●	●	●					
112	●	●	●					
125	●	●	●	●				
140	●	●	●	●				
160	●	●	●	●	●			
180	●	●	●	●	●	●		
200	●	●	●	●	●	●	●	
224	●	●	●	●	●	●	●	
250	●	●	●	●	●	●	●	
280	●	●	●	●	●	●	●	●
315	●	●	●	●	●	●	●	●
355	●	●	●	●	●	●	●	●
400		●	●	●	●	●	●	●
450			●	●	●	●	●	●
500			●	●	●	●	●	●
550					●	●	●	●
600					●	●	●	●
700					●	●	●	●
800					●	●	●	●

Ordering Code (example):

Guide pillar with internal thread on both sides, ~DIN 9825/~ISO 9182-2		= 202.22.
Diameter of conduit d_1	32 mm	= 032.
Length l_1	200 mm	= 200.
Classification TOL	yellow	= 10
Order No		= 202.22. 032. 200. 10

GUIDE PILLAR WITH INTERNAL THREAD ON BOTTOM, ~DIN 9825/~ISO 9182-2

202.23.

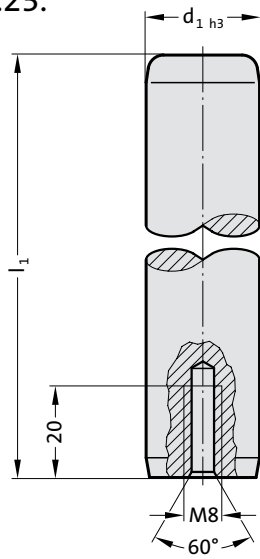

Mounting example

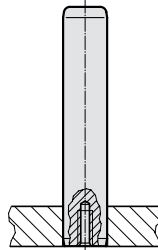

Material:

Steel, (Core strength: $\geq 900 \text{ N/mm}^2$) surface hardened
 Surface hardness: $60 + 3 \text{ HRC}$, Hardness penetration $\geq 1,8 \text{ mm}$

Execution:

fine-ground and superfinished
 Method of manufacturing entails that centre holes are not concentric with O.D.

Note:

Bearing clearance / Preloading see pairing classification at the beginning of chapter D.

Matching guide combinations, see selection matrix at the beginning of chapter D.

Assembly guide lines / Dimensional requirements and tolerances at the end of chapter D.

Tolerance range:

yellow = .10

green = .20

red = .30

202.23. Guide pillar with internal thread on bottom, ~DIN 9825/~ISO 9182-2

d_1	15 16	19 20	24 25	30 32	38 40	48 50	60 63	80
l_2	4	4	6	6	6	8	8	8
l_1								
90	●							
100	●							
112	●	●	●					
125	●	●	●	●				
140	●	●	●	●				
160	●	●	●	●	●			
180	●	●	●	●	●	●		
200	●	●	●	●	●	●		
224	●	●	●	●	●	●		
250	●	●	●	●	●	●	●	
280	●	●	●	●	●	●	●	●
315	●	●	●	●	●	●	●	●
355	●	●	●	●	●	●	●	●
400		●	●	●	●	●	●	●
450			●	●	●	●	●	●
500			●	●	●	●	●	●
550				●	●	●	●	●
600				●	●	●	●	●
700				●	●	●	●	●
800					●	●	●	●

Ordering Code (example):

Guide pillar with internal thread on bottom, ~DIN 9825/~ISO 9182-2	= 202.23.
Diameter of conduit d_1	32 mm = 032.
Length l_1	200 mm = 200.
Classification TOL	yellow = 10
Order No	= 202.23. 032. 200. 10

GUIDE PILLAR WITH INTERNAL THREAD ON TOP, ~DIN 9825/~ISO 9182-2



Mounting example

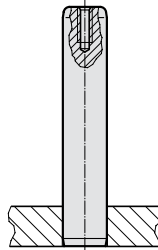

202.24.

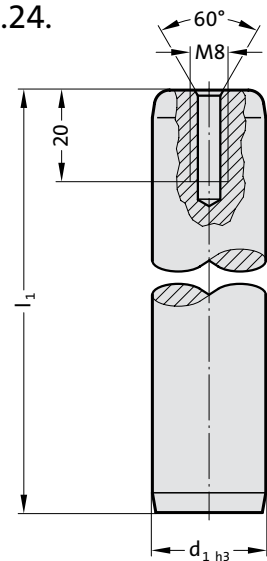

Material:

Steel, (Core strength: $\geq 900 \text{ N/mm}^2$) surface hardened
 Surface hardness: 60 + 3 HRC, Hardness penetration $\geq 1,8 \text{ mm}$

Execution:

fine-ground and superfinished
 Method of manufacturing entails that centre holes are not concentric with O.D.

Note:

☞ Bearing clearance / Preloading see pairing classification at the beginning of chapter D.

☞ Matching guide combinations, see selection matrix at the beginning of chapter D.

☞ Assembly guide lines / Dimensional requirements and tolerances at the end of chapter D.

Tolerance range:

yellow = .10

green = .20

red = .30

202.24. Guide pillar with internal thread on top, ~DIN 9825/~ISO 9182-2

d_1	15 16	19 20	24 25	30 32	38 40	48 50	60 63	80
l_2	4	4	6	6	6	8	8	8
l_1								
90	●							
100	●	●	●					
112	●	●	●					
125	●	●	●	●				
140	●	●	●	●				
160	●	●	●	●	●			
180	●	●	●	●	●	●		
200	●	●	●	●	●	●		
224	●	●	●	●	●	●		
250	●	●	●	●	●	●	●	
280	●	●	●	●	●	●	●	●
315	●	●	●	●	●	●	●	●
355	●	●	●	●	●	●	●	●
400		●	●	●	●	●	●	●
450			●	●	●	●	●	●
500			●	●	●	●	●	●
550				●	●	●	●	●
600				●	●	●	●	●
700				●	●	●	●	●
800				●	●	●	●	●

Ordering Code (example):

Guide pillar with internal thread on top, ~DIN 9825/~ISO 9182-2	=	202.24.
Diameter of conduit d_1	32 mm =	032.
Length l_1	200 mm =	200.
Classification TOL	yellow =	10
Order No	=	202.24. 032. 200. 10

GUIDE PILLAR ENDWISE BOLT-ON TYPE, ~DIN 9825/~ISO 9182-2

202.21.

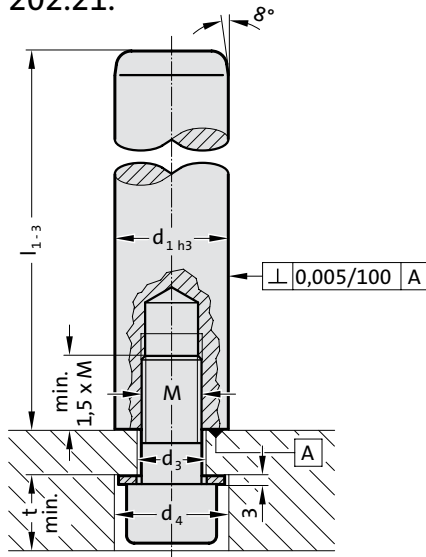

Hole pattern for column (pillar) fastening

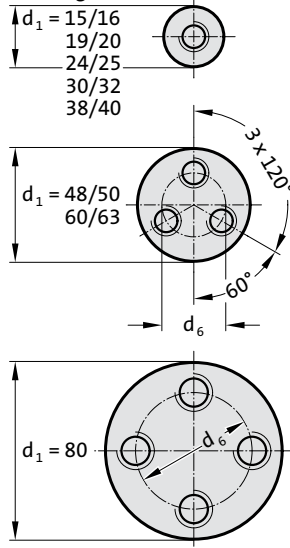

Material:

Steel, (Core strength: $\geq 900 \text{ N/mm}^2$) surface hardened
Surface hardness: $60 + 3 \text{ HRC}$, Hardness penetration $\geq 1,8 \text{ mm}$

Execution:

fine precision ground
End face square within 0.005 mm in 100 mm

Note:

Bearing clearance / Preloading see pairing classification at the beginning of chapter D.

Matching guide combinations, see selection matrix at the beginning of chapter D.

Tolerance range:

yellow = .10
green = .20
red = .30

202.21. Guide pillar endwise bolt-on type, ~DIN 9825/~ISO 9182-2

d_1	15 16	19 20	24 25	30 32	38 40	48 50	60 63	80
d_3	9	11	14	18	18	14	18	18
d_4	17	20	22	28	28	22	28	28
d_6	-	-	-	-	-	28	34	54
t	12	14	16	20.5	20.5	16	20.5	20.5
M	8	10	12	16	16	12	16	16
Screw	M8x35	M10x40	M12x40	M16x40	M16x40	M12x50	M16x60	M16x60
Tightening torque [Nm]	21	37	85	150	150	85	200	200
l_1								
90	●							
100	●	●	●					
112	●	●	●					
125	●	●	●	●				
140	●	●	●	●				
160	●	●	●	●	●			
180	●	●	●	●	●	●		
200	●	●	●	●	●	●		
224	●	●	●	●	●	●		
250	●	●	●	●	●	●	●	
280	●	●	●	●	●	●	●	●
315	●	●	●	●	●	●	●	●
355	●	●	●	●	●	●	●	●
400		●	●	●	●	●	●	●
450			●	●	●	●	●	●
500			●	●	●	●	●	●
550				●	●	●	●	●
600				●	●	●	●	●
700				●	●	●	●	●
800				●	●	●	●	●

Ordering Code (example):

Guide pillar endwise bolt-on type, ~DIN 9825/~ISO 9182-2	=	202.21.
Diameter of conduit d_1	32 mm	= 032.
Length l_1	200 mm	= 200.
Classification TOL	yellow	= 10
Order No		= 202.21. 032. 200. 10

GUIDE PILLAR ENDWISE BOLT-ON TYPE WITH BALL CAGE, ~DIN 9825/~ISO 9182-2



202.55.

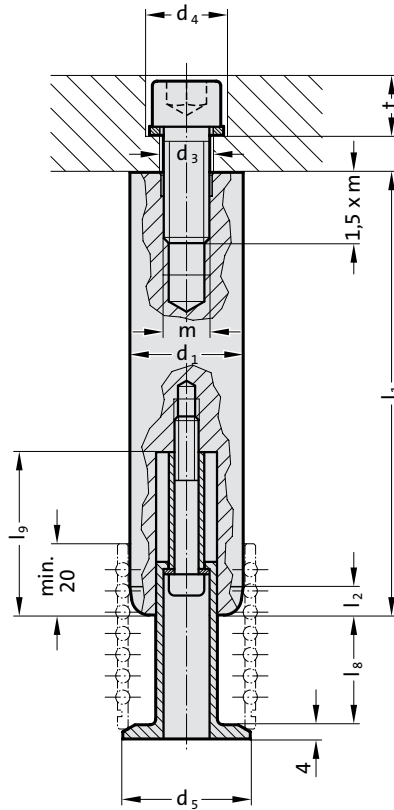

Material:

Steel, (Core strength: $\geq 900 \text{ N/mm}^2$) surface hardened
Surface hardness: 60 + 3 HRC, Hardness penetration $\geq 1,8 \text{ mm}$

Execution:

fine precision ground
End face square within 0.005 mm in 100 mm

Note:

Preloading see pairing classification at the beginning of chapter D

Matching guide combinations, see selection matrix at the beginning of chapter D.

Dimensions of ball cage retainer see 202.91.

Tolerance range:

yellow = .10

green = .20

red = .30

Hole pattern for column (pillar) fastening

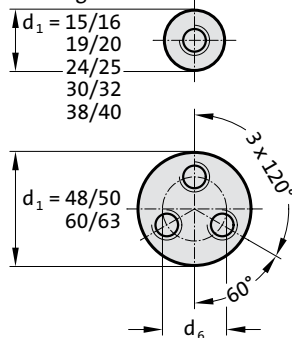

GUIDE PILLAR ENDWISE BOLT-ON TYPE WITH BALL CAGE, ~DIN 9825/~ISO 9182-2

202.55. Guide pillar endwise bolt-on type with ball cage, ~DIN 9825/~ISO 9182-2

d ₁	38	40	48	50	60	63
d ₃	18	18	14	14	18	18
d ₄	28	28	22	22	28	28
d ₅	42	44	52	54	64	67
d ₆	0	0	28	28	34	34
t	20.5	20.5	16	16	20.5	20.5
m	16	16	12	12	16	16
Screw	M16x40	M16x40	M12x50	M12x50	M16x60	M16x60
Tightening torque [Nm]	150	150	85	85	200	200
KG (l ₈ / l ₉)						
1 (31/46)	●	●	●	●	●	●
2 (41/56)	●	●	●	●	●	●
3 (51/66)	●	●	●	●	●	●
4 (61/76)	●	●	●	●	●	●
5 (73/89)	●	●	●	●	●	●
l ₁						
160	●	●				
180	●		●	●		
200	●	●	●	●		
224	●	●	●	●		
250	●	●	●	●	●	●
280	●	●	●	●	●	●
315	●	●	●	●	●	●
355	●	●	●	●	●	●
400	●	●	●	●	●	●
450	●	●	●	●	●	●
500	●	●	●	●	●	●
550	●	●	●	●	●	●
600	●	●	●	●	●	●
700	●	●	●	●	●	●
800	●	●	●	●	●	●

Ordering Code (example):

Guide pillar endwise bolt-on type with ball cage,
~DIN 9825/~ISO 9182-2

= 202.55.

Diameter of conduit d₁ 48 mm = 048.

Length l₁ 550 mm = 550.

Cage unit size KG 1 = 1.

Classification TOL yellow = 10

Order No = 202.55. 048. 550. 1. 10

GUIDE PILLAR ECO-LINE, ~DIN 9825/~ISO 9182-2



Mounting example

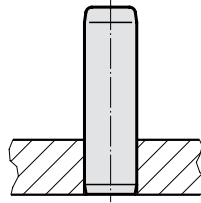

202.29.

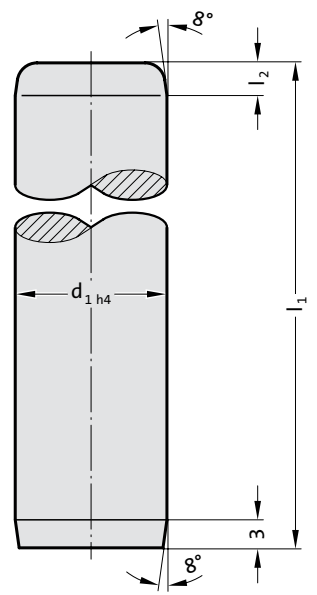

Material:

Steel, surface hardened
 Surface hardness: 60 + 3 HRC, Hardness penetration ≥ 1,8 mm

Execution:

ground
 Method of manufacturing entails that centre holes are not concentric with O.D.

Note:

Guide pillars only recommended for use with sliding guides!
 ☞ Matching guide combinations, see selection matrix at the beginning of chapter D.
 ☞ Assembly guide lines / Dimensional requirements and tolerances at the end of chapter D.

202.29. Guide pillar ECO-LINE, ~DIN 9825/~ISO 9182-2

d ₁	15 16	19 20	24 25	30 32	38 40	48 50	60 63	80
l ₂	4	4	6	6	6	8	8	8
l ₁								
90	●							
100	●							
112	●	●	●					
125	●	●	●	●				
140	●	●	●	●				
160	●	●	●	●	●			
180	●	●	●	●	●	●		
200	●	●	●	●	●	●		
224	●	●	●	●	●	●		
250	●	●	●	●	●	●	●	
280	●	●	●	●	●	●	●	●
315	●	●	●	●	●	●	●	●
355	●	●	●	●	●	●	●	●
400		●	●	●	●	●	●	●
450			●	●	●	●	●	●
500			●	●	●	●	●	●
550				●	●	●	●	●
600					●	●	●	●
700					●	●	●	●
800					●	●	●	●

Ordering Code (example):

Guide pillar ECO-LINE, ~DIN 9825/~ISO 9182-2	=	202.29.
Diameter of conduit d ₁	32 mm =	032.
Length l ₁	125 mm =	125
Order No	=	202.29. 032. 125

GUIDE PILLAR ECO-LINE ENDWISE BOLT-ON TYPE, ~DIN 9825/~ISO 9182-2



202.31.

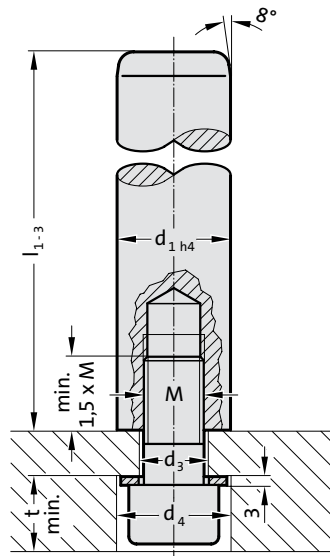

Material:

Steel, surface hardened
 Surface hardness: 60 + 3 HRC, Hardness penetration $\geq 1,8$ mm

Execution:

ground

Note:

Guide pillars only recommended for use with sliding guides!

 Matching guide combinations, see selection matrix at the beginning of chapter D.

Hole pattern for column (pillar) fastening

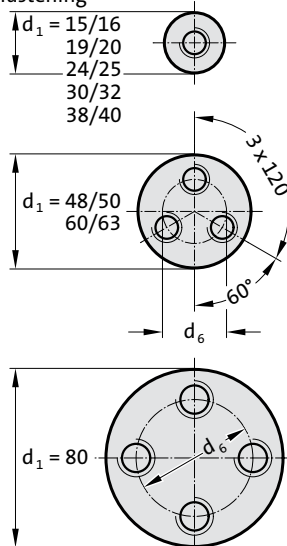

GUIDE PILLAR ECO-LINE ENDWISE BOLT-ON TYPE, ~DIN 9825/~ISO 9182-2

202.31. Guide pillar ECO-LINE endwise bolt-on type, ~DIN 9825/~ISO 9182-2

d ₁	15 16	19 20	24 25	30 32	38 40	48 50	60 63	80
d ₃	9	11	14	18	18	14	18	18
d ₄	17	20	22	28	28	22	28	28
d ₆	-	-	-	-	-	28	34	54
t	12	14	16	20.5	20.5	16	20.5	20.5
M	8	10	12	16	16	12	16	16
Screw	M8x35	M10x40	M12x40	M16x40	M16x40	M12x50	M16x60	M16x60
Tightening torque [Nm]	21	37	85	150	150	85	200	200
l ₁								
90	●							
100	●	●	●					
112	●	●	●					
125	●	●	●	●				
140	●	●	●	●				
160	●	●	●	●	●			
180	●	●	●	●	●	●		
200	●	●	●	●	●	●		
224	●	●	●	●	●	●		
250	●	●	●	●	●	●	●	
280	●	●	●	●	●	●	●	●
315	●	●	●	●	●	●	●	●
355	●	●	●	●	●	●	●	●
400		●	●	●	●	●	●	●
450			●	●	●	●	●	●
500			●	●	●	●	●	●
550					●	●	●	●
600					●	●	●	●
700					●	●	●	●
800					●	●	●	●

Ordering Code (example):

Guide pillar ECO-LINE endwise bolt-on type, ~DIN 9825/~ISO 9182-2		= 202.31.
Diameter of conduit d ₁	48 mm	= 032.
Length l ₁	550 mm	= 125
Order No		= 202.31. 032. 125

GUIDE PILLAR, CONICAL, DIN 9825/ISO 9182-4/AFNOR



2021.50.

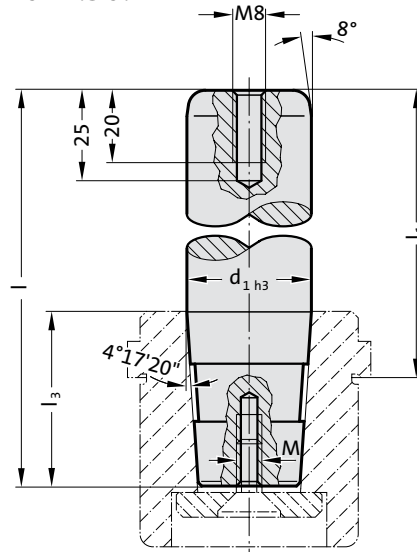

Description:

FIBRO demountable pillars with conical shaft 2021.50. are recommended where die sharpening etc. demands frequent demounting and re-fitting.

Material:

Steel, (Core strength: $\geq 900 \text{ N/mm}^2$) surface hardened

Surface hardness: $60 + 3 \text{ HRC}$, Hardness penetration $\geq 1,8 \text{ mm}$

Execution:

fine-ground and superfinished

Method of manufacturing entails that centre holes are not concentric with O.D.

Note:

Matching retaining bushes 2021.39./210.39. and retaining discs 2021.53./202.53. to be ordered separately.

 Preloading see pairing classification at the beginning of chapter D

 Matching guide combinations, see selection matrix at the beginning of chapter D.

Tolerance range:

yellow = .10

green = .20

red = .30

Mounting example

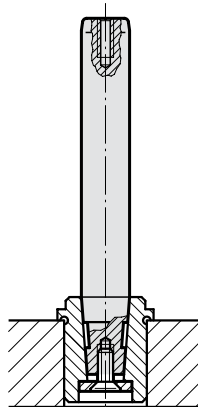

GUIDE PILLAR, CONICAL, DIN 9825/ISO 9182-4/AFNOR

2021.50. Guide pillar, conical, DIN 9825/ISO 9182-4/AFNOR

d ₁	16	19 20	24 25	25	30 32	32	38 40	40	48 50	50	60 63	63	63
d ₆	22	22	25	25	32	32	40	40	50	50	63	63	63
M	6	6	8	8	8	8	8	8	10	10	12	12	12
l ₃	28	38	35	45	48	61	48	61	58	78	69	77	97
l ₁	1												
82	100												
95	113												
100		126	123										
112	130	138	135		145								
125	143	151	148	158	158		158						
140		166	163		173	186	173		180				
160		186	183	193	193	206	193	206	200		211		
180		206	203	213	213	226	213	226	220		231	237	
200		226	223	233	233		233		240	260	251	257	
224			247		257	270	257	270	264		275		
250			273		283		283	296	290	310	301	307	327
280					313		313		320	340	331	337	
315							348		355	375	366	372	392
355									395		406		432
400													477

Ordering Code (example):

Guide pillar, conical, DIN 9825/ISO 9182-4/AFNOR	=	2021.50.
Diameter of conduit d ₁	38 mm =	038.
Guide length l ₁	180 mm =	180.
Cone length l ₃	48 mm =	048.
Classification TOL	yellow =	10
Order No	=	2021.50. 038. 180. 048. 10

DEMOUNTABLE GUIDE PILLAR, CONICAL, WITH BALL CAGE RETAINER, DIN 9825/ISO 9182-4/AFNOR



2021.58.

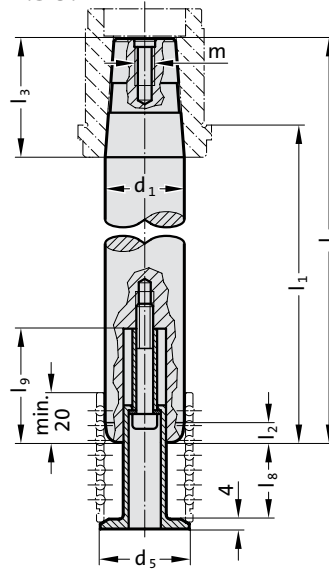

Description:

FIBRO demountable pillars with conical shaft 2021.58. are recommended where die sharpening etc. demands frequent demounting and re-fitting.

Material:

Steel, (Core strength: $\geq 900 \text{ N/mm}^2$) surface hardened

Surface hardness: $60 + 3 \text{ HRC}$, Hardness penetration $\geq 1,8 \text{ mm}$

Execution:

fine-ground and superfinished

Note:

Matching retaining bushes 2021.39./210.39. and retaining discs 2021.53./202.53. to be ordered separately.

 Preloading see pairing classification at the beginning of chapter D

 Matching guide combinations, see selection matrix at the beginning of chapter D.

Dimensions of ball cage retainer see 202.91.

Tolerance range:

yellow = .10

green = .20

red = .30

Mounting example

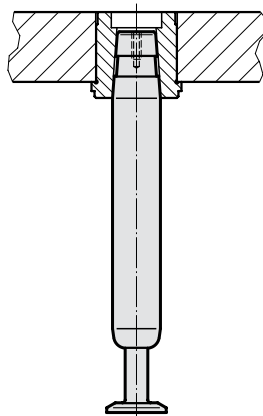

DEMOUNTABLE GUIDE PILLAR, CONICAL, WITH BALL CAGE RETAINER, DIN 9825/ISO 9182-4/AFNOR

2021.58. Demountable guide pillar, conical, with ball cage retainer, DIN 9825/ISO 9182-4/AFNOR

d ₁	38	40	40	48	50	50	60	63	63	63
d ₅	42	44	44	52	54	54	64	67	67	67
m	8	8	8	10	10	10	12	12	12	12
l ₃	48	48	61	58	58	78	69	69	77	97
KG (l ₈ / l ₉)										
1 (31 / 46)	●	●	●	●	●	●	●	●	●	●
2 (41 / 56)	●	●	●	●	●	●	●	●	●	●
3 (51 / 66)	●	●	●	●	●	●	●	●	●	●
4 (61 / 76)	●	●	●	●	●	●	●	●	●	●
5 (73 / 89)	●	●	●	●	●	●	●	●	●	●
l ₁	1									
125	158	158								
140	173	173		180	180					
160	193	193	206	200	200		211	211		
180	213	213	226	220	220		231	231	237	
200	233	233		240	240	260	251	251	257	
224	257	257	270	264	264		275	275		
250	283	283	296	290	290	310	301	301	307	327
280	313	313		320	320	340	331	331	337	
315	348	348		355	355	375	366	366	372	392
355				395	395		406	406		432
400										477

Ordering Code (example):

Demountable guide pillar, conical, with ball cage retainer, DIN 9825/ISO 9182-4/AFNOR		= 2021.58.
Diameter of conduit d ₁	50 mm	= 050.
Guide length l ₁	200 mm	= 200.
Cone length l ₃	58 mm	= 058.
Cage unit size KG	1	= 1
Classification TOL	yellow	= 1
Order No		= 2021.58. 050. 200. 058. 1 1

RETAINING DISC WITH COUNTERSUNK HEAD CAP SCREW, DIN 9825/ISO 9182-4 RETAINING DISC WITH SOCKET CAP SCREW, ~AFNOR



Mounting example

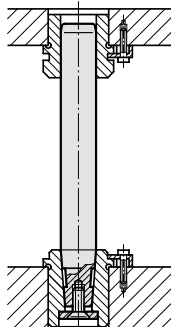

2021.53.

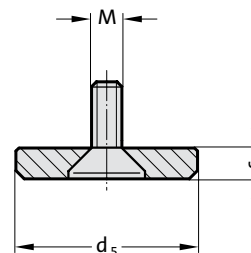

Material:

Retaining disc: Steel, burnished
Countersunk head cap screw DIN 7991/ISO 10642

Note:

Has to be ordered separately to guide pillar, conical according to DIN 9825 / ISO 9182-4 2021.50. or 2021.58.

2021.53. Retaining disc with countersunk head cap screw, DIN 9825/ISO 9182-4

Order No	Nominal-ø	Pillar-ø	d ₅	s	M
2021.53.020	20	19/20	22	3	M6
2021.53.025	25	24/25	25	3	M8
2021.53.032	32	30/32	32	3	M8
2021.53.040	40	38/40	40	5	M8
2021.53.050	50	48/50	50	5	M10
2021.53.063	63	60/63	63	6	M12



Mounting example

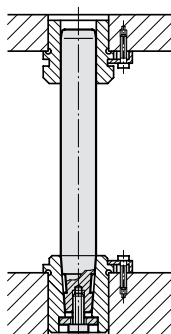

202.53.

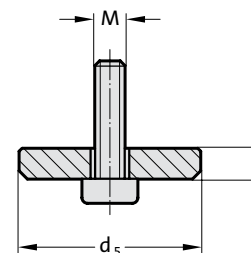

Material:

Retaining disc: Steel, burnished
Socket head cap screw DIN 6912

Note:

Has to be ordered separately to guide pillar, conical according to AFNOR 2021.50. or 2021.58.

202.53. Retaining disc with socket cap screw, ~AFNOR

Order No	Pillar-ø	d ₅	s	M
202.53.016	16	18	3	M6
202.53.020	20	22	3	M6
202.53.025	25	25	4	M8
202.53.032	32	32	4	M8
202.53.040	40	40	4	M8
202.53.050	50	50	5	M10
202.53.063	63	63	6	M12

GUIDE PILLAR WITH 5° PILOT TAPER, TO VW-STANDARD



Mounting example

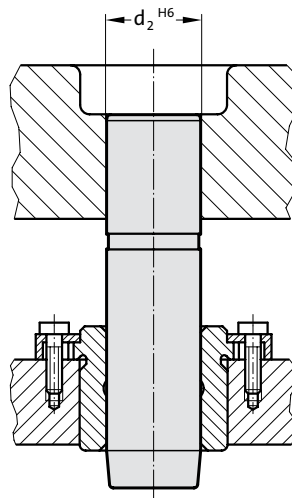

2022.13.

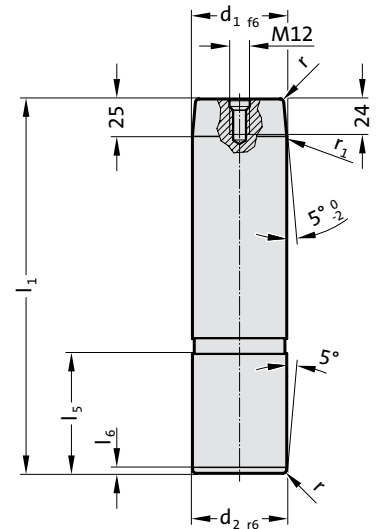

Material:

Steel, surface hardened
 Surface hardness: 60 + 4 HRC, Hardness penetration 1,5 + 1 mm

Execution:

precision ground
 ø d₁ = 80 with 1 lifting thread M12

Note:

Guide pillar is recommended to be used only with guide elements with solid lubricant.

☞ Matching guide combinations, see selection matrix at the beginning of chapter D.

☞ Assembly guide lines / Dimensional requirements and tolerances at the end of chapter D.

Application:

Floating support in upper half of trimming tools.

2022.13. Guide pillar with 5° pilot taper, to VW-Standard

	40	50	63	80
d ₁	40	50	63	80
d ₂	40	50	63	80
l ₅	56	70	80	100
l ₆	4	4	4	4
r	2	2,5	2,5	3
r ₁	3	5	6	8
l ₁				
140	●			
160	●	●		
180	●	●	●	
200	●	●	●	
224	●	●	●	●
250	●	●	●	●
280	●	●	●	●
315		●	●	●
355		●	●	●
400			●	●

Ordering Code (example):

Guide pillar with 5° pilot taper, to VW-Standard	=	2022.13.
Diameter of conduit d ₁	63 mm =	063.
Length l ₁	180 mm =	180
Order No	=	2022.13. 063. 180

GUIDE PILLAR WITH PILOT TAPPER, VDI 3356

2022.15.

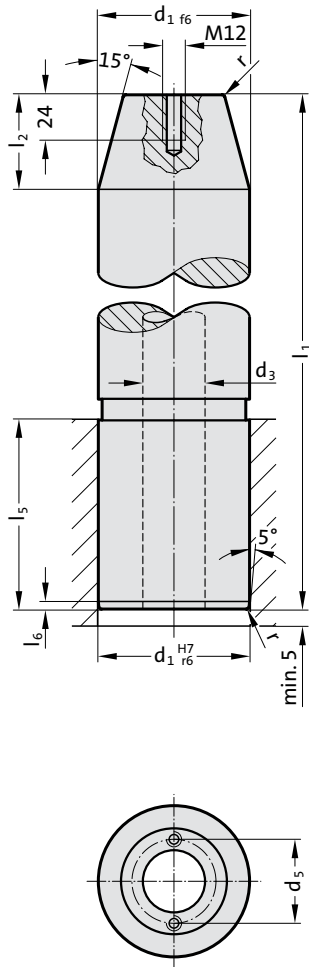

Material:

Steel, surface hardened

Surface hardness: 60 + 4 HRC, Hardness penetration 1,5 + 1 mm

Execution:

ground

ø d₁ = 80 without central hole with 1 lifting thread M12

from ø d₁ = 100 with central hole (through) and with 2 lifting threads M8

Note:

Guide pillar is recommended to be used only with guide elements with solid lubricant.

☞ Matching guide combinations, see selection matrix at the beginning of chapter D.

☞ Assembly guide lines / Dimensional requirements and tolerances at the end of chapter D.

2022.15. Guide pillar with pilot taper, VDI 3356

d ₁	80	100	125	160
d ₃	-	50	65	95
d ₅	-	62	82	119
r	3	3	4	4
l ₂	50	50	50	50
l ₅	100	125	140	180
l ₆	4	4	5	5
l ₁				
280	●			
315		●		
355	●	●	●	
400	●	●	●	
450	●	●	●	●
500			●	●
560				●

Ordering Code (example):

Guide pillar with pilot taper, VDI 3356	= 2022.15.
Diameter of conduit d ₁	125 mm = 125.
Length l ₁	355 mm = 355
Order No	= 2022.15. 125. 355

GUIDE PILLAR WITH GROOVE, TO VW



2022.17.

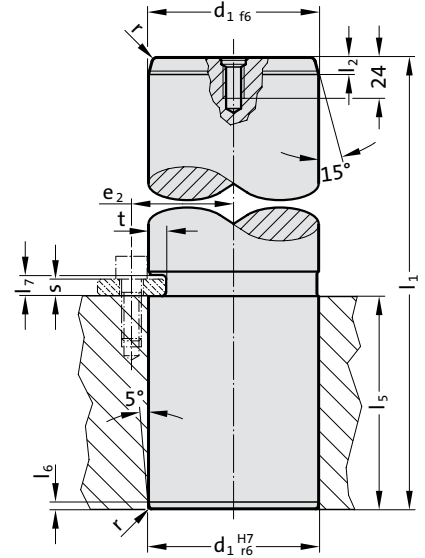

Material:

Steel, surface hardened
 Surface hardness: 60 + 4 HRC, Hardness penetration 1,5 + 1 mm

Execution:

ground
 ø d₁ = 80 with 1 lifting thread M12

Note:

Secure with locating plate 2022.40.1.
 Guide pillar is recommended to be used only with guide elements with solid lubricant.

☞ Matching guide combinations, see selection matrix at the beginning of chapter D.

☞ Assembly guide lines / Dimensional requirements and tolerances at the end of chapter D.

2022.17. Guide pillar with groove, to VW

	25	32	40	50	63	80
d ₁	25	32	40	50	63	80
l ₂	8	8	8	10	10	10
l ₅	40	45	56	70	80	100
l ₆	4	4	4	4	4	4
l ₇	7	7	10	10	12	12
r	2	2	2	2.5	2.5	3
e ₂	20.5	24	29.5	33.5	43	50
t	3	3	4	4	6.5	8
l ₁						
125	●	●				
140	●	●	●			
160	●	●	●	●		
180	●	●	●	●	●	
200	●	●	●	●	●	
224	●	●	●	●	●	●
250		●	●	●	●	●
280			●	●	●	●
315				●	●	●
355				●	●	●
400					●	●
450						●
500						●

Ordering Code (example):

Guide pillar with groove, to VW	=	2022.17.
Diameter of conduit d ₁	50 mm	= 050.
Length l ₁	160 mm	= 160
Order No	=	2022.17. 050. 160

LOCATING PLATE FOR GUIDE PILLAR, TO VW

2022.40.1.

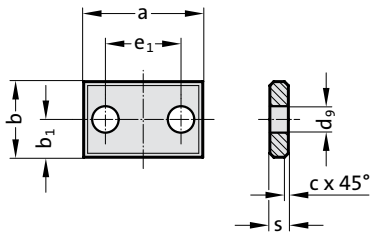

2022.40.1. Locating plate for guide pillar, to VW

Order No	Pillar- \varnothing	a	b	s	c	b ₁	e ₁	d ₉
2022.40.1.02	25/32	40	20	5	1	10	20	9
2022.40.1.04	40/50	48	25	8	2	12.5	24	11
2022.40.1.06	63/80	60	34	10	2	17	30	14

Material:

Steel

Note:

Screws are not included.

Fixing:

Use socket cap screws DIN EN ISO 4762.

Ordering Code (example):

Locating plate for guide pillar, to VW	=	2022.40.1.
Nominal size NENN	04 =	04
Order No	=	2022.40.1. 04

GUIDE PILLAR WITH RETAINING RING GROOVE, ~AFNOR

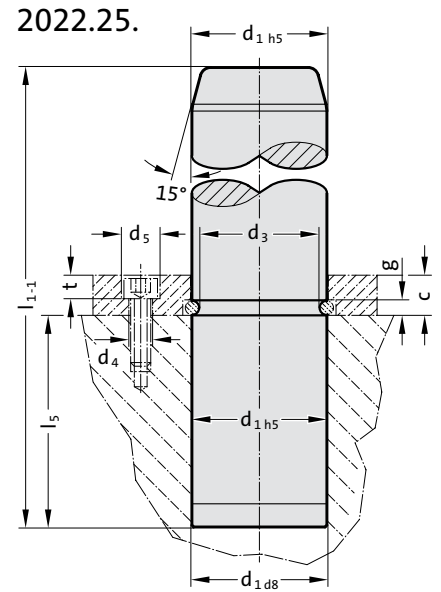

Material:

Steel, surface hardened
 Surface hardness: 60 + 4 HRC, Hardness penetration 1,5 + 1 mm

Execution:

ground

Note:

Guide pillar is recommended to be used only with guide elements with solid lubricant.

☞ Matching guide combinations, see selection matrix at the beginning of chapter D.

☞ Assembly guide lines / Dimensional requirements and tolerances at the end of chapter D.

Fixing:

Clamping flange with retaining ring, without screws, 2073.46.□□□ order separately.

2022.25. Guide pillar with retaining ring groove, ~AFNOR

d ₁	25	32	40	50	63	80	100
d ₃	22.3	27.8	35.8	45.8	56.8	73.8	93.8
g	2.7	4.2	4.2	4.2	6.2	6.2	6.2
l ₅	25	32	63	80	100	125	160
l ₁							
100	●						
125	●	●					
140	●	●					
160	●	●					
180	●	●	●				
200	●	●	●	●			
220	●	●	●	●	●		
250		●	●	●	●	●	
280			●	●	●	●	
315			●	●	●	●	●
355				●	●	●	●
400				●	●	●	●
450					●	●	●
500					●	●	●

Ordering Code (example):

Guide pillar with retaining ring groove, ~AFNOR	=	2022.25.
Diameter of conduit d ₁	50 mm =	050.
Length l ₁	220 mm =	220
Order No	=	2022.25. 050. 220

GUIDE PILLAR WITH SNAP RING GROOVE, TO MERCEDES-BENZ STANDARD

2022.16.



Material:

Steel, surface hardened
 Surface hardness: 60 + 4 HRC, Hardness penetration 1,5 + 1 mm

Execution:

ground
 up to $\varnothing d_1 = 80$ without central hole
 by $\varnothing d_1 = 80$ with 1 lifting thread M12
 from $\varnothing d_1 = 100$ with central hole (through) and with 2 lifting threads M12

Note:

Secure with snap ring 2061.48.
 Guide pillar is recommended to be used only with guide elements with solid lubricant.
 ☞ Matching guide combinations, see selection matrix at the beginning of chapter D.
 ☞ Assembly guide lines / Dimensional requirements and tolerances at the end of chapter D.

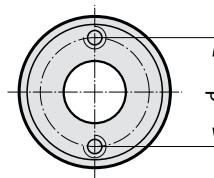
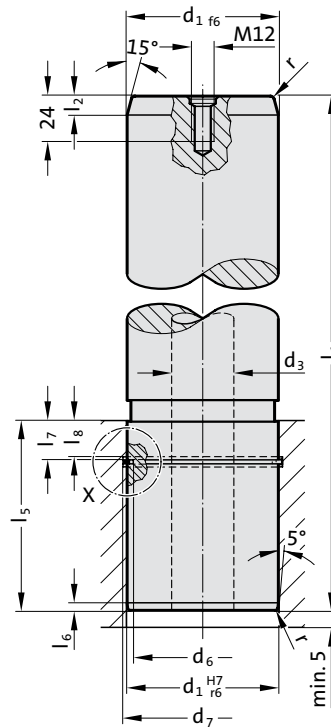

Mounting example

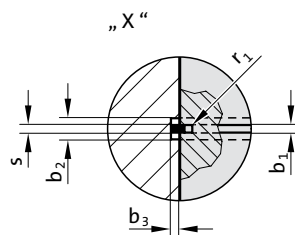

GUIDE PILLAR WITH SNAP RING GROOVE, TO MERCEDES-BENZ STANDARD

2022.16. Guide pillar with snap ring groove, to Mercedes-Benz Standard

d ₁	40	50	63	80	100	125	160
d ₃	-	-	-	-	50	65	95
d ₅	-	-	-	-	72	90	132
d ₆	33	43	55.7	71.4	89.9	114.9	148.9
r	2	2.5	2.5	3	3	4	4
r ₁	1	1	1	1.05	1.3	1.3	1.3
l ₂	8	10	10	10	10	12	12
l ₅	56	70	80	100	125	140	180
l ₆	4	4	4	4	4	5	5
l ₇	15	15	15	21	31	31	31
l ₈	14	14	14	20	30	30	30
b ₁	2	2	2	2.1	2.6	2.6	2.6
b ₂	3.2	3.2	3.2	4.2	5.2	5.2	5.2
l ₁							
140	●						
160	●	●					
180	●	●	●				
200	●	●	●				
224	●	●	●	●			
250	●	●	●	●	●		
280	●	●	●	●	●	●	
315		●	●	●	●	●	●
355		●	●	●	●	●	●
400			●	●	●	●	●
450				●	●	●	●
500				●	●	●	●
560							●

Ordering Code (example):

Guide pillar with snap ring groove,
to Mercedes-Benz Standard = 2022.16.
Diameter of conduit d₁ 80 mm = 080.
Length l₁ 224 mm = 224
Order No = 2022.16. 080. 224

GUIDE PILLAR WITH PILOT TAPPER AND GROOVE, TO MERCEDES-BENZ STANDARD



Mounting example

2022.12.

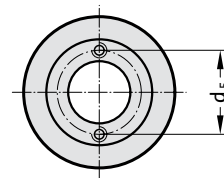
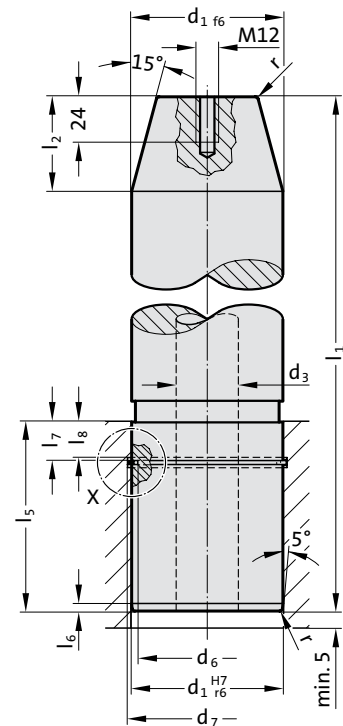
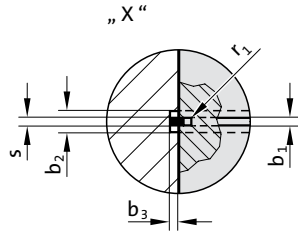

Material:

Steel, surface hardened

Surface hardness: 60 + 4 HRC, Hardness penetration 1,5 + 1 mm

Execution:

ground

$\varnothing d_1 = 80$ without central hole with 1 lifting thread M12

from $\varnothing d_1 = 100$ with central hole (through) and with 2 lifting threads M8

Note:

Secure with snap ring 2061.48.

Guide pillar is recommended to be used only with guide elements with solid lubricant.

☞ Matching guide combinations, see selection matrix at the beginning of chapter D.

☞ Assembly guide lines / Dimensional requirements and tolerances at the end of chapter D.

2022.12. Guide pillar with pilot taper and groove, to Mercedes-Benz Standard

d_1	80	100	125	160
d_3	-	50	65	95
d_5	-	62	82	119
d_6	71.4	89.9	114.9	148.9
r	3	3	4	4
r_1	1.05	1.3	1.3	1.3
l_2	50	50	50	50
l_5	100	125	140	180
l_6	4	4	5	5
l_7	21	31	31	31
l_8	20	30	30	30
b_1	2.1	2.6	2.6	2.6
b_2	4.2	5.2	5.2	5.2
l_1				
280	●			
315	●	●		
355	●	●	●	
400	●	●	●	
450	●	●	●	
500			●	●
560				●

Ordering Code (example):

Guide pillar with pilot taper and groove,
to Mercedes-Benz Standard

= 2022.12.

Diameter of conduit d_1 125 mm = 125.

Length l_1 355 mm = 355

Order No = 2022.12. 125. 355

GUIDE PILLAR WITH GROOVE, TO CNOMO



Mounting example

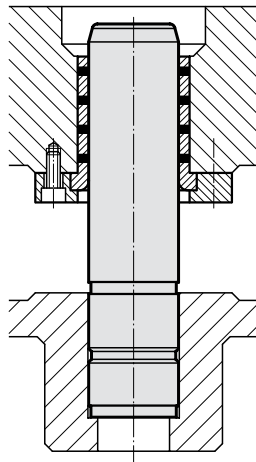

2022.16.45.

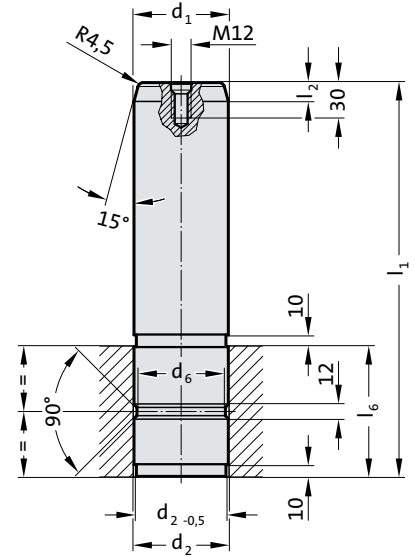

Material:

Steel, surface hardened
Surface hardness: 60 + 3 HRC, Hardness penetration 2 + 1,6 mm

Execution:

precision ground

Note:

Fit for receiving bore H7.
Guide pillar is recommended to be used only with guide elements with solid lubricant.
☞ Matching guide combinations, see selection matrix at the beginning of chapter D.

2022.16.45. Guide pillar with groove, to CNOMO

d ₁	80	100
Tolerance	-0,010/-0,025	-0,010/-0,025
d ₂	80	100
Tolerance	+0,04/+0,05	+0,045/+0,055
d ₆	75	95
l ₂	16	16
l ₆	110	140
l ₁		
350	●	
400	●	●
450		●

Ordering Code (example):

Guide pillar with groove, to CNOMO	=	2022.16.45.
Diameter of conduit d ₁	100 mm =	100.
Length l ₁	400 mm =	400
Order No	=	2022.16.45. 100.400

GUIDE PILLAR WITH GROOVE

2022.16.48.

Mounting example

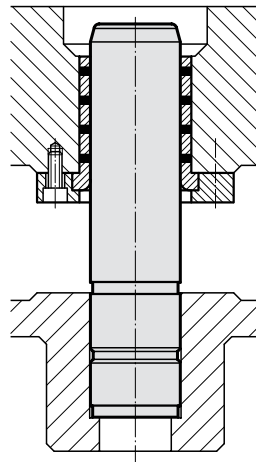
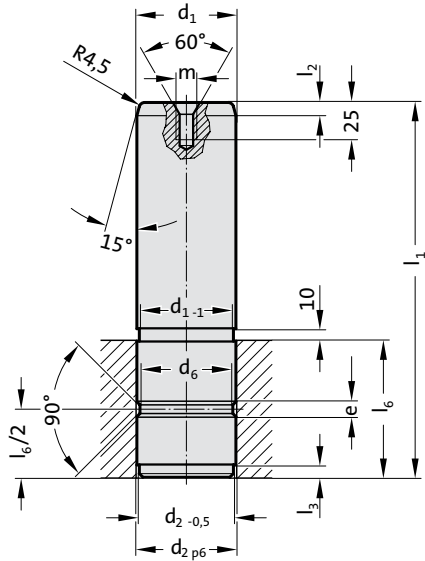

Material:

Steel, surface hardened
Surface hardness: 55 + 5 HRC, Hardness penetration 2 + 1,6 mm

Execution:

precision ground

Note:

Fit for receiving bore H7.
Guide pillar is recommended to be used only with guide elements with solid lubricant.
☞ Matching guide combinations, see selection matrix at the beginning of chapter D.

2022.16.48. Guide pillar with groove

d ₁	25	30	40	50	60	65	80	100
Tolerance	-0,005/-0,015	-0,005/-0,015	-0,005/-0,015	-0,005/-0,015	-0,01/-0,02	-0,01/-0,02	-0,01/-0,025	-0,01/-0,025
d ₂	25	30	40	50	60	65	80	100
Tolerance	+0,022/+0,035	+0,022/+0,035	+0,026/+0,042	+0,026/+0,042	+0,032/+0,051	+0,032/+0,051	+0,032/+0,051	+0,037/+0,059
d ₆	21	26	36	45	55	60	75	95
l ₂	5	5	5	10	10	10	10	10
l ₃	5	5	5	10	10	10	10	10
l ₆	30	40	50	70	90	100	120	150
m	M8	M8	M8	M12	M12	M12	M12	M12
l ₁								
80	●							
100	●	●						
120	●	●	●					
140		●	●					
160		●	●	●				
180		●	●	●	●			
200			●	●	●			
220					●			
250				●	●	●	●	
300				●	●	●	●	●
350					●	●	●	●
400						●	●	●

Ordering Code (example):

Guide pillar with groove	=	2022.16.48.
Diameter of conduit d ₁	60 mm	= 060.
Length l ₁	200 mm	= 200
Order No	=	2022.16.48. 060. 200

GUIDE PILLAR WITH COLLAR, TO WDX



Mounting example

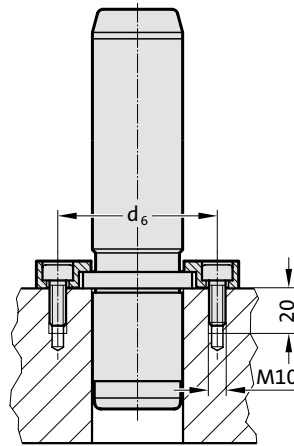

2022.29.

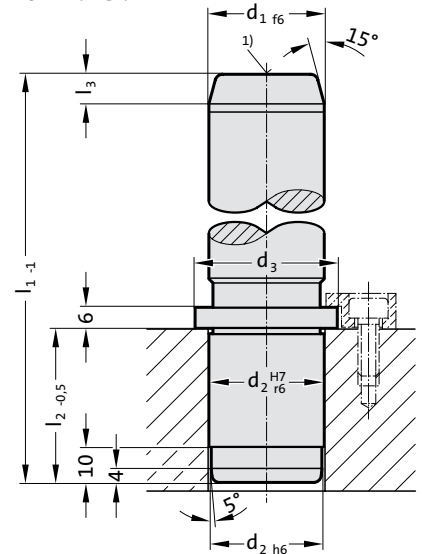

Material:

Steel, surface hardened
 Surface hardness: 60 + 4 HRC, Hardness penetration 1,5 + 1 mm

Execution:

precision ground
 Method of manufacturing entails that centre holes are not concentric with O.D.

1) from $\varnothing d_1 = 80$ - with thread M12x18 deep

Note:

Guide pillar is recommended to be used only with guide elements with solid lubricant.

☞ Matching guide combinations, see selection matrix at the beginning of chapter D.

☞ Assembly guide lines / Dimensional requirements and tolerances at the end of chapter D.

Order No. for guide pillar with collar, to WDX, with screw clamps:
 2022.29.□□□.□□□.A

Fixing:

(to be ordered separately)
 Screw clamps with screws 2072.46 (M10 x 20 DIN EN ISO 4762)
 up to $\varnothing d_1 = 50$ - 2 screw clamps
 from $\varnothing d_1 = 63$ - 3 screw clamps

2022.29. Guide pillar with collar, to WDX

d_1	25	32	40	50	63	80	100
d_2	25	32	40	50	63	80	100
d_3	32	40	50	60	80	90	110
d_6	68	75	83	93	106	123	143
l_2	40	42	56	70	80	100	125
l_3	6	8	8	10	10	10	10
l_1							
125	●						
140	●	●					
160	●	●	●	●			
180	●	●	●	●			
200	●	●	●	●	●		
224	●	●	●	●	●	●	
250		●	●	●	●	●	
280			●	●	●	●	
315				●	●	●	●
355					●	●	●
400					●	●	●
500						●	●

Ordering Code (example):

Guide pillar with collar, to WDX	=	2022.29.
Diameter of conduit d_1	50 mm =	050.
Length l_1	160 mm =	160
Order No	=	2022.29. 050. 160

GUIDE PILLAR WITH COLLAR, SCREW CLAMP RETENTION, DIN 9825/~ISO 9182-5



2021.46.

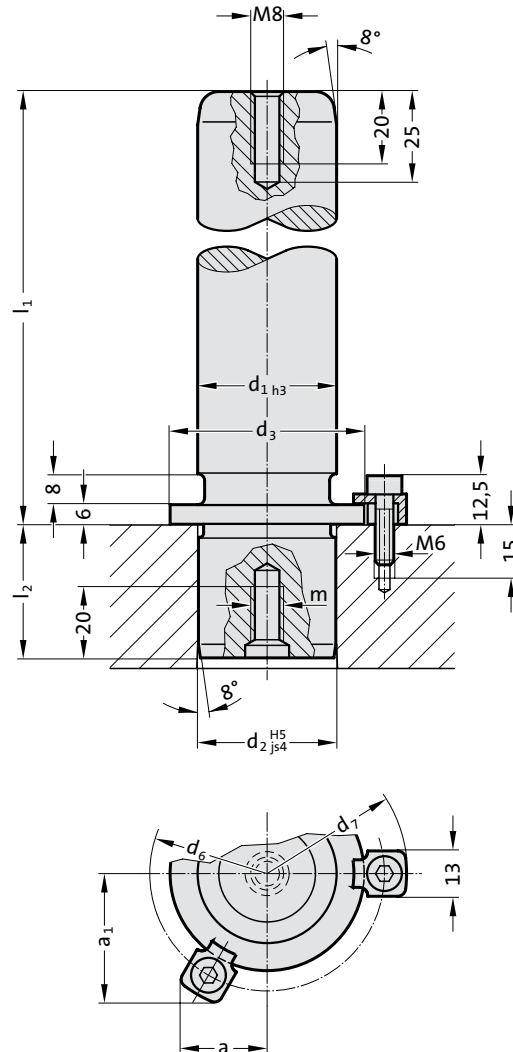

Description:

Demountable pillars with shoulder are suited to applications where die sharpening requires dismantling and re-fitting.

Material:

Steel, (Core strength: $\geq 900 \text{ N/mm}^2$) surface hardened

Surface hardness: $60 + 3 \text{ HRC}$, Hardness penetration $\geq 1,8 \text{ mm}$

Execution:

fine precision ground

Method of manufacturing entails that centre holes are not concentric with O.D.

Note:

The attachment is with 3 Screw clamp, from $\varnothing d_1 = 38$ with 4 Screw clamp, which are included in delivery (Order No: 207.45 - Screw clamp incl. socket cap screw DIN 6912, M6x20, Head $\varnothing 13$).

Optionally, it is also possible to fix it with a central screw connection 2021.43. or supporting ring 2021.45. (order separately).

Bearing clearance / Preloading see pairing classification at the beginning of chapter D.

Matching guide combinations, see selection matrix at the beginning of chapter D.

Assembly guide lines / Dimensional requirements and tolerances at the end of chapter D.

Tolerance range:

yellow = .10

green = .20

red = .30

Mounting example

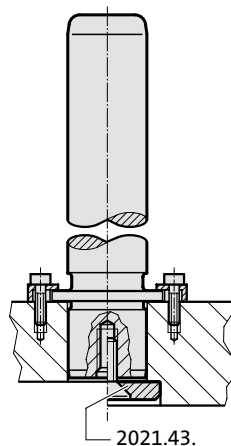

GUIDE PILLAR WITH COLLAR, SCREW CLAMP RETENTION, DIN 9825/~ISO 9182-5

2021.46. Guide pillar with collar, screw clamp retention, DIN 9825/~ISO 9182-5

d ₁	15 16	19 20	24 25	30 32	38 40	48 50	60 63	80
d ₂	15 16	19 20	24 25	30 32	38 40	48 50	60 63	80
d ₃	22	25	32	40	50	63	80	95
d ₆	33	36	43	51	61	74	91	106
d ₇	45.7	48.7	55.7	63.7	73.7	86.7	103.7	118.7
a	15.9	16.6	18.4	20.4	29.2	33.8	39.8	46.2
a ₁	21.7	23	26	29.5	29.2	33.8	39.8	46.2
m	8	8	8	8	8	8	8	12
l ₂	20	23	30	37	37	47	47	60
l ₁								
100	●	●	●					
112	●	●	●	●				
125	●	●	●	●	●			
140	●	●	●	●	●	●		
160	●	●	●	●	●	●	●	
180	●	●	●	●	●	●	●	
200	●	●	●	●	●	●	●	●
224			●	●	●	●	●	●
250			●	●	●	●	●	●
280				●	●	●	●	●
315				●	●	●	●	●
355					●	●	●	●
400						●	●	●

Ordering Code (example):

Guide pillar with collar, screw clamp retention, DIN 9825/~ISO 9182-5		= 2021.46.
Diameter of conduit d ₁	32 mm	= 032.
Length l ₁	315 mm	= 315.
Classification TOL	yellow	= 10
Order No		= 2021.46. 032. 315. 10

GUIDE PILLAR WITH COLLAR AND BALL CAGE RETAINER



2021.44.

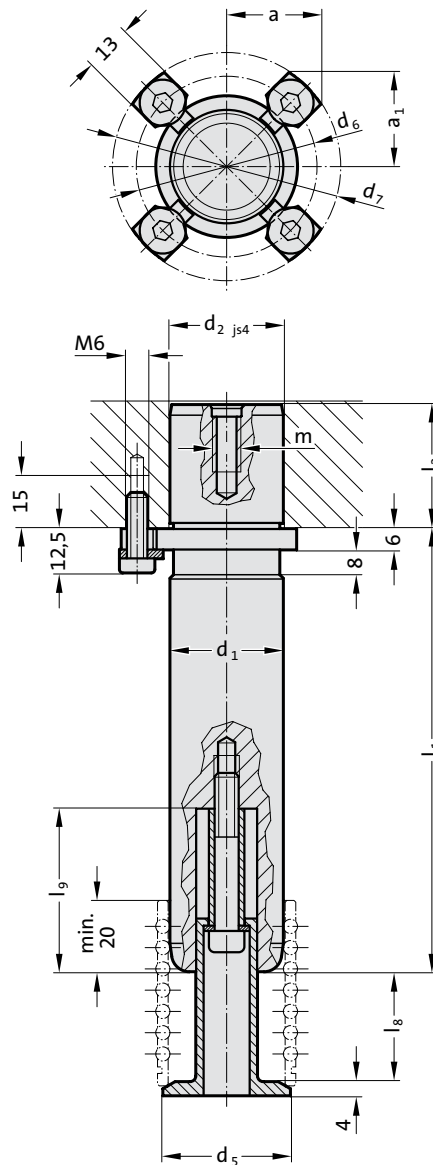

Description:

Demountable pillars with shoulder are suited to applications where die sharpening requires dismantling and re-fitting.

Material:

Steel, (Core strength: $\geq 900 \text{ N/mm}^2$) surface hardened

Surface hardness: $60 + 3 \text{ HRC}$, Hardness penetration $\geq 1,8 \text{ mm}$

Execution:

fine precision ground

Note:

The attachment is with 3 Screw clamp, from $\varnothing d_1 = 38$ with 4 Screw clamp, which are included in delivery (Order No: 207.45 - Screw clamp incl. socket cap screw DIN 6912, M6x20, Head $\varnothing 13$).

Optionally, it is also possible to fix it with a central screw connection 2021.43. or supporting ring 2021.45. (order separately).

☞ Preloading see pairing classification at the beginning of chapter D

☞ Matching guide combinations, see selection matrix at the beginning of chapter D.

☞ Assembly guide lines / Dimensional requirements and tolerances at the end of chapter D.

Dimensions of ball cage retainer see 202.91.

Tolerance range:

yellow = .10

green = .20

red = .30

Mounting example

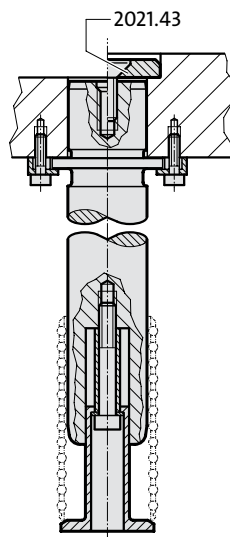

GUIDE PILLAR WITH COLLAR AND BALL CAGE RETAINER

2021.44. Guide pillar with collar and ball cage retainer

d ₁	38	40	48	50	60	63
d ₂	38	40	48	50	60	63
d ₃	50	50	63	63	80	80
d ₅	42	44	52	54	64	67
d ₆	61	61	74	74	91	91
d ₇	73.7	73.7	86.7	86.7	103.7	103.7
a	29.2	29.2	33.8	33.8	39.8	39.8
a ₁	29.2	29.2	33.8	33.8	39.8	39.8
m	M8	M8	M8	M8	M8	M8
l ₂	37	37	47	47	47	47
KG (l _g / l _g)						
1 (31 / 46)	●	●	●	●	●	●
2 (41 / 56)	●	●	●	●	●	●
3 (51 / 66)	●	●	●	●	●	●
4 (61 / 76)	●	●	●	●	●	●
5 (73 / 89)	●	●	●	●	●	●
l ₁						
125	●	●				
140	●	●	●	●		
160	●	●	●	●	●	●
180	●	●	●	●	●	●
200	●	●	●	●	●	●
224	●	●	●	●	●	●
250	●	●	●	●	●	●
280	●	●	●	●	●	●
315	●	●	●	●	●	●
355	●	●	●	●	●	●
400			●	●	●	●

Ordering Code (example):

Guide pillar with collar and ball cage retainer		=	2021.44.
Diameter of conduit d ₁	48 mm	=	048.
Length l ₁	400 mm	=	400.
Cage unit size KG	1	=	1.
Classification TOL	yellow	=	10
Order No		=	2021.44. 048. 400. 1. 10

GUIDE PILLAR WITH COLLAR, WITH CAGE UNIT BORE

2021.46. .30.94

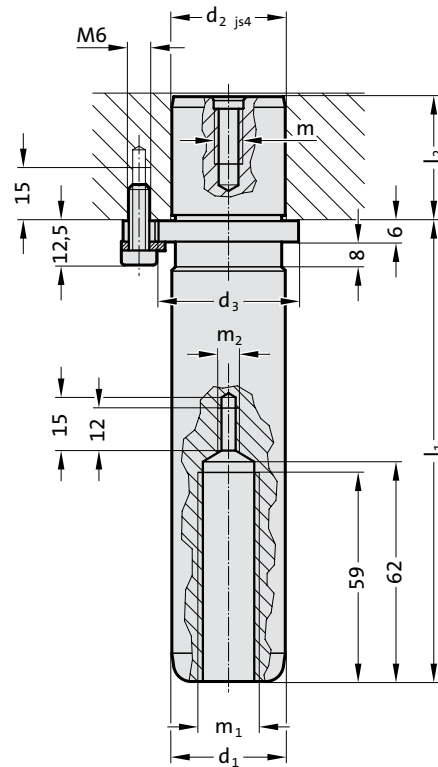
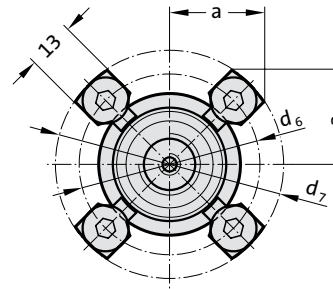

Description:

Demountable pillars with shoulder are suited to applications where die sharpening requires dismantling and re-fitting.

Material:

Steel, (Core strength: $\geq 900 \text{ N/mm}^2$) surface hardened

Surface hardness: $60 + 3 \text{ HRC}$, Hardness penetration $\geq 1,8 \text{ mm}$

Execution:

fine precision ground

Note:

The attachment is with 3 Screw clamp, from $\varnothing d_1 = 38$ with 4 Screw clamp, which are included in delivery (Order No: 207.45 - Screw clamp incl. socket cap screw DIN 6912, M6x20, Head $\varnothing 13$).

Optionally, it is also possible to fix it with a central screw connection 2021.43. or supporting ring 2021.45. (order separately).

☞ Preloading see pairing classification at the beginning of chapter D

☞ Matching guide combinations, see selection matrix at the beginning of chapter D.

☞ Assembly guide lines / Dimensional requirements and tolerances at the end of chapter D.

Dimensions of ball cage retainer see 202.94.

Tolerance range: red = .30

Delivery without cage retainer, ball cage and head cap screw.

Mounting example

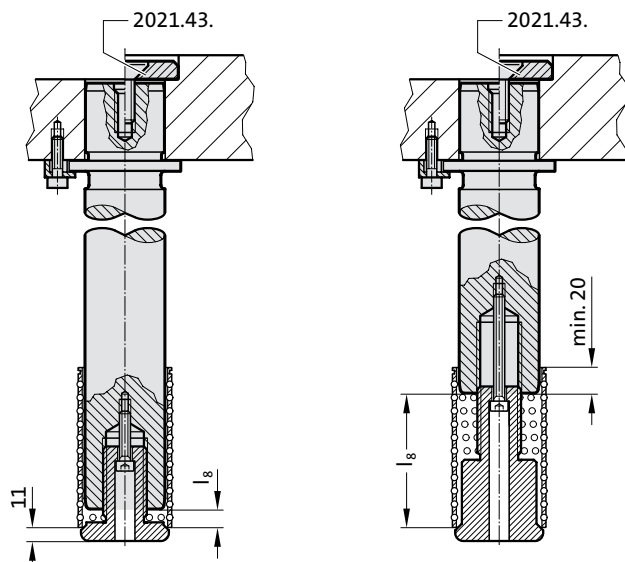

GUIDE PILLAR WITH COLLAR, WITH CAGE UNIT BORE

2021.46. .30.94 Guide pillar with collar, with cage unit bore

d ₁	30 32	38 40	48 50	60 63	80
d ₂	30 32	38 40	48 50	60 63	80
d ₃	40	50	63	80	95
d ₆	51	61	74	91	106
d ₇	63.7	73.7	86.7	103.7	118.7
a	20.4	29.2	33.8	39.8	46.2
a ₁	29.5	29.2	33.8	39.8	46.2
m ₁	M16x1,5	M16x1,5	M20x1,5	M30x1,5	M30x1,5
m ₂	M5	M5	M6	M8	M8
l ₂	37	37	47	47	60
l ₁					
112	●				
125	●	●			
140	●	●	●		
160	●	●	●	●	
180	●	●	●	●	
200	●	●	●	●	●
224	●	●	●	●	●
250	●	●	●	●	●
280	●	●	●	●	●
315	●	●	●	●	●
355		●	●	●	●
400			●	●	●

Ordering Code (example):

Guide pillar with collar, with cage unit bore		=	2021.46.
Diameter of conduit d ₁	48 mm	=	048.
Length l ₁	180 mm	=	180.
Classification red TOL	30	=	30.
Cage unit bore KHB	94	=	94
Order No		=	2021.46. 048. 180. 30.94

GUIDE PILLAR WITH COLLAR

2021.28. Guide pillar with collar

d ₁	15 16	19 20	24 25	30 32	38 40	48 50	60 63	80
d ₂	15 16	19 20	24 25	30 32	38 40	48 50	60 63	80
d ₃	22	25	32	40	50	63	80	95
d ₆	33	36	43	51	61	74	91	106
d ₇	45.7	48.7	55.7	63.7	73.7	86.7	103.7	118.7
a	15.9	16.6	18.4	20.4	29.2	33.8	39.8	46.2
a ₁	21.7	23	26	29.5	29.2	33.8	39.8	46.2
m	M8	M8	M8	M8	M8	M8	M8	M12
l ₂	20	23	30	37	37	47	47	60
l ₁								
100	●	●	●					
112	●	●	●	●				
125	●	●	●	●	●			
140	●	●	●	●	●	●		
160	●	●	●	●	●	●	●	
180	●	●	●	●	●	●	●	●
200	●	●	●	●	●	●	●	●
224			●	●	●	●	●	●
250			●	●	●	●	●	●
280				●	●	●	●	●
315				●	●	●	●	●
355					●	●	●	●
400						●	●	●

Ordering Code (example):

Guide pillar with collar	=	2021.28.
Diameter of conduit d ₁	32 mm =	032.
Length l ₁	112 mm =	112
Order No	=	2021.28. 032. 112

GUIDE PILLAR WITH COLLAR ECO-LINE



2021.29.

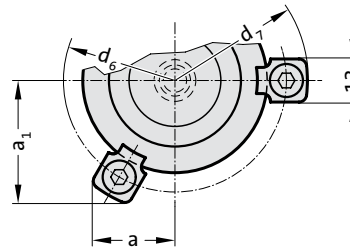
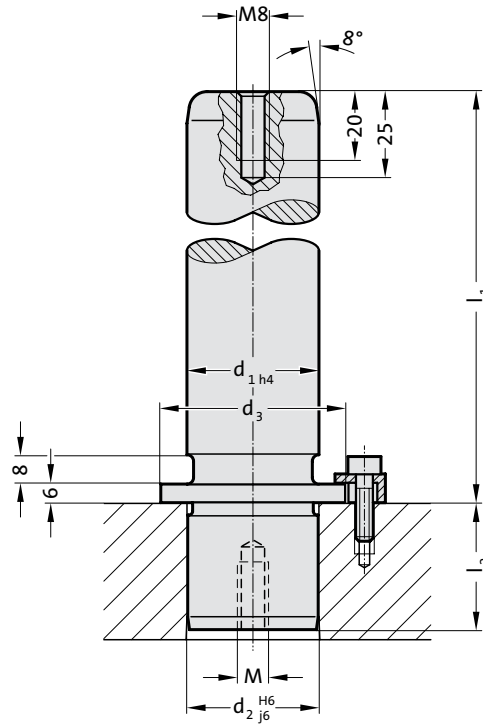

Material:

Steel, surface hardened
 Surface hardness: 60 + 4 HRC, Hardness penetration 1,5 + 1 mm

Execution:

ground
 Method of manufacturing entails that centre holes are not concentric with O.D.

Note:

Guide pillars only recommended for use with sliding guides!
 The attachment is with 3 Screw clamp, from $\varnothing d_1 = 38$ with 4 Screw clamp, which are included in delivery (Order No: 207.45 - Screw clamp incl. socket cap screw DIN 6912, M6x20, Head $\varnothing 13$).
 Optionally, it is also possible to fix it with a central screw connection 2021.43. or supporting ring 2021.45. (order separately).
 ☞ Matching guide combinations, see selection matrix at the beginning of chapter D.
 ☞ Assembly guide lines / Dimensional requirements and tolerances at the end of chapter D.

Mounting example

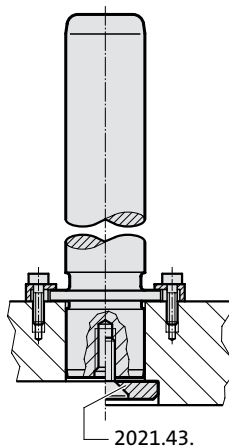

GUIDE PILLAR WITH COLLAR ECO-LINE

2021.29. Guide pillar with collar ECO-LINE

d ₁	15 16	19 20	24 25	30 32	38 40	48 50	60 63	80
d ₂	15 16	19 20	24 25	30 32	38 40	48 50	60 63	80
d ₃	22	25	32	40	50	63	80	95
d ₆	33	36	43	51	61	74	91	106
d ₇	45.7	48.7	55.7	63.7	73.7	86.7	103.7	118.7
a	15.9	16.6	18.4	20.4	29.2	33.8	39.8	46.2
a ₁	21.7	23	26	29.5	29.2	33.8	39.8	46.2
M	M8	M8	M8	M8	M8	M8	M8	M12
l ₂	20	23	30	37	37	47	47	60
l ₁								
100	●	●	●					
112	●	●	●	●				
125	●	●	●	●	●			
140	●	●	●	●	●	●		
160	●	●	●	●	●	●	●	
180	●	●	●	●	●	●	●	
200	●	●	●	●	●	●	●	●
224			●	●	●	●	●	●
250			●	●	●	●	●	●
280				●	●	●	●	●
315				●	●	●	●	●
355					●	●	●	●
400						●	●	●

Ordering Code (example):

Guide pillar with collar ECO-LINE	=	2021.29.
Diameter of conduit d ₁	32 mm =	032.
Length l ₁	112 mm =	112
Order No	=	2021.29. 032. 112

DEMOUNTABLE GUIDE PILLAR WITH CENTRE FIXING

2020.63.

Mounting example

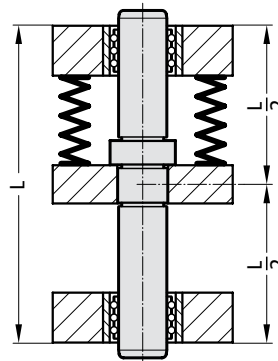
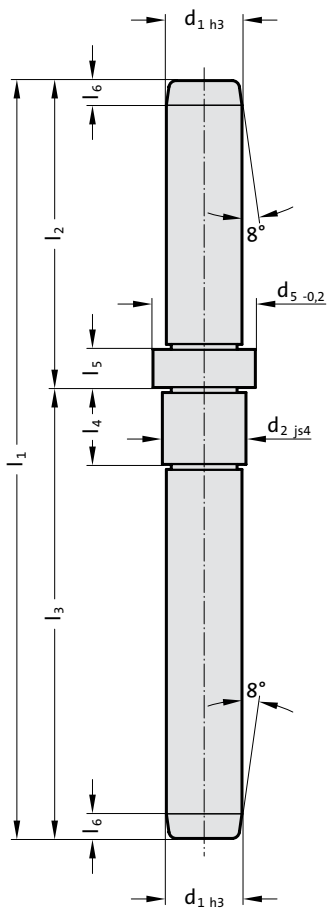

Material:

Steel, surface hardened

Surface hardness: 62 + 2 HRC, Hardness penetration 1 ± 0,2 mm

Execution:

precision ground

Note:

For press fit into register bore N5.

Bending equation see at the beginning of chapter D.

Matching guide combinations, see selection matrix at the beginning of chapter D.

2020.63. Demountable guide pillar with centre fixing

Order No	d ₁	d ₂	d ₅	l ₁	l ₂	l ₃	l ₄	l ₅	l ₆
2020.63.012.042.074	12	13	15.9	116	42	74	12.5	5	3
2020.63.016.064.094	16	18	21.9	158	64	94	16	8	5

DEMOUNTABLE GUIDE PILLAR WITH CENTRE FIXING



2020.62.

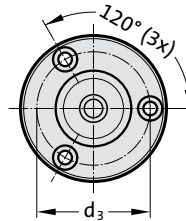
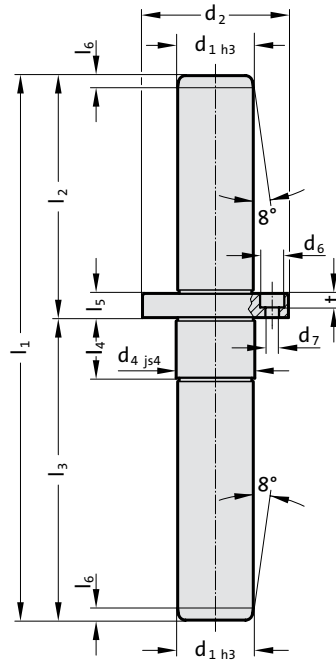

Material:

Steel, (Core strength: $\geq 900 \text{ N/mm}^2$)
 surface hardened
 Surface hardness: $60 + 3 \text{ HRC}$, Hardness
 penetration $2 + 1,6 \text{ mm}$

Execution:

precision ground

Note:

Use socket cap screws DIN EN ISO 4762
 12.9.

 Bearing clearance / Preloading see
 pairing classification at the beginning of
 chapter D.

 Matching guide combinations, see
 selection matrix at the beginning of chapter
 D.

 Bending equation see at the beginning
 of chapter D.

$\varnothing 12$ only available in tolerance range yellow
 = .10

Tolerance range:

yellow = .10

green = .20

red = .30

Mounting example

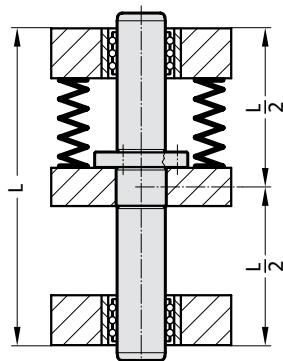

DEMOUNTABLE GUIDE PILLAR WITH CENTRE FIXING

2020.62. Demountable guide pillar with centre fixing

d ₁	d ₂	d ₃	d ₄	d ₆	d ₇	t	l ₁	l ₂	l ₃	l ₄	l ₅	l ₆
12	28	20	13	6	3.4	3.4	90	40	50	12	6	3
12	28	20	13	6	3.4	3.4	100	40	60	12	6	3
12	28	20	13	6	3.4	3.4	110	50	60	12	6	3
12	28	20	13	6	3.4	3.4	120	50	70	12	6	3
12	28	20	13	6	3.4	3.4	130	60	70	12	6	3
12	28	20	13	6	3.4	3.4	140	70	70	12	6	3
16	38	28	18	8	4.5	4.6	140	60	80	16	8	4
16	38	28	18	8	4.5	4.6	150	60	90	16	8	4
16	38	28	18	8	4.5	4.6	160	70	90	16	8	4
16	38	28	18	8	4.5	4.6	170	70	100	16	8	4
16	38	28	18	8	4.5	4.6	180	80	100	16	8	4
16	38	28	18	8	4.5	4.6	190	90	100	16	8	4
19	42	32	22	8	4.5	4.6	160	70	90	20	8	4
19	42	32	22	8	4.5	4.6	170	70	100	20	8	4
19	42	32	22	8	4.5	4.6	180	80	100	20	8	4
19	42	32	22	8	4.5	4.6	190	80	110	20	8	4
19	42	32	22	8	4.5	4.6	200	90	110	20	8	4
19	42	32	22	8	4.5	4.6	210	100	110	20	8	4
25	48	38	26	8	4.5	4.6	180	80	100	22	8	6
25	48	38	26	8	4.5	4.6	190	80	110	22	8	6
25	48	38	26	8	4.5	4.6	200	90	110	22	8	6
25	48	38	26	8	4.5	4.6	210	90	120	22	8	6
25	48	38	26	8	4.5	4.6	220	100	120	22	8	6
25	48	38	26	8	4.5	4.6	230	110	120	22	8	6
32	60	48	34	10	5.5	5.7	180	80	100	25	10	7
32	60	48	34	10	5.5	5.7	190	80	110	25	10	7
32	60	48	34	10	5.5	5.7	200	90	110	25	10	7
32	60	48	34	10	5.5	5.7	210	90	120	25	10	7
32	60	48	34	10	5.5	5.7	220	100	120	25	10	7
32	60	48	34	10	5.5	5.7	230	100	130	25	10	7
32	60	48	34	10	5.5	5.7	240	110	130	25	10	7
32	60	48	34	10	5.5	5.7	250	110	140	25	10	7
40	70	56	42	11	6.6	6.8	200	90	110	27	12	7
40	70	56	42	11	6.6	6.8	210	90	120	27	12	7
40	70	56	42	11	6.6	6.8	220	100	120	27	12	7
40	70	56	42	11	6.6	6.8	230	100	130	27	12	7
40	70	56	42	11	6.6	6.8	240	110	130	27	12	7
40	70	56	42	11	6.6	6.8	250	110	140	27	12	7
40	70	56	42	11	6.6	6.8	260	120	140	27	12	7

Ordering Code (example):

Demountable guide pillar with centre fixing	=	2020.62.
Diameter of conduit d ₁	25 mm =	025.
Length with bush (short) l ₂	80 mm =	080.
Length to bush (long) l ₃	110 mm =	110.
Classification TOL	yellow =	10
Order No	=	2020.62. 025.080. 110. 10

DEMOUNTABLE GUIDE PILLAR WITH CENTRE FIXING AND RING NUT



Mounting example

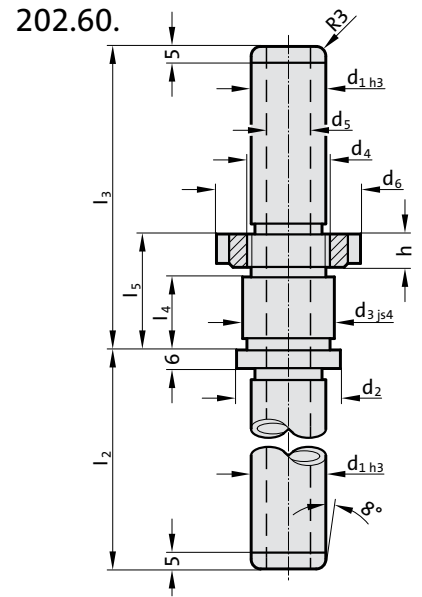
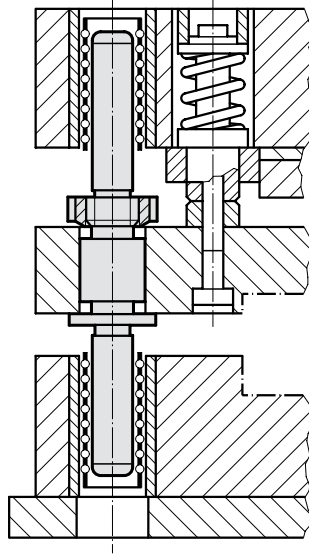



Material:

Steel, (Core strength: $\geq 900 \text{ N/mm}^2$) surface hardened
Surface hardness: $60 + 3 \text{ HRC}$, Hardness penetration $\geq 1,8 \text{ mm}$

Execution:

precision ground

Note:

-  Bearing clearance / Preloading see pairing classification at the beginning of chapter D.
-  Matching guide combinations, see selection matrix at the beginning of chapter D.

 Bending equation see at the beginning of chapter D.

 Assembly guide lines / Dimensional requirements and tolerances at the end of chapter D.

Tolerance range:

yellow = .10

green = .20

red = .30

202.60. Demountable guide pillar with centre fixing and ring nut

d_1	19	25	32	40
d_2	32	38	46	56
d_3	25	30	36	46
d_4	M22x1,5	M28x1,5	M35x1,5	M45x1,5
d_5	8	12	20	28
d_6	40	50	55	68
h	9	10	11	12
l_2	80	80	100	100
l_3	120	120	140	140
l_4	29	29	34	34
l_5	45	45	50	50

Ordering Code (example):

Demountable guide pillar with centre fixing and ring nut	= 202.60.
Diameter of conduit d_1	32 mm = 032.
Length with bush l_2	100 mm = 100.
Length to bush l_3	140 mm = 140.
Classification TOL	yellow = 10
Order No	= 202.60. 032. 100. 140. 10

DEMOUNTABLE GUIDE PILLAR WITH CONICAL CENTRE FIXING

2020.64.

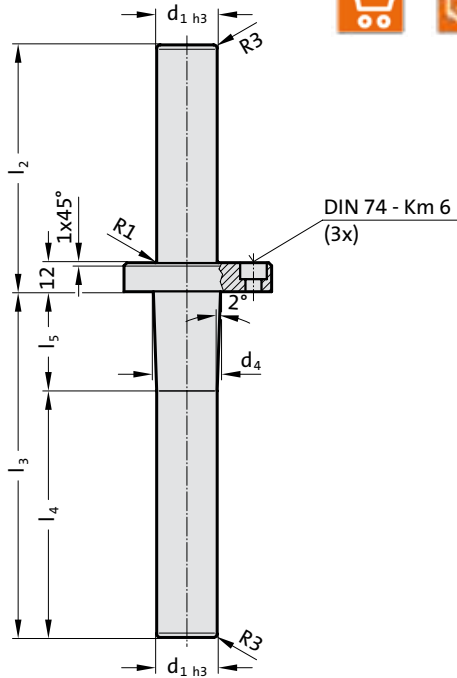

Mounting example

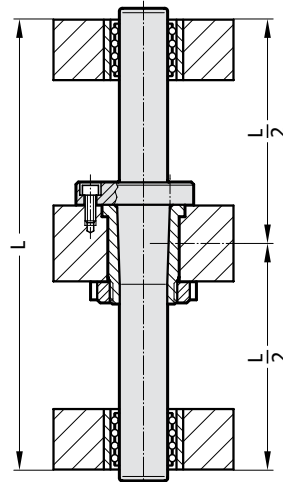

Material:

Steel, hardened 62 ± 2 HRC

Execution:

precision ground

Note:

Matching retaining bush 2021.64.

Use socket cap screws DIN EN ISO 4762 12.9.

Bearing clearance / Preloading see pairing classification at the beginning of chapter D.

Matching guide combinations, see selection matrix at the beginning of chapter D.

Bending equation see at the beginning of chapter D.

Tolerance range:

yellow = .10

green = .20

2020.64. Demountable guide pillar with conical centre fixing

d ₁	25	25	32	32	32	32	32	32
d ₂	70	70	76	76	76	76	76	76
d ₃	55	55	62	62	62	62	62	62
d ₄	27.86	27.86	34.86	34.86	34.86	34.86	34.86	34.86
k	26	26	30	30	30	30	30	30
l ₂	102	122	102	122	122	137	142	162
l ₃	143	143	143	143	153	153	153	153
l ₄	102	102	102	102	112	112	112	112
l ₅	41	41	41	41	41	41	41	41

Ordering Code (example):

Demountable guide pillar with conical centre fixing	= 2020.64.
Diameter of conduit d ₁	32 mm = 032.
Length with bush (short) l ₂	122 mm = 122.
Length to bush (long) l ₃	153 mm = 153.
Classification TOL	yellow = 10
Order No	= 2020.64. 032.122.153.10