

## **GAS SPRINGS SPC - SPEED CONTROL™**

### **Description:**

FIBRO SPC - SPEED CONTROL™ gas springs have been engineered to reduce or eliminate blank holder bounce; commonly associated with increased return stroke speeds from link drive presses.

The SPC gas springs have an integrated return stroke delay, which reduces the speed of the gas spring to 0.4 m/s during the last 30 mm stroke. This gently stops the sheet holder.

### **Properties:**

- prevents the blank holder springing back
- Productivity increase due to more efficient parts transport
- Easy to install in existing tools
- Stroke lengths of 125 to 300 mm
- can be connected to existing hose system

## GAS SPRINGS SPC - SPEED CONTROL™

### Performance:

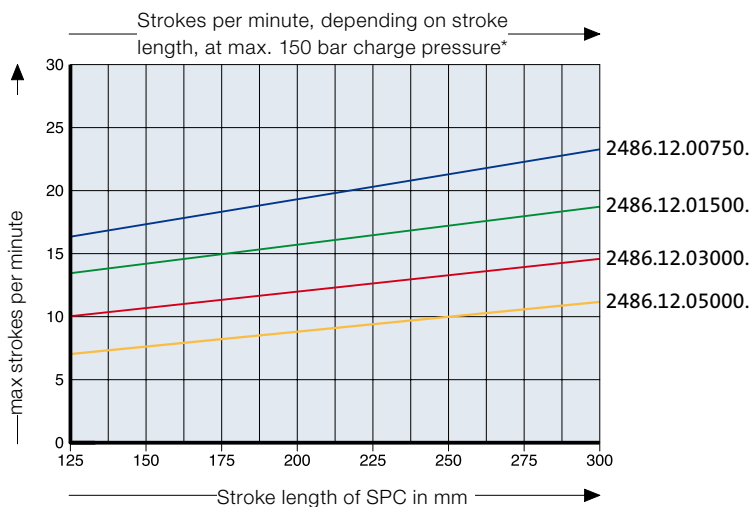

The diagram shows the max. possible number of strokes per minutes [min<sup>-1</sup>] of SPC gas springs with a max. filling pressure (150 bar) and max. used stroke lengths before there is a risk of excessive heating.



#### Note !

The number of strokes per minutes can be doubled by halving the initial filling pressure.



#### Caution !

SPC gas springs are subject to a higher heating than standard gas springs. For this reason, please ensure adequate ventilation of the SPC gas springs in the tool.

\*At ambient room temperature with free air flow

### Function example:

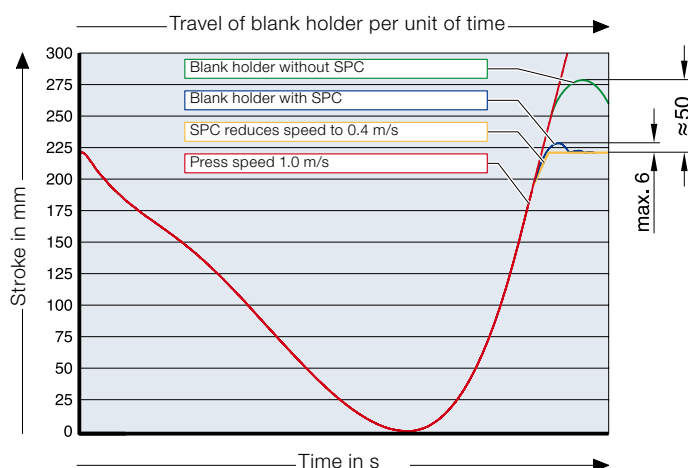

**SPC - SPEED CONTROL™ gas springs gave a 90% reduction of blank holder bounce.**

### Installation:

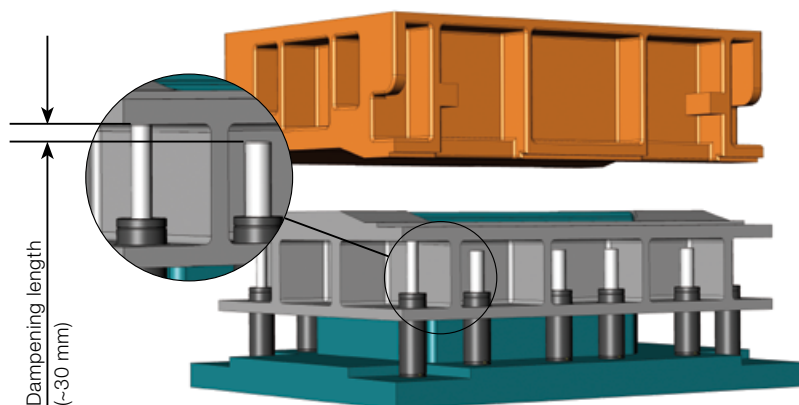

It is important that approx. 25 to 30 mm before the sheet metal retainer has reached its home position, only SPC gas springs are applied. Therefore, for the retrofitting of existing tools with SPC gas springs we recommend the following two options:

#### Option 1:

Replace all existing gas springs holding the blank holder with SPC gas springs

#### Option 2:

SPC gas springs with a min. 25 mm longer nominal stroke length than with the "main gas pressure springs" are positioned at the four corners of the blank holder. This lifts the blank holder from the "main gas pressure springs".

#### Attention:

Springs must be installed with a recess of 25 mm to balance the total length difference (2 x stroke length = 50 mm). Alternatively, the contact surface of the sheet metal retainer can be recessed in order to achieve the same effect.

# GAS SPRING SPEED CONTROL, CUSHIONED MOUNTING VARIATIONS

2480.007.01500

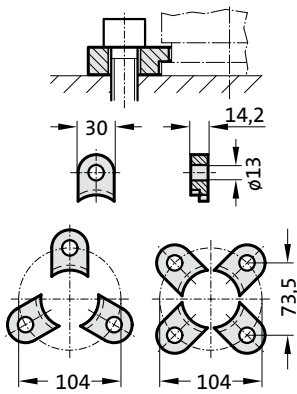

2480.008.01500<sup>3)</sup>

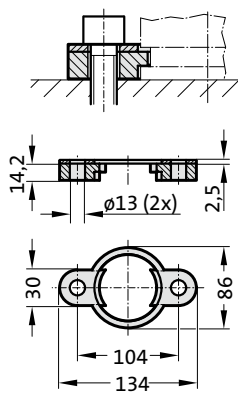

2480.011.01500

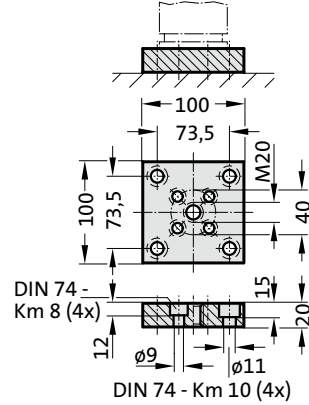

2480.011.01500.2

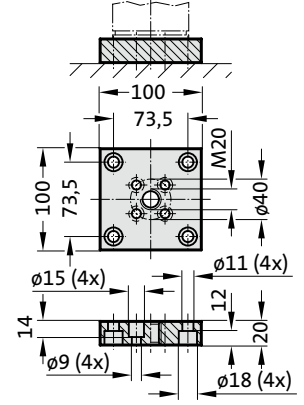

2480.022.01500

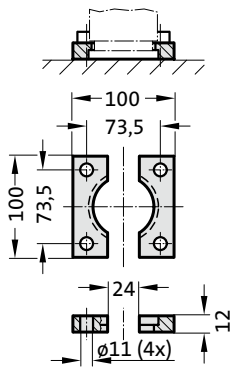

2480.044.01500<sup>2)</sup>

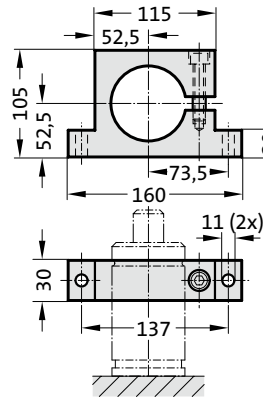

2480.044.03.01500<sup>2)</sup>

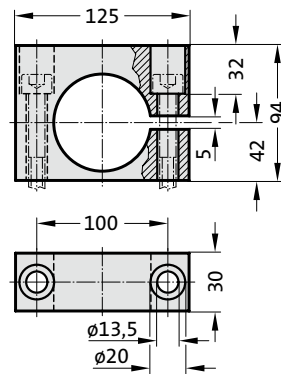

2480.045.01500<sup>2)</sup>

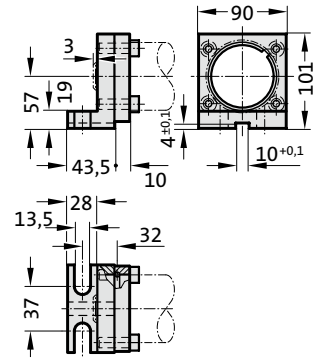

2480.047.01500<sup>2)</sup>

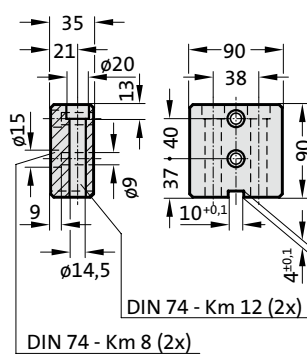

2480.055.01500

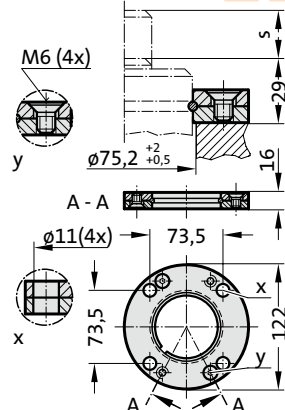

2480.057.01500

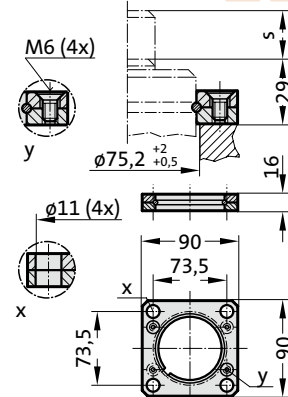

2480.064.01500<sup>4)</sup>

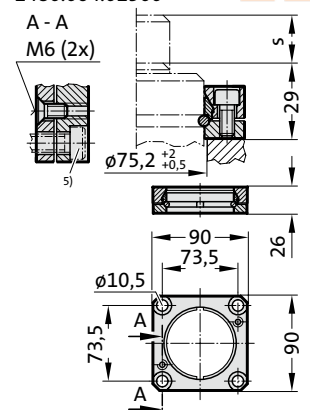

## Note:

- <sup>2)</sup> Attention:  
The spring force must be absorbed by the stop Surface!
- <sup>3)</sup> Not for use with composite connection.
- <sup>4)</sup> Square collar flange, non-rotating, fixing for composite connection.
- <sup>5)</sup> Machine screws with hexagonal socket (compact head recommended)

# GAS SPRING SPEED CONTROL, CUSHIONED

**Note:**

Initial spring force at 150 bar = 750 daN

Order No for spare parts kit: 2486.12.00750

Pressure medium: Nitrogen N<sub>2</sub>  
 Max. filling pressure: 150 bar  
 Min. filling pressure: 25 bar  
 Working temperature: 0°C to +80°C  
 Temperature related force increase: ± 0.3%/°C  
 Max. recommended extensions per minute: approx. 16 to 24 (at 20°C)  
 Dampening length: ~ 30 mm  
 Piston rod speed, decelerated: 0.4 m/s

2486.12.00750.

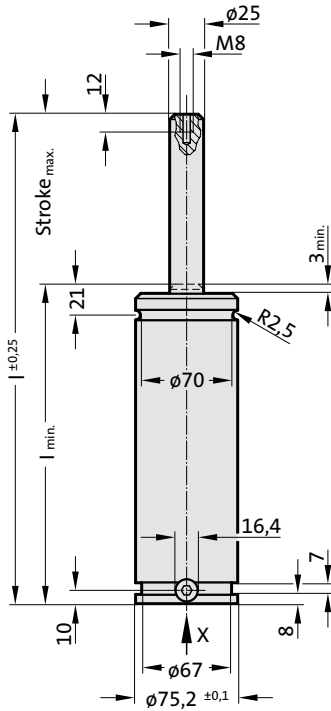

View X - Gas spring

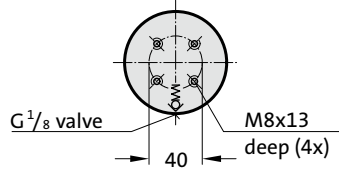

2486.12.00750.

**Gas spring SPEED CONTROL, cushioned**

Order No	Stroke <sub>max.</sub> (s)	l <sub>min.</sub>	l
2486.12.00750.125	125	235	360
2486.12.00750.160	160	270	430
2486.12.00750.200	200	310	510
2486.12.00750.250	250	360	610
2486.12.00750.300	300	410	710

Initial spring force versus charge pressure

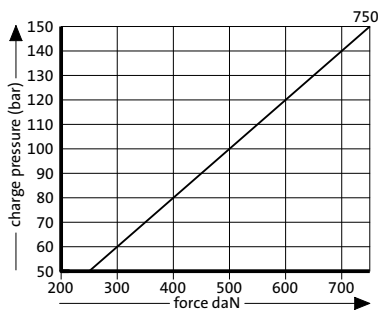

Spring force Diagram displacement versus stroke rise

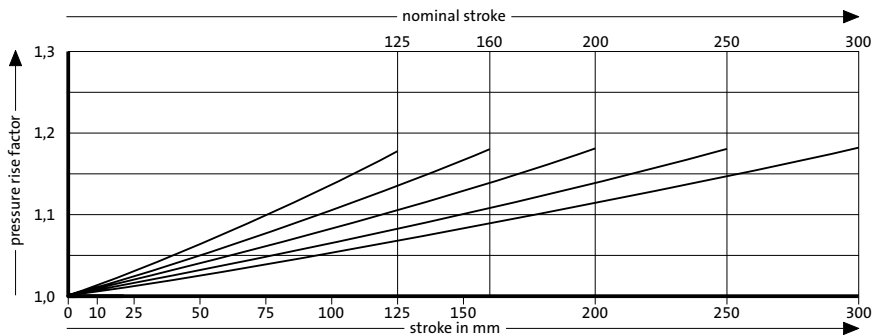

Pressure rise factor accounts for displacement but not external influences!

# GAS SPRING SPEED CONTROL, CUSHIONED MOUNTING VARIATIONS

2480.007.03000

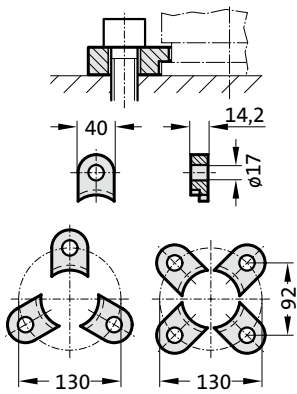

2480.008.03000<sup>3)</sup>

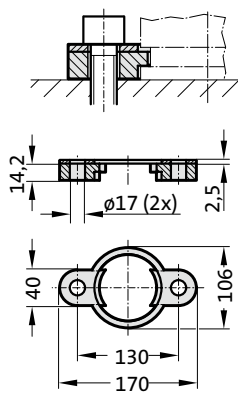

2480.011.03000

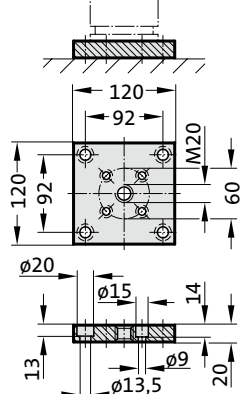

2480.011.03000.2

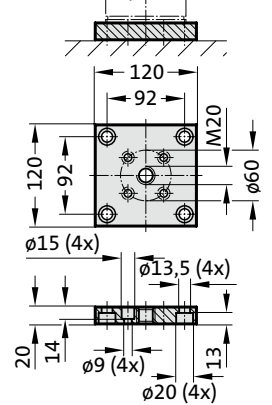

2480.022.03000

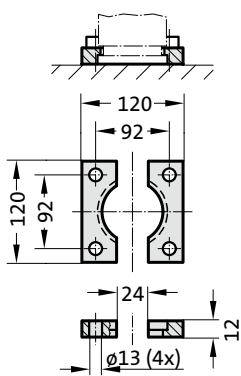

2480.044.03000<sup>2)</sup>

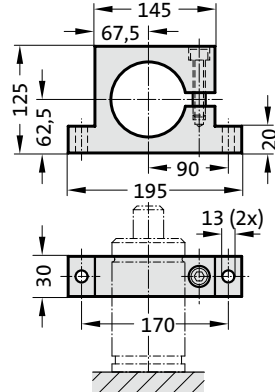

2480.044.03.03000<sup>2)</sup>

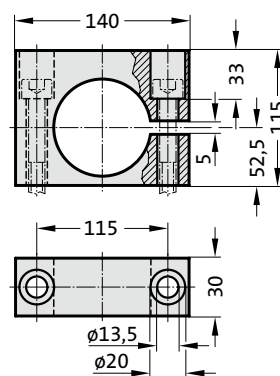

2480.045.03000<sup>2)</sup>

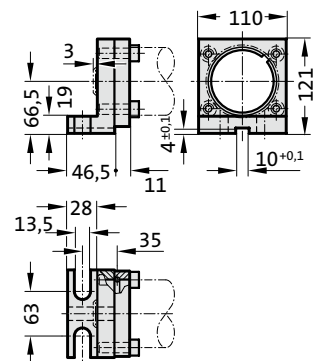

2480.047.03000<sup>2)</sup>

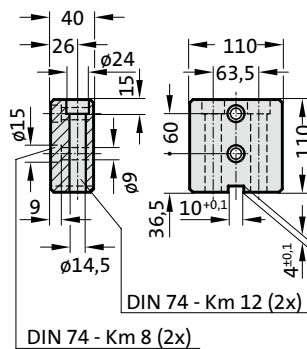

2480.055.03000

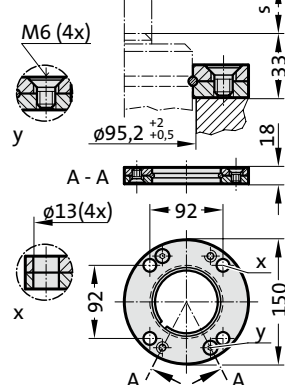

2480.057.03000

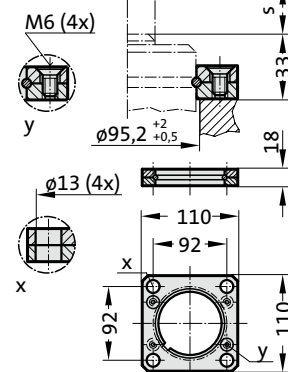

2480.064.03000<sup>4)</sup>

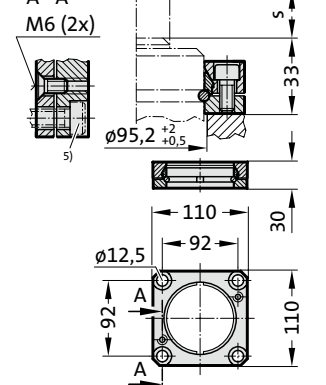

## Note:

- <sup>2)</sup> Attention:  
The spring force must be absorbed by the stop Surface!
- <sup>3)</sup> Not for use with composite connection.
- <sup>4)</sup> Square collar flange, non-rotating, fixing for composite connection.
- <sup>5)</sup> Machine screws with hexagonal socket (compact head recommended)

# GAS SPRING SPEED CONTROL, CUSHIONED

**Note:**

Initial spring force at 150 bar = 1500 daN

Order No for spare parts kit: 2486.12.01500

- Pressure medium: Nitrogen N<sub>2</sub>
- Max. filling pressure: 150 bar
- Min. filling pressure: 25 bar
- Working temperature: 0°C to +80°C
- Temperature related force increase: ± 0.3%/°C
- Max. recommended extensions per minute: approx. 14 to 19 (at 20°C)
- Dampening length: ~ 30 mm
- Piston rod speed, decelerated: 0.4 m/s

2486.12.01500.

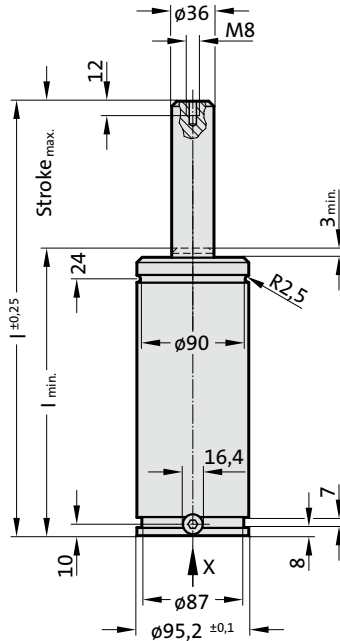

View X - Gas spring

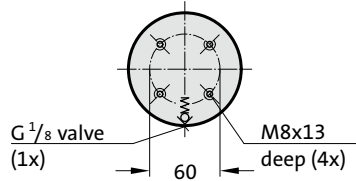

2486.12.01500.

**Gas spring SPEED CONTROL, cushioned**

Order No	Stroke <sub>max.</sub> (s)	I <sub>min.</sub>	I
2486.12.01500.125	125	245	370
2486.12.01500.160	160	280	440
2486.12.01500.200	200	320	520
2486.12.01500.250	250	370	620
2486.12.01500.300	300	420	720

Initial spring force versus charge pressure

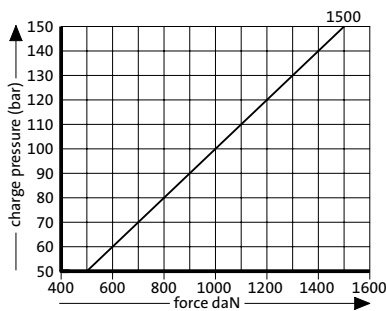

Spring force Diagram displacement versus stroke rise

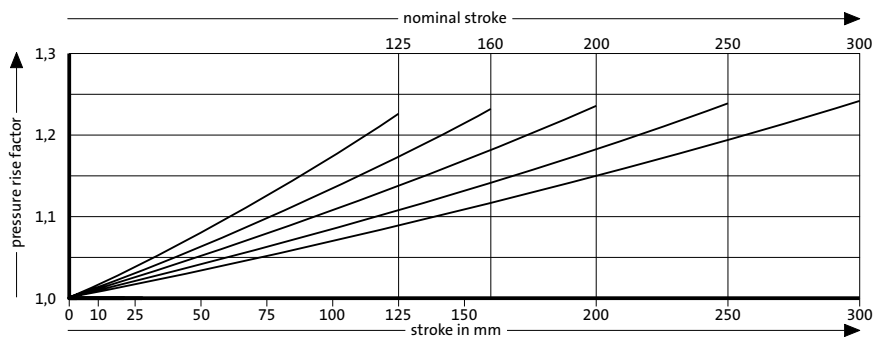

Pressure rise factor accounts for displacement but not external influences!

# GAS SPRING SPEED CONTROL, CUSHIONED MOUNTING VARIATIONS

2480.007.05000

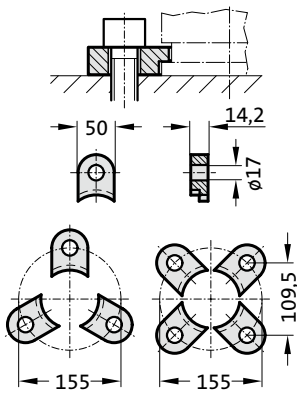

2480.008.05000<sup>3)</sup>

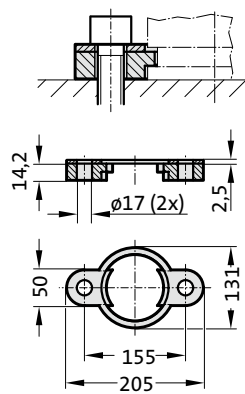

2480.011.05000

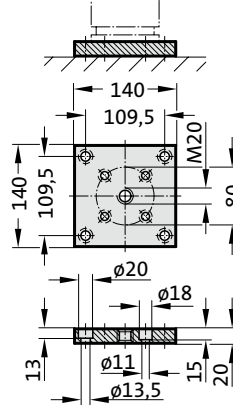

2480.011.05000.2

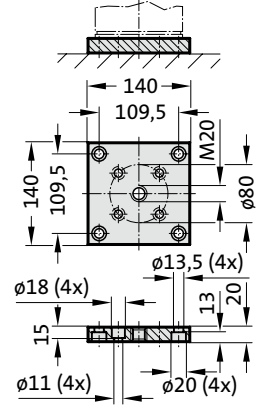

2480.022.05000

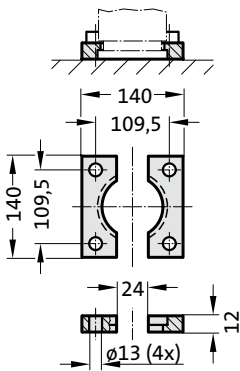

2480.044.05000<sup>2)</sup>

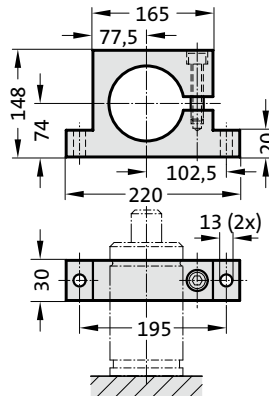

2480.044.03.05000<sup>2)</sup>

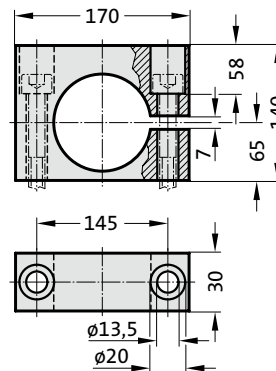

2480.045.05000<sup>2)</sup>

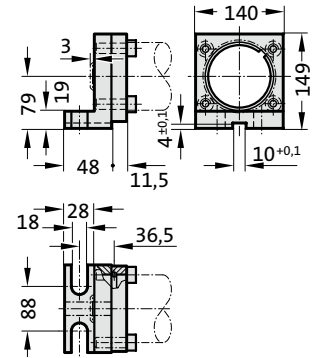

2480.047.05000<sup>2)</sup>

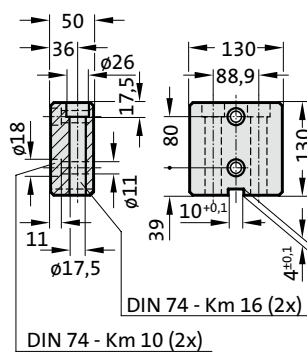

2480.055.05000

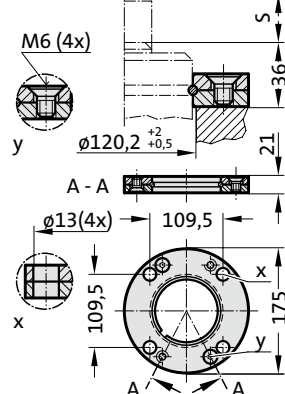

2480.057.05000

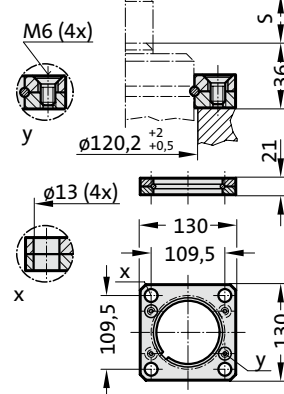

2480.064.05000<sup>4)</sup>

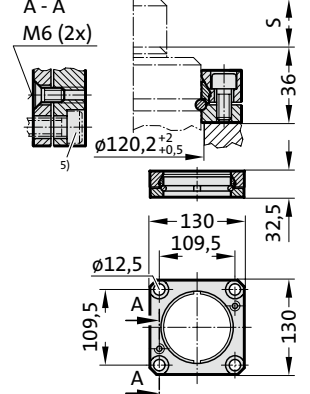

## Note:

- <sup>2)</sup> Attention:  
The spring force must be absorbed by the stop Surface!
- <sup>3)</sup> Not for use with composite connection.
- <sup>4)</sup> Square collar flange, non-rotating, fixing for composite connection.
- <sup>5)</sup> Machine screws with hexagonal socket (compact head recommended)

# GAS SPRING SPEED CONTROL, CUSHIONED

**Note:**

Initial spring force at 150 bar = 3000 daN

Order No for spare parts kit: 2486.12.03000

- Pressure medium: Nitrogen N<sub>2</sub>
- Max. filling pressure: 150 bar
- Min. filling pressure: 25 bar
- Working temperature: 0°C to +80°C
- Temperature related force increase: ± 0.3%/°C
- Max. recommended extensions per minute: approx. 10 to 13 (at 20°C)
- Dampening length: ~ 30 mm
- Piston rod speed, decelerated: 0.4 m/s

2486.12.03000.

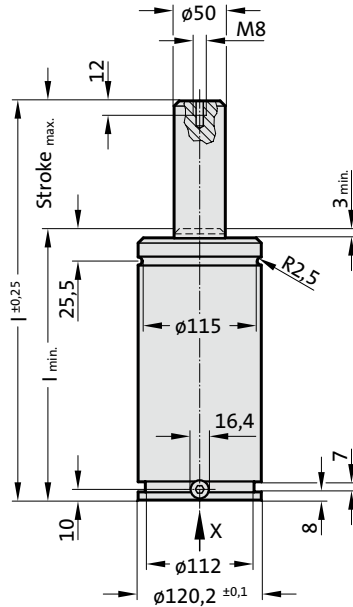

View X - Gas spring

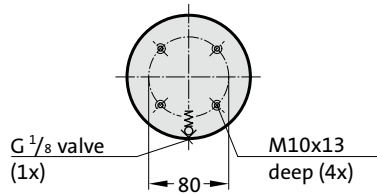

2486.12.03000.

**Gas spring SPEED CONTROL, cushioned**

Order No	Stroke <sub>max.</sub> (s)	l <sub>min.</sub>	l
2486.12.03000.125	125	265	390
2486.12.03000.160	160	300	460
2486.12.03000.200	200	340	540
2486.12.03000.250	250	390	640
2486.12.03000.300	300	440	740

Initial spring force versus charge pressure

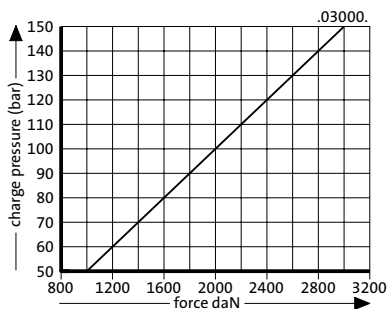

Spring force Diagram displacement versus stroke rise

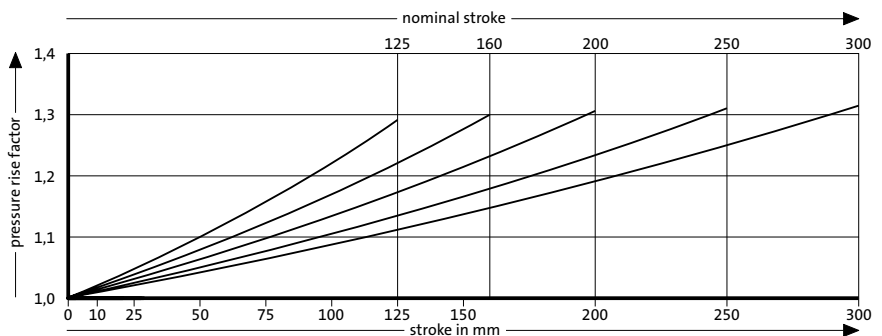

Pressure rise factor accounts for displacement but not external influences!



# GAS SPRING SPEED CONTROL, CUSHIONED MOUNTING VARIATIONS

2480.007.07500

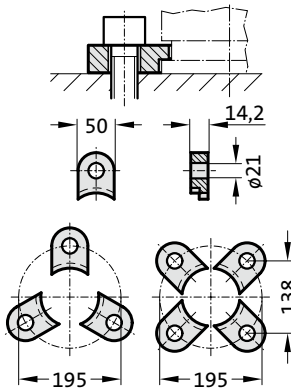

2480.008.07500<sup>3)</sup>

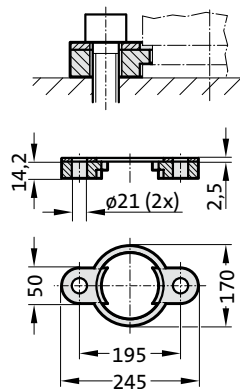

2480.011.07500

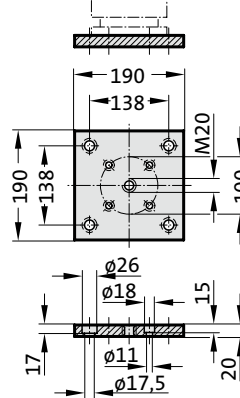

2480.011.07500.2

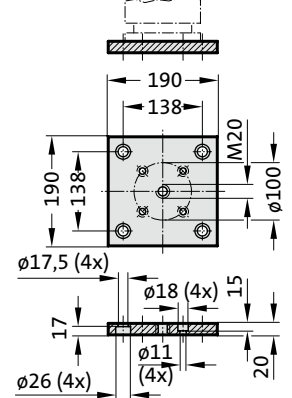

2480.011.03.07500

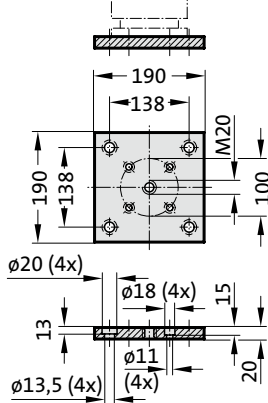

2480.011.03.07500.2

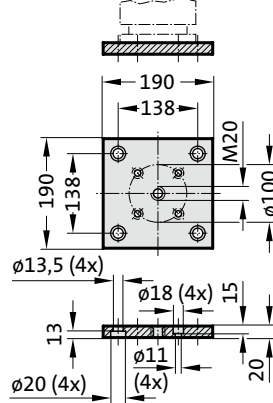

2480.022.07500

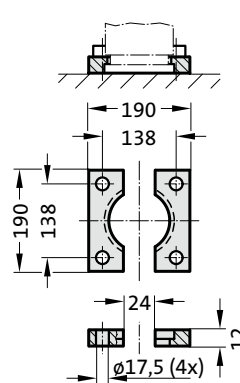

2480.044.07500<sup>2)</sup>

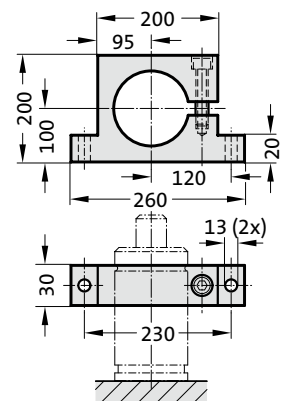

2480.044.03.07500<sup>2)</sup>

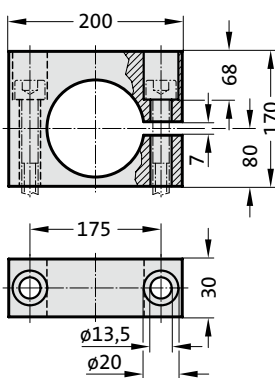

2480.055.07500

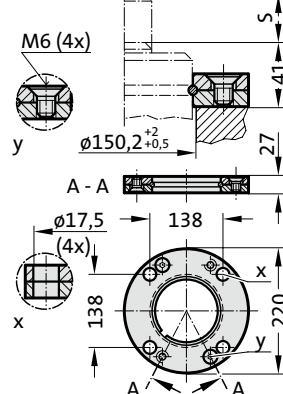

2480.057.07500

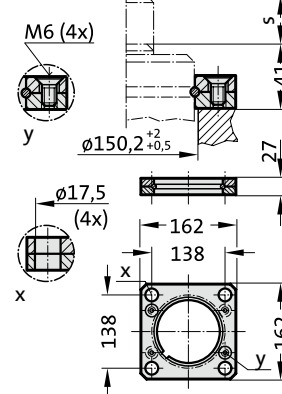

2480.064.07500<sup>4)</sup>

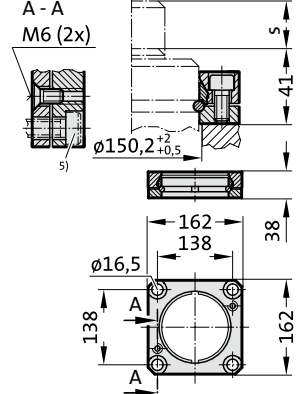

## Note:

- <sup>2)</sup> Attention:  
The spring force must be absorbed by the stop Surface!
- <sup>3)</sup> Not for use with composite connection.
- <sup>4)</sup> Square collar flange, non-rotating, fixing for composite connection.
- <sup>5)</sup> Machine screws with hexagonal socket (compact head recommended)

# GAS SPRING SPEED CONTROL, CUSHIONED

**Note:**

Initial spring force at 150 bar = 5000 daN

Order No for spare parts kit: 2486.12.05000

- Pressure medium: Nitrogen N<sub>2</sub>
- Max. filling pressure: 150 bar
- Min. filling pressure: 25 bar
- Working temperature: 0°C to +80°C
- Temperature related force increase: ± 0.3%/°C
- Max. recommended extensions per minute: approx. 6 to 11 (at 20°C)
- Dampening length: ~ 30 mm
- Piston rod speed, decelerated: 0.4 m/s

2486.12.05000.

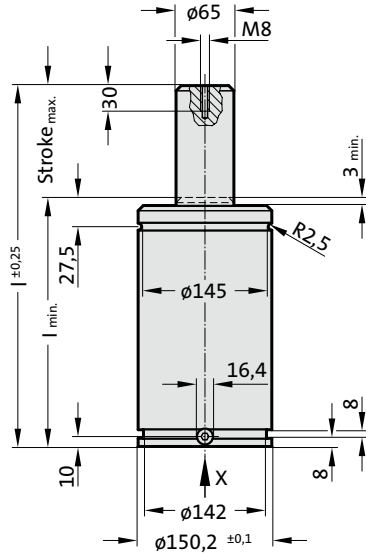

View X - Gas spring

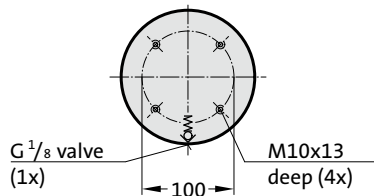

2486.12.05000.

**Gas spring SPEED CONTROL, cushioned**

Order No	Stroke <sub>max.</sub> (s)	l <sub>min.</sub>	l
2486.12.05000.125	125	280	405
2486.12.05000.160	160	315	475
2486.12.05000.200	200	355	555
2486.12.05000.250	250	405	655
2486.12.05000.300	300	455	755

Initial spring force versus charge pressure

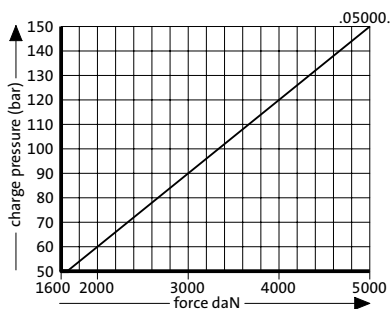

Spring force Diagram displacement versus stroke rise

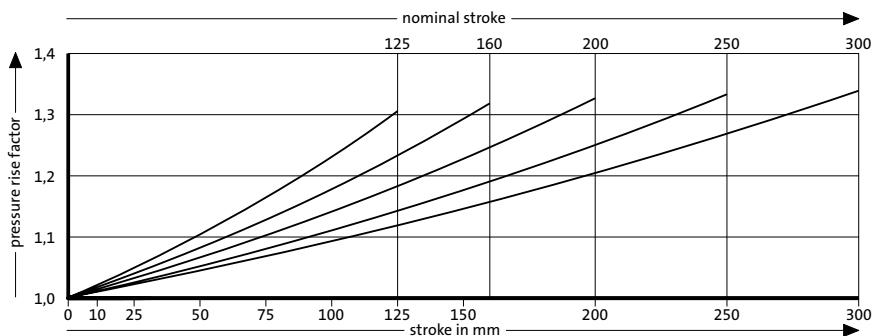

Pressure rise factor accounts for displacement but not external influences!